

## **PROJECT STATEMENT**

### **Property Information:**

#### **Penrose Library**

Parcel Address: 20 N CASCADE AVE

Parcel Number: 6418213002, 6418213007, 6418213008, 6418213013

Zoning: FBZ-CEN

Acreage: 2.93

Legal Description: LOTS 9 TO 13 INC, LOT 14 EX PART TO ST BLK A ADD 5 COLO SPGS

### **Project seeks relief from the following review criteria of the Form Based Code (FBC):**

#### *2.4.1 Common Lawn*

*A landscaped frontage wherein the façade is set back from the property line (but minimum and maximum setbacks are met). The front yard remains unfenced and is visually continuous with adjacent yards supporting a common landscape.*

### **Current Conditions driving the request:**

The Pikes Peak Library District is proposing much-needed fencing improvements at the downtown Colorado Springs Penrose Branch Campus to address ongoing issues with vandalism and unauthorized after-hours activities. The upkeep required due to regular after-hours camping and vandalism has become increasingly costly and time-consuming for the district.

The Penrose Campus is a significant site that includes the Penrose Library, the historic Carnegie Library, the Knights of Columbus Hall, and the historic Antlers Parking Garage Façade. To enhance security while respecting the architectural integrity of these historic buildings, two distinct types of fencing are being proposed around the campus perimeter.

### **Measures that the Library District has taken:**

The library has already hired additional Security Officers and expanded the arrival and departure times of these officers at the Penrose campus. Our facilities team checks the campus and adjacent city sidewalk and gutters each morning to clean up human feces, garbage and drug paraphernalia before opening. PPLD provides exterior garbage cans on our property adjacent to city right of ways that we empty as full to encourage proper disposal of refuse. Security has installed additional cameras around all of the exterior of the downtown campus with improved resolution and notification features. The library continues to work closely with CSPD to implement any recommendations they have and encourage response for identified issues.

**Proposed Modifications:**

An 8-foot-tall wrought iron fence is suggested for the areas surrounding the historic buildings on the campus. This style of fencing is already in place between the Carnegie Library and the Knights of Columbus Hall, blending seamlessly with the existing structures. This style will also be used around the lower parking lot. Vehicular wrought iron gates are proposed at the entrances in to the lower parking lot, and the style is consistent with the historic Antlers Parking Garage Façade.

The second type of fencing proposed is a modern security fence made of thick gauge welded wire. This see-through design is non-obstructive, ensuring an open feel while effectively restricting trespassing. This style will be used around the more modern buildings on campus. Sliding gates with this fence style are proposed at the vehicular access to the upper parking lot, and at the main pedestrian entrance.

Given that the library is a public institution, it is crucial that it remains open and inviting during the day, particularly at the main entrance and plaza space. To maintain this welcoming atmosphere, a large sliding gate is planned. When open, this gate will be hidden behind a proposed corten steel wall, which stands approximately 8 feet tall. This wall will complement the existing architecture and provide additional opportunities for library signage or art installations.

These fencing improvements are essential for protecting the campus while maintaining its open, inviting nature during operational hours, ensuring that the Penrose Library Campus remains a safe and welcoming space for the community.

Attachments:



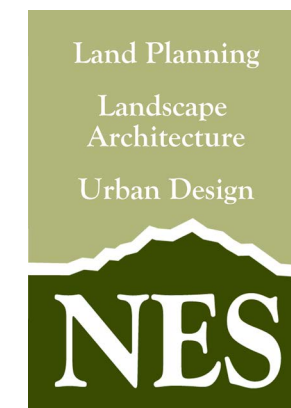

# Pikes Peak Library District

## - Penrose Campus Fencing Improvements

08/13/2024

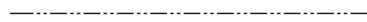

# Plan View

-  Property Line
-  8' HT. Omega 2Secur Fence
-  8' HT. Corten steel wall
-  8' HT. Wrought Iron Fence

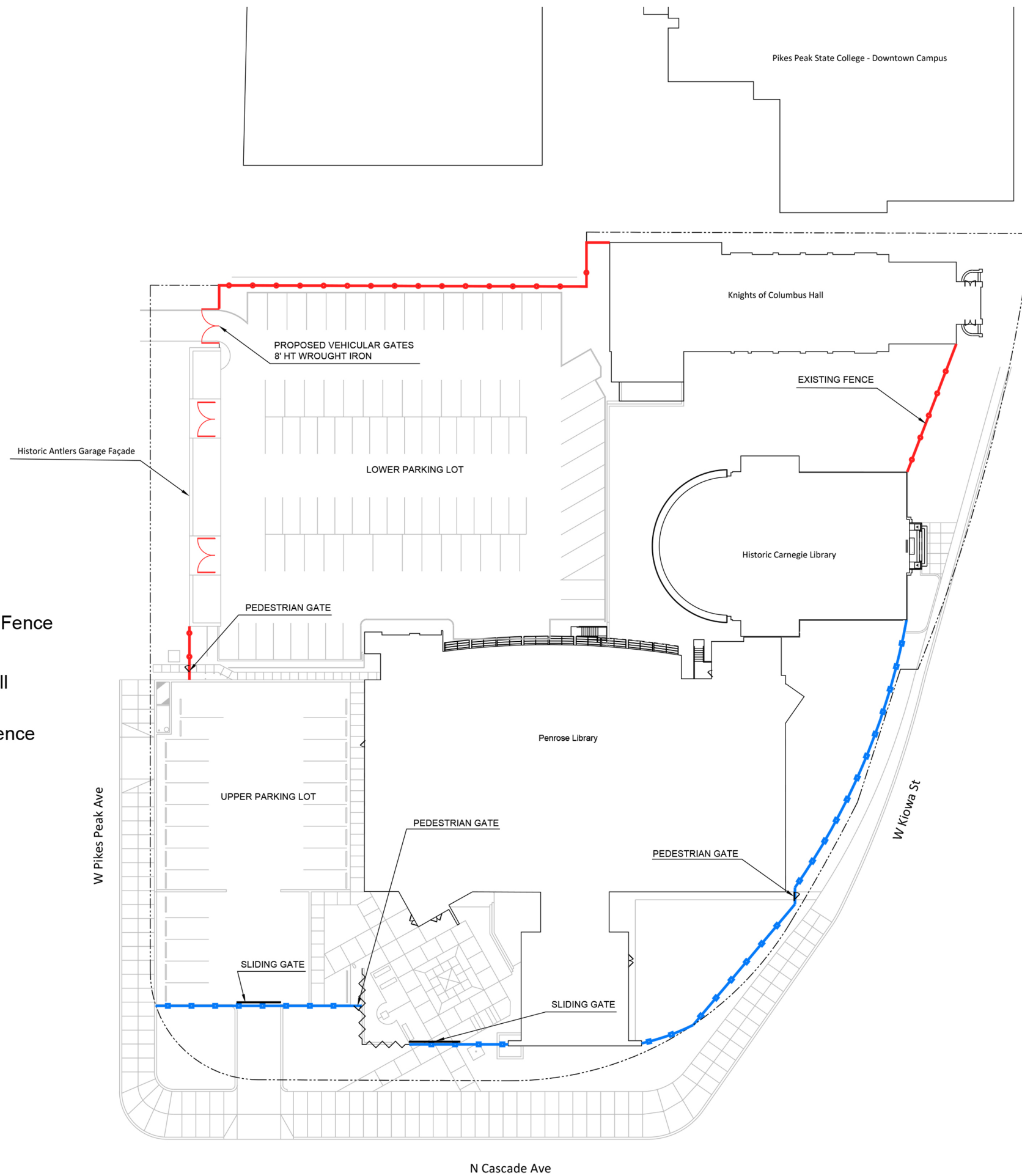
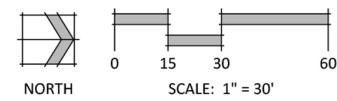







PIKES PEAK LIBRARY DISTRICT  
ppd













# Fencing options

# Option one and two: Secur (Double Wire)

8' PANEL (65 lb/29.5 kg)

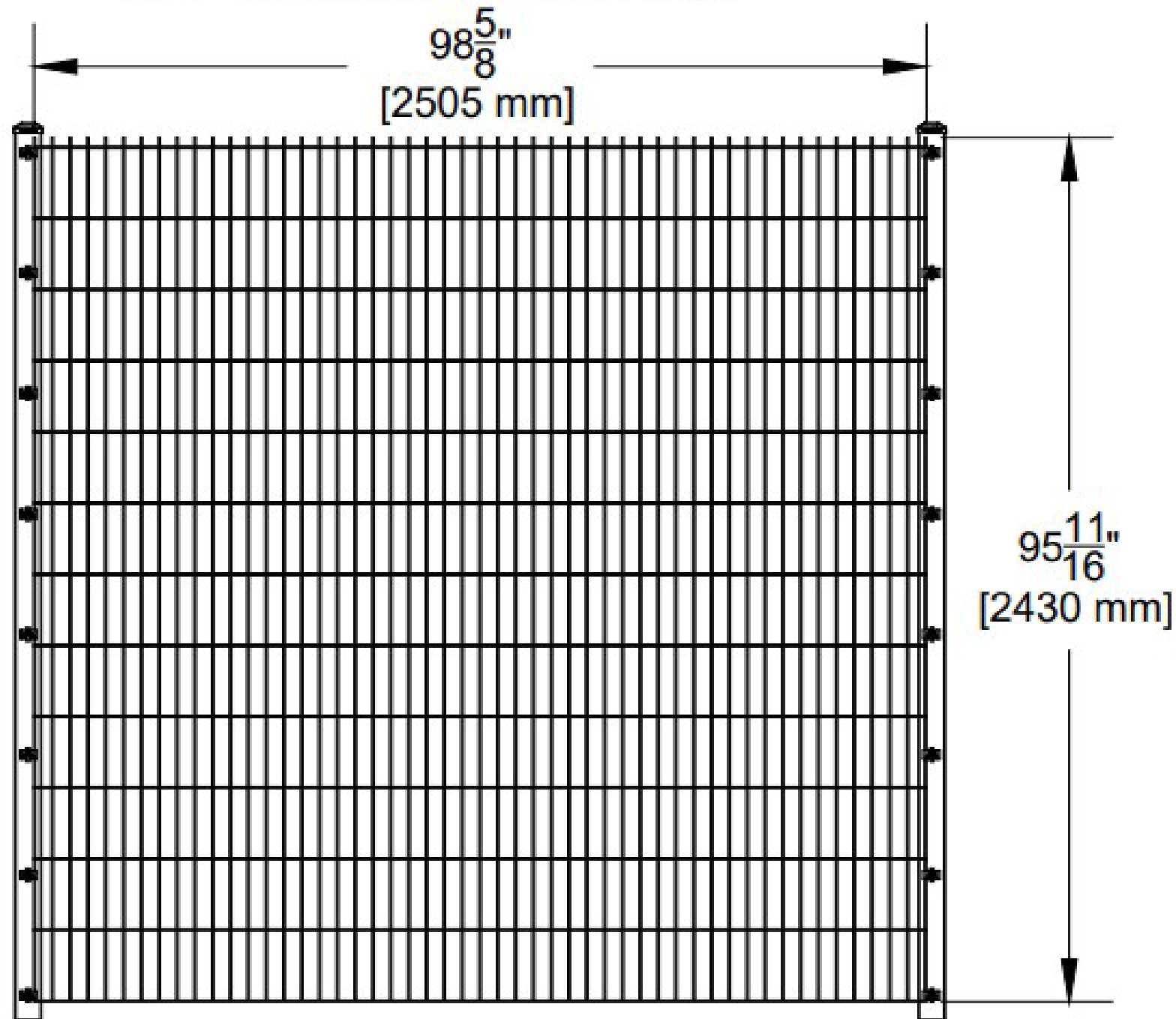

## Secur (Double Wire)

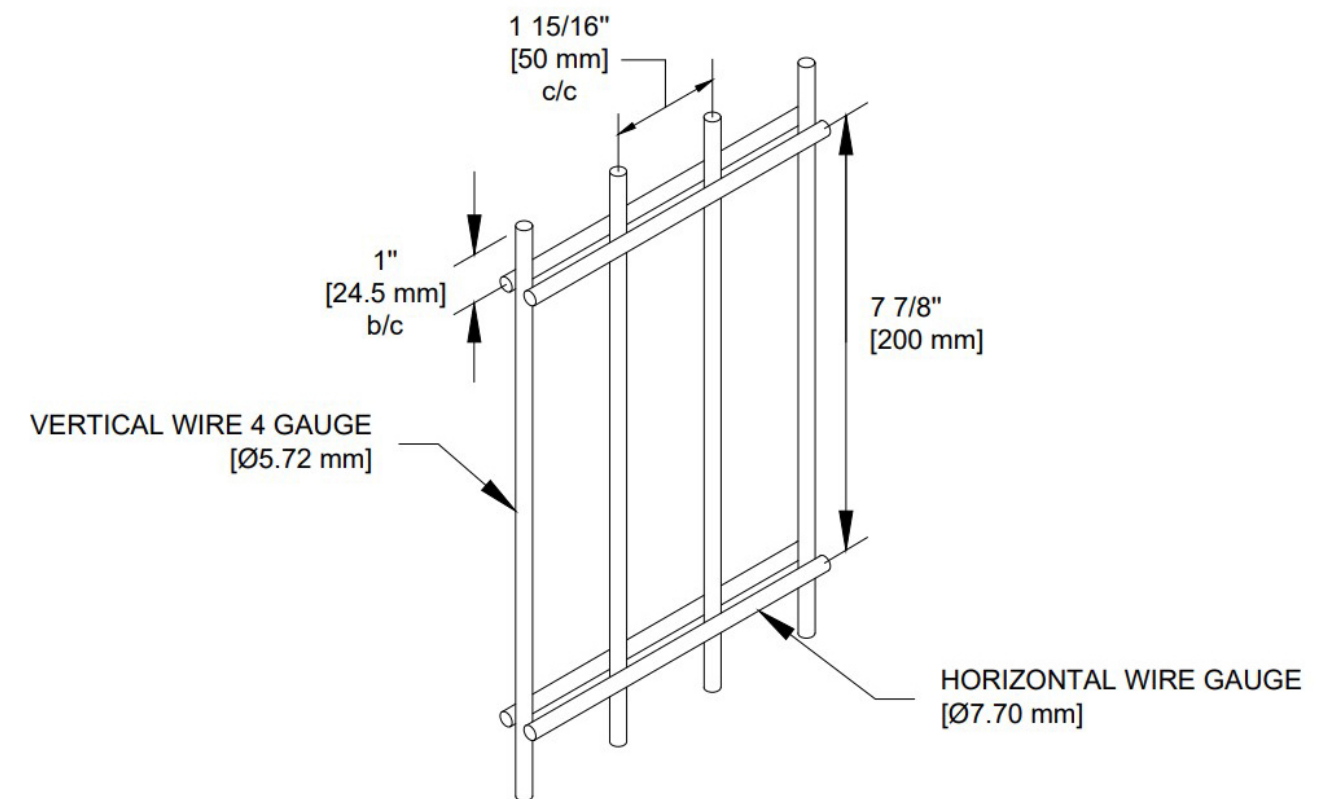

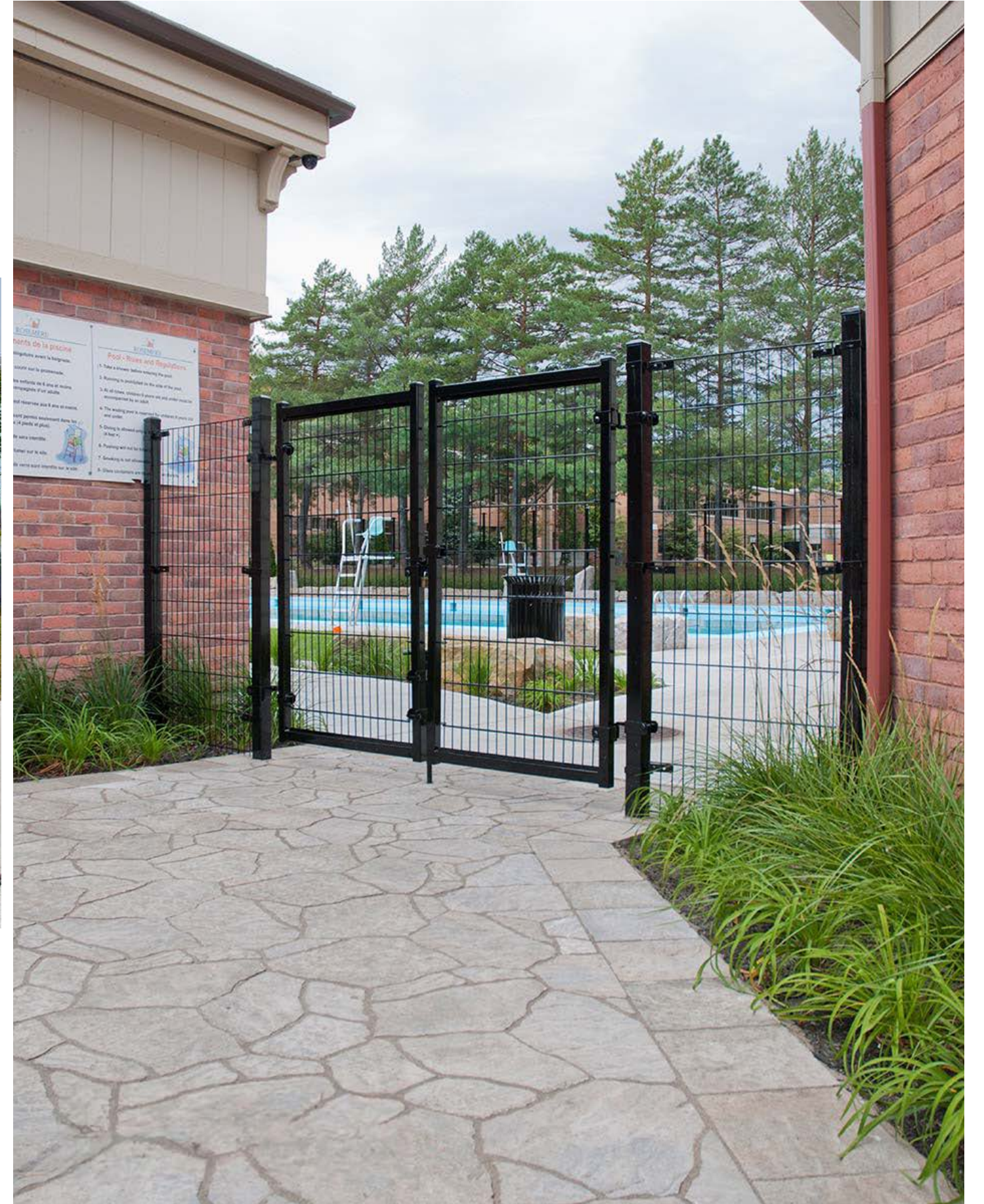

# Existing Wrought Iron Fence

