

Traffic Impact Study

Ovation

Colorado Spring, Colorado

Prepared for:

La Plata Communities, Inc.

Kimley»Horn

T R A F F I C I M P A C T S T U D Y

Ovation

Colorado Springs, Colorado

Prepared for
La Plata Communities, Inc.
9540 Federal Drive
Suite 200
Colorado Springs, Colorado 80921

Prepared by
Kimley-Horn and Associates, Inc.
2 North Nevada Avenue
9th Floor
Colorado Springs, Colorado 80903
(719) 453-0180



September 2023

This document, together with the concepts and designs presented herein, as an instrument of service, is intended only for the specific purpose and client for which it was prepared. Reuse of and improper reliance on this document without written authorization and adaptation by Kimley-Horn and Associates, Inc. shall be without liability to Kimley-Horn and Associates, Inc.

TABLE OF CONTENTS

TABLE OF CONTENTS	i
LIST OF TABLES	ii
LIST OF FIGURES	ii
1.0 EXECUTIVE SUMMARY	1
2.0 INTRODUCTION	4
3.0 EXISTING AND FUTURE CONDITIONS	6
3.1 Existing Study Area	6
3.2 Existing Roadway Network	6
3.3 Existing Traffic Volumes	13
3.4 Unspecified Development Traffic Growth	13
4.0 PROJECT TRAFFIC CHARACTERISTICS	17
4.1 Trip Generation	17
4.2 Trip Distribution	17
4.3 Traffic Assignment	19
4.4 Total (Background Plus Project) Traffic	19
5.0 TRAFFIC OPERATIONS ANALYSIS	23
5.1 Analysis Methodology	23
5.2 Key Intersection Operational Analysis	24
5.3 CDOT Turn Bay Length Analysis	32
5.4 Vehicle Queuing Analysis	32
5.5 Improvement Summary	33
6.0 CONCLUSIONS AND RECOMMENDATIONS	36

APPENDICES

- Appendix A – Intersection Count Sheets
- Appendix B – Future Traffic Projections
- Appendix C – Trip Generation Worksheets
- Appendix D – Intersection Analysis Worksheets
- Appendix E – Signal Timings Worksheets
- Appendix F – Signal Warrant Analysis Worksheets
- Appendix G – Queue Analysis Worksheets

LIST OF TABLES

Table 1 – Ovation Traffic Generation	17
Table 2 – Level of Service Definitions	23
Table 3 – Old Ranch Road & Voyager Parkway (#1) LOS Results.....	25
Table 4 – Old Ranch Road & Lexington Drive (#2) LOS Results.....	27
Table 5 – Old Ranch Road & Chapel Ridge Drive (#3) LOS Results.....	28
Table 6 – Old Ranch Road & Powers Boulevard Southbound Ramp (#4) LOS Results	29
Table 7 – Old Ranch Road & Powers Boulevard Northbound Ramp (#5) LOS Results.....	30
Table 8 – Project Access Level of Service Results.....	31
Table 9 – Turn Lane Queuing Analysis Results.....	32

LIST OF FIGURES

Figure 1 – Vicinity Map.....	5
Figure 2 – Existing Geometry and Control.....	12
Figure 3 – 2023 Existing Traffic Volumes.....	14
Figure 4 – 2025 Background Traffic Volumes.....	15
Figure 5 – 2045 Background Traffic Volumes.....	16
Figure 6 – Project Trip Distribution.....	18
Figure 7 – Project Traffic Assignment	20
Figure 8 – 2025 Total Traffic Volumes	21
Figure 9 – 2045 Total Traffic Volumes	22
Figure 10 – 2025 Recommended Geometry and Control	34
Figure 11 – 2045 Recommended Geometry and Control	35

1.0 EXECUTIVE SUMMARY

This report has been prepared to document the results of a Traffic Impact Study for the Ovation residential project proposed to be located along Chapel Ridge Drive between Powers Boulevard (SH-21) and Old Ranch Road in Colorado Springs, Colorado. The Ovation property is shown to include a maximum of 360 single-family homes. It is expected that Ovation will be completed in the next few years; therefore, analysis was conducted for the 2025 short-term buildout horizon as well as the 2045 long-term twenty-year planning horizon.

The purpose of this traffic study is to identify project traffic generation characteristics to determine potential project traffic related impacts on the local street system and to develop the necessary mitigation measures required for the identified traffic impacts. The following intersections were incorporated into this traffic study in accordance with the City of Colorado Springs standards and requirements:

- Old Ranch Road & Voyager Parkway (#1)
- Old Ranch Road & Lexington Drive (#2)
- Old Ranch Road & Chapel Ridge Drive (#3)
- Old Ranch Road & Powers Boulevard Southbound Ramp (#4)
- Old Ranch Road & Powers Boulevard Northbound Ramp (#5)

In addition, two (2) proposed full movement accesses along the extension of Chapel Ridge Drive (#6 & #7) were evaluated as the main public access intersections for the project.

Regional access to Ovation will be provided by Interstate 25 (I-25) and Powers Boulevard (SH-21). Primary access will be provided by Old Ranch Road. Direct access will be provided by an extension of Chapel Ridge Drive to the north of Old Ranch Road, within the project property.

Based on the concept plan with 360 single family homes the Ovation property is expected to generate approximately 3,278 weekday daily trips, with 238 of these trips occurring during the morning peak hour and 331 of these trips occurring during the afternoon peak hour.

Based on the analysis presented in this report, Kimley-Horn believes Ovation will be successfully incorporated into the existing and future roadway network. Analysis of the existing street network,

the proposed project development, and expected traffic volumes resulted in the following recommendations:

2025 Recommendations:

- The signal timings at the intersection of Old Ranch Road and Voyager Parkway (#1) may need to be optimized during the morning peak hour by increasing the green time for the eastbound and westbound approaches by eight (8) seconds and decreasing the green time for the northbound and southbound approaches by eight (8) seconds.
- The threshold for requiring an access permit along Colorado Department of Transportation (CDOT) roadways occurs when project traffic is anticipated to increase the existing access traffic volumes by more than 20 percent. Based on traffic projections, the addition of project traffic on the north leg at the Old Ranch Road and Powers Boulevard Southbound Ramp (#4) intersection are not anticipated to increase existing access traffic volumes by more than 20 percent during the afternoon peak hour. Therefore, an access permit is not anticipated to be needed at this intersection as development occurs.
- With completion of the Ovation project, access to the project will be provided by an extension of Chapel Ridge Drive to the north of the existing terminus, into the project property. Intersection analysis was provided for the first two intersections (#6 & #7) along this extension of Chapel Ridge Drive. It is recommended that a R1-1 “STOP” sign be installed on the eastbound and westbound approaches at the Chapel Ridge Drive North Access (#6) and a R1-1 “STOP” sign be installed on the westbound approach at the Chapel Ridge Drive South Access (#7). Additionally, it is recommended that Chapel Ridge Drive be restriped as a three-lane section with a two-way left turn lane.
- To improve pedestrian safety the City of Colorado Spring could explore the addition of crosswalks with rectangular rapid flashing beacons (RRFB) at the intersection of Rhinestone Drive and Chapel Ridge Drive, just to the south of the project site.

2045 Recommendations:

- The signal timings at the Old Ranch Road and Voyager Parkway (#1) may need to be optimized during the afternoon peak hour by increasing the green time for the southbound left turn movement by 10 seconds and the southbound through movement by 3.5 seconds and decreasing green time for the northbound left turn by three (3) seconds, the northbound through by 9.5 seconds, and the eastbound and westbound approaches by 0.5 seconds.

Additionally, the signal timings at this intersection may need to be further optimized during the morning peak hour by increasing the green time for the eastbound and westbound approaches by two (2) seconds, increasing the green time for the northbound and southbound approaches by one (1) second, and decreasing the green time for the northbound and southbound left turn movements by three (3) seconds. If future project traffic volumes are realized by 2045, the southbound and westbound left turn lanes at this intersection may need to be extended to 325 feet. Additionally, the westbound right turn lane may need to be restriped as a continuous lane with City of Colorado Springs planned improvements along Old Ranch Road.

- The signal timings at the intersection of Old Ranch Road and Powers Boulevard Southbound Ramp (#4) may need to be optimized during the morning peak hour by increasing green time for the westbound left turn movement by six (6) seconds and westbound through movement by six (6) and decreasing green time for the southbound approach by six (6) seconds.
- The signal timings at the Old Ranch Road and Powers Boulevard Northbound Ramp (#5) intersection may need to be optimized during the morning peak hour by decreasing green time for the eastbound left turn movement by six (6) seconds, decreasing the green time for the eastbound through movement by 21 seconds, decreasing the green time for the westbound through movement by 15 seconds, and increasing green time for the northbound approach by 21 seconds.

General Recommendations:

- Any onsite or offsite improvements should be incorporated into the Civil Drawings and conform to standards of the City of Colorado Springs and the Manual on Uniform Traffic Control Devices (MUTCD) – 2009 Edition.

2.0 INTRODUCTION

Kimley-Horn and Associates, Inc. has prepared this report to document the results of a Traffic Impact Study for the Ovation residential project proposed to be located along Chapel Ridge Drive between Powers Boulevard (SH-21) and Old Ranch Road in Colorado Springs, Colorado. A vicinity map illustrating the Ovation development location is shown in **Figure 1**. The Ovation property is shown to include a maximum of 360 single-family homes. It is expected that Ovation will be completed in the next few years; therefore, analysis was conducted for the 2025 short-term buildout horizon as well as the 2045 long-term twenty-year planning horizon.

The purpose of this traffic study is to identify project traffic generation characteristics to determine potential project traffic related impacts on the local street system and to develop the necessary mitigation measures required for the identified traffic impacts. The following intersections were incorporated into this traffic study in accordance with the City of Colorado Springs standards and requirements:

- Old Ranch Road & Voyager Parkway (#1)
- Old Ranch Road & Lexington Drive (#2)
- Old Ranch Road & Chapel Ridge Drive (#3)
- Old Ranch Road & Powers Boulevard Southbound Ramp (#4)
- Old Ranch Road & Powers Boulevard Northbound Ramp (#5)

In addition, two (2) proposed full movement accesses along the extension of Chapel Ridge Drive (#6 & #7) were evaluated as the main public access intersections for the project.

Regional access to Ovation will be provided by Interstate 25 (I-25) and Powers Boulevard (SH-21). Primary access will be provided by Old Ranch Road. Direct access will be provided by an extension of Chapel Ridge Drive to the north of Old Ranch Road, within the project property.

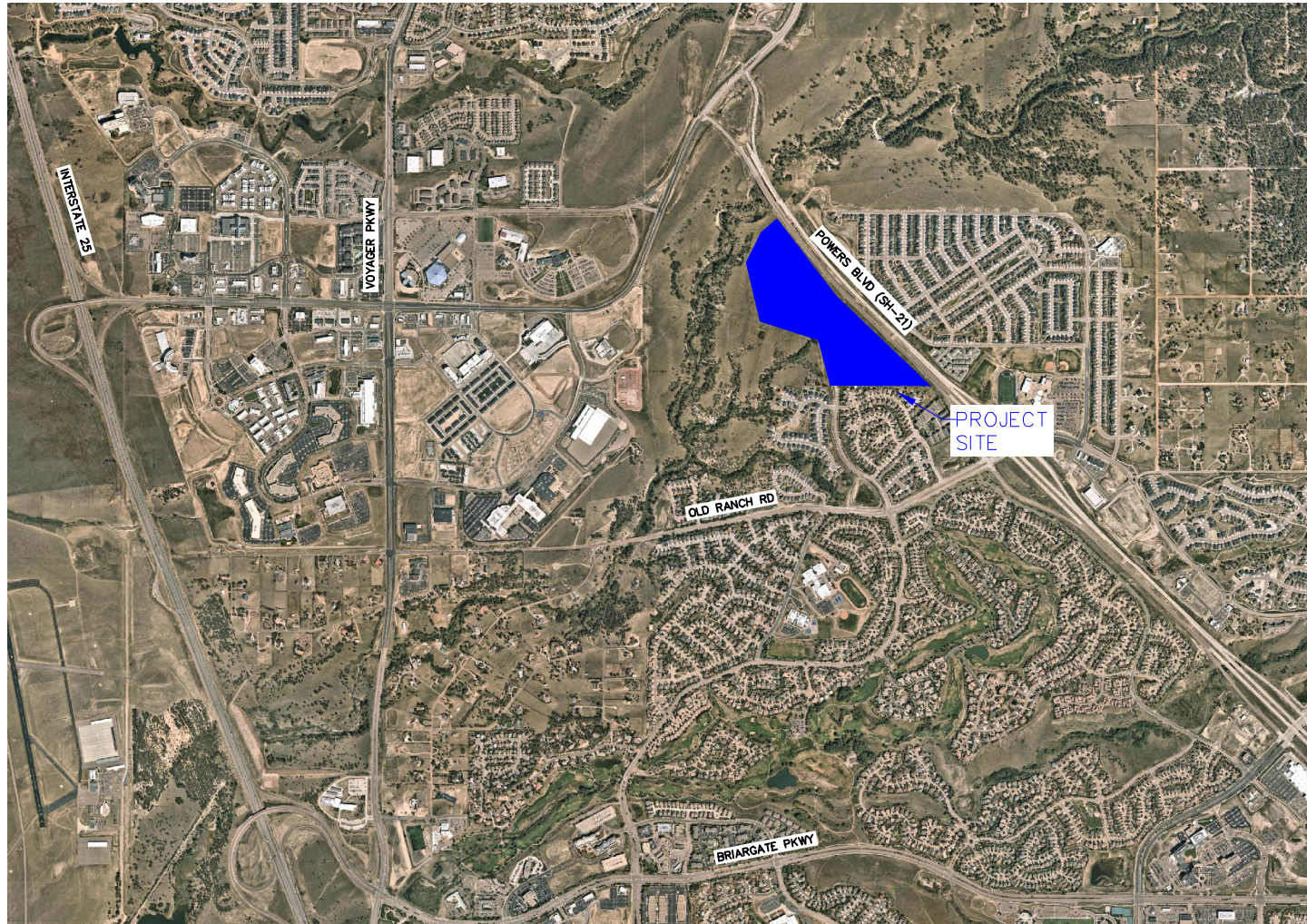

FIGURE 1
OVATION
COLORADO SPRINGS, COLORADO
VICINITY MAP

3.0 EXISTING AND FUTURE CONDITIONS

3.1 Existing Study Area

The existing site is comprised of vacant land. North of the site is more vacant land, single family homes, and Powers Boulevard. To the south are single family homes. East of the project site are single family homes and Powers Boulevard. To the west is industrial and commercial land, multifamily homes, and the Pikes Peak State College – Rampart Range Campus.

3.2 Existing Roadway Network

Old Ranch Road extends east/west with two through lanes of travel in each direction and a posted speed limit ranging from 30 to 45 miles per hour. Voyager Parkway extends northbound and southbound with two through lanes in each direction. The posted speed limit along Voyager Parkway is 50 miles per hour northbound south of Old Ranch Road, 55 miles per hour northbound north of Old Ranch Road, and 55 miles per hour southbound in the project vicinity. Lexington Drive provides one through lane in each direction extending northbound and southbound with a posted speed limit of 25 miles per hour. Chapel Ridge Drive provides two through lanes of travel, northbound and southbound.

The signalized intersection of Old Ranch Road and Voyager Parkway (#1) operates with permissive-only left turn phasing on the east-west Old Ranch Road legs and protected-permissive left turn phasing on the north-south Voyager Parkway legs. The northbound and southbound approaches provide a left turn lane, two through lanes, and a right turn lane. The eastbound approach provides one left turn lane and a shared through/right turn lane. The westbound approach consists of one left turn lane, one through lane, and one right turn lane. An aerial photo of the existing intersection configuration is below (north is up - typical).



Old Ranch Road & Voyager Parkway (#1)

The unsignalized intersection of Old Ranch Road and Lexington Drive (#2) operates with stop control on the northbound and southbound Lexington Drive approaches. The northbound approach provides a two-way left turn lane, one through lane, and a right turn lane. The southbound approach provides one lane for shared movements. The eastbound approach consists of a two-way left turn lane, two through lanes, and a right turn lane. The westbound approach consists of one left turn lane and two through lanes with the outside lane being a shared through/right turn lane. An aerial photo of the existing intersection configuration is below.



Old Ranch Road & Lexington Drive (#2)

The signalized intersection of Old Ranch Road and Chapel Ridge Road (#3) operates with protected-permissive left turn phasing on all four approaches. All four approaches consist of one left turn lane, two through lanes, and a right turn lane. An aerial photo of the existing intersection configuration is below.



Old Ranch Road & Chapel Ridge Road (#3)

The signalized intersection of Old Ranch Road and Powers Boulevard Southbound Ramp (#4) operates with protected-permitted left turn phasing on the westbound Old Ranch Road leg. The southbound approach consists of a left turn lane, a shared left/through/right turn lane, and a right turn lane operating with free movements. The eastbound approach provides two through lanes and a separate right turn lane operating with free right turn movements. The westbound approach consists of one left turn lane and two through lanes. An aerial photo of the existing intersection configuration is below.



Old Ranch Road & Powers Boulevard Southbound Ramp (#4)

The signalized intersection of Old Ranch Road and Powers Boulevard Northbound Ramp (#5) operates with protected-permitted left turn phasing on the eastbound Old Ranch Road leg. The northbound approach consists of a left turn lane, a shared left/through/right turn lane, and a right turn lane operating with yield-controlled right turn movements. The eastbound approach consists of one left turn lane and two through lanes. The westbound approach provides two through lanes and a right turn lane operating with free right turn movements. An aerial photo of the existing intersection configuration is below.



Old Ranch Road & Powers Boulevard Northbound Ramp (#5)

The intersection lane configuration and control for the study area intersections are shown in **Figure 2**.

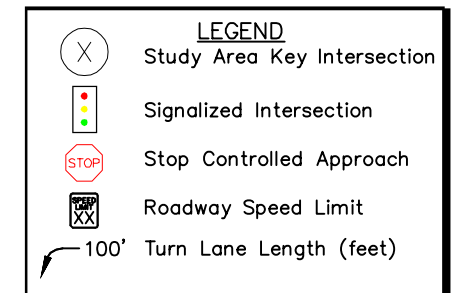
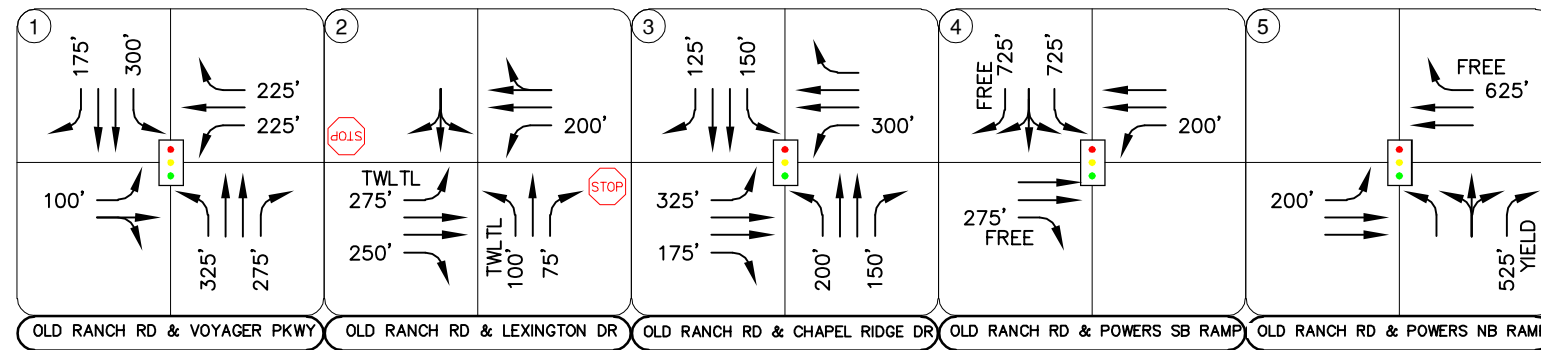

FIGURE 2
 OVATION
 COLORADO SPRINGS, COLORADO
 EXISTING GEOMETRY AND CONTROL

3.3 Existing Traffic Volumes

Existing turning movement counts were conducted at the study intersections on Thursday, March 16, 2023, during the weekday morning and afternoon peak hours. The counts were conducted during the morning and afternoon peak hours of adjacent street traffic in 15-minute intervals from 7:00 AM to 9:00 AM and 4:00 PM to 6:00 PM on this count date. The existing intersection traffic volumes are shown in **Figure 3** with count sheets provided in **Appendix A**.

3.4 Unspecified Development Traffic Growth

According to information provided on the website for the Colorado Department of Transportation (CDOT), the 20-year growth factor along SH-21 (Powers Boulevard) in the vicinity of the site is 1.36. The 20-year growth factor equates to annual growth rate of 1.5 percent. Traffic information from the CDOT Online Transportation Information System (OTIS) website is included in **Appendix B**. This annual growth rate was used to estimate near term 2025 and long term 2045 traffic volume projections at the key intersections. Background traffic volumes for 2025 and 2045 are shown in **Figures 4** and **5**, respectively.



①	②	③	④	⑤
0(3) 488(624) 155(282) 253(97) 1(1) 262(124)	6(7) 0(1) 2(10) 1(11) 501(248) 268(53)	72(34) 10(6) 48(25) 12(20) 667(219) 110(80)	48(31) 0(2) 111(92) 740(296) 314(209)	134(105) 775(333)
3(2) 4(0) 2(2) 1(6) 628(583) 100(256)	0(4) 226(552) 65(18) 57(20) 2(1) 232(62)	23(70) 385(409) 52(49) 66(37) 7(16) 155(80)	367(296) 240(213)	36(31) 447(382) 249(139) 0(2) 307(215)
OLD RANCH RD & VOYAGER PKWY	OLD RANCH RD & LEXINGTON DR	OLD RANCH RD & CHAPEL RIDGE DR	OLD RANCH RD & POWERS SB RAMP	OLD RANCH RD & POWERS NB RAMP
Thurs, March 16, 2023 7:30 to 8:30AM (4:45 to 5:45PM)	Thurs, March 16, 2023 7:30 to 8:30AM (4:00 to 5:00PM)	Thurs, March 16, 2023 7:15 to 8:15AM (4:30 to 5:30PM)	Thurs, March 16, 2023 7:15 to 8:15AM (4:00 to 5:00PM)	Thurs, March 16, 2023 7:15 to 8:15AM (4:30 to 5:30PM)

FIGURE 3
OVATION
COLORADO SPRINGS, COLORADO
2023 EXISTING TRAFFIC VOLUMES

LEGEND	
⊗	Study Area Key Intersection
XXX(XXX)	Weekday AM(PM) Peak Hour Traffic Volumes
XX,X00	Estimated Daily Traffic Volume



1	2	3	4	5
0(3) 503(643) 160(291) 261(100) 1(1) 270(128)	6(7) 0(1) 2(10) 1(11) 516(255) 276(55)	72(34) 10(6) 48(25) 12(20) 687(226) 113(82)	49(32) 0(2) 114(95) 762(305) 323(215)	138(108) 798(343)
3(2) 4(0) 2(2) 1(6) 647(601) 103(264)	0(4) 233(569) 67(19) 59(21) 2(1) 239(64)	23(70) 397(421) 54(50) 68(38) 7(16) 160(82)	378(305) 247(219)	37(32) 461(394) 257(143) 0(2) 316(221)
OLD RANCH RD & VOYAGER PKWY	OLD RANCH RD & LEXINGTON DR	OLD RANCH RD & CHAPEL RIDGE DR	OLD RANCH RD & POWERS SB RAMP	OLD RANCH RD & POWERS NB RAMP

FIGURE 4
 OVATION
 COLORADO SPRINGS, COLORADO
 2025 BACKGROUND TRAFFIC VOLUMES

LEGEND

(X) Study Area Key Intersection

XXX(XXX) Weekday AM(PM)
 Peak Hour Traffic Volumes

XX,X00 Estimated Daily Traffic Volume



1	2	3	4	5
0(4) 677(866) 215(391) 351(135) 1(1) 364(172)	6(7) 0(1) 2(10) 1(11) 695(344) 372(74)	72(34) 10(6) 48(25) 12(20) 926(304) 153(111)	67(43) 0(3) 154(128) 1027(411) 436(290)	186(146) 1075(462)
4(3) 6(0) 3(3) 1(8) 871(809) 139(355)	0(4) 314(766) 90(25) 79(28) 2(1) 322(86)	23(70) 534(568) 72(68) 92(51) 7(16) 215(111)	509(411) 333(296)	50(43) 620(530) 346(193) 0(3) 426(298)
OLD RANCH RD & VOYAGER PKWY	OLD RANCH RD & LEXINGTON DR	OLD RANCH RD & CHAPEL RIDGE DR	OLD RANCH RD & POWERS SB RAMP	OLD RANCH RD & POWERS NB RAMP

FIGURE 5
 OVATION
 COLORADO SPRINGS, COLORADO
 2045 BACKGROUND TRAFFIC VOLUMES

LEGEND

(X) Study Area Key Intersection

XXX(XXX) Weekday AM(PM)
 Peak Hour Traffic Volumes

XX,X00 Estimated Daily Traffic Volume

4.0 PROJECT TRAFFIC CHARACTERISTICS

4.1 Trip Generation

Site-generated traffic estimates are determined through a process known as trip generation. Rates and equations are applied to the proposed land use to estimate traffic generated by the development during a specific time interval. The acknowledged source for trip generation rates is the *Trip Generation Manual*¹ published by the Institute of Transportation Engineers (ITE). ITE has established trip rates in nationwide studies of similar land uses. For this study, Kimley-Horn used the ITE Trip Generation Report fitted curve equations that apply to Single Family Detached Housing (ITE Land Use Code 210), for traffic associated with the development.

Based on the maximum of 360 single family homes, the Ovation property is expected to generate approximately 3,278 weekday daily trips, with 238 of these trips occurring during the morning peak hour and 331 of these trips occurring during the afternoon peak hour. Calculations were based on the procedure and information provided in the ITE *Trip Generation Manual, 11th Edition – Volume 1: User’s Guide and Handbook, 2021*. **Table 1** summarizes the estimated trip generation for the Ovation property. Trip generation worksheets are included in **Appendix C**.

Table 1 – Ovation Traffic Generation

Land Use and Size	Weekday Vehicle Trips						
	Daily	AM Peak Hour			PM Peak Hour		
		In	Out	Total	In	Out	Total
Single Family Detached Housing (210) – 360 Dwelling Units	3,278	62	176	238	209	122	331

4.2 Trip Distribution

Distribution of site traffic on the street system was based on the area street system characteristics, existing traffic patterns, existing and anticipated surrounding employment, school, and attraction information, and the proposed access system for the project. The directional distribution of traffic is a means to quantify the percentage of site-generated traffic that approaches the site from a given direction and departs the site back to the original source. The project trip distribution for the proposed development is illustrated in **Figure 6**.

¹ Institute of Transportation Engineers, *Trip Generation Manual*, Eleventh Edition, Washington DC, 2021.

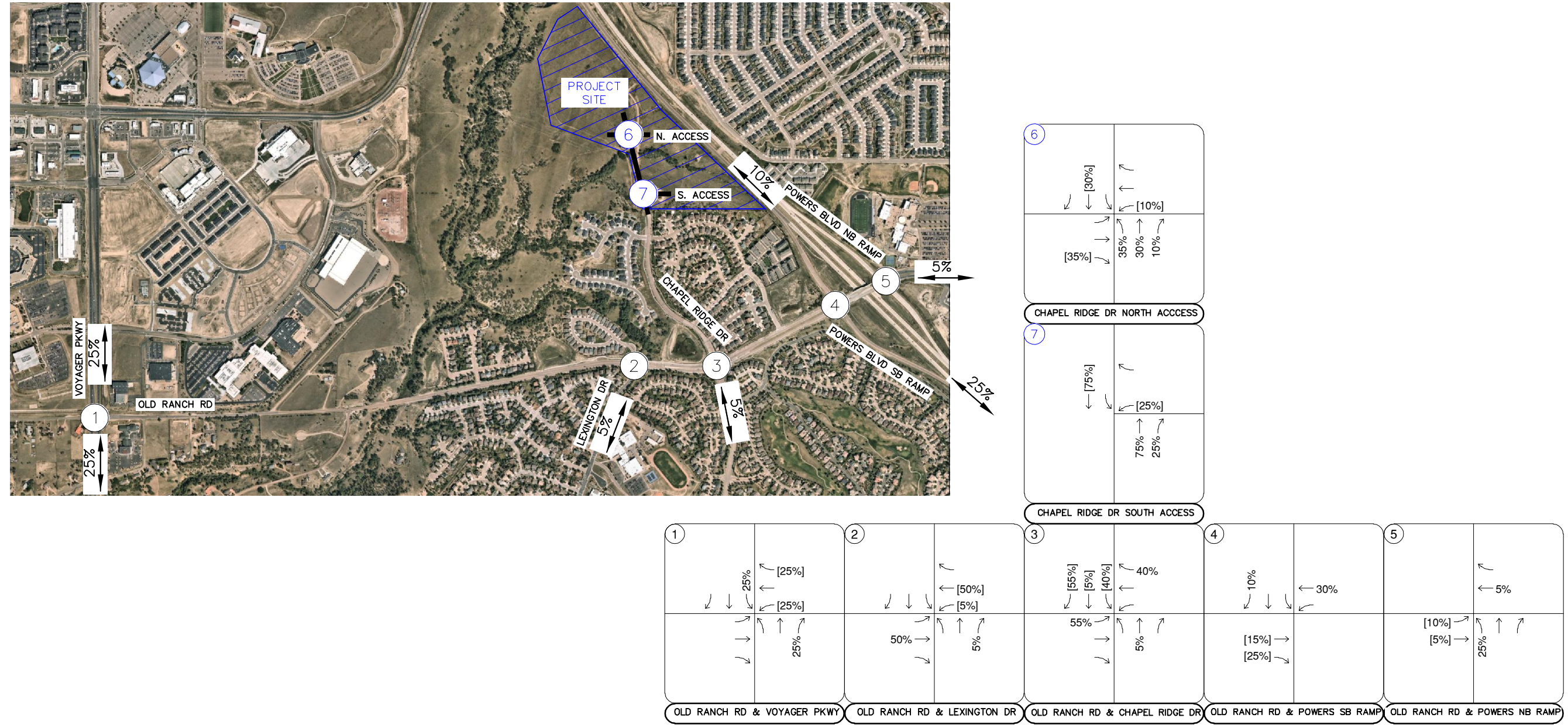

FIGURE 6
 OVATION
 COLORADO SPRINGS, COLORADO
 PROJECT TRIP DISTRIBUTION

LEGEND

- (X) Study Area Key Intersection
- (X) Project Access Intersection
- XX% External Trip Distribution Percentage
- XX%[XX%] Entering[Exiting] Trip Distribution Percentage

4.3 Traffic Assignment

Ovation traffic assignment was obtained by applying the project trip distribution to the estimated traffic generation of the development shown in **Table 1**. Traffic assignment is shown in **Figure 7**.

4.4 Total (Background Plus Project) Traffic

Site traffic volumes were added to the background volumes to represent estimated traffic conditions for the short-term 2025 buildout horizon and long-term 2045 twenty-year planning horizon. These total traffic volumes for the study area are illustrated for the 2025 and 2045 horizon years in **Figures 8** and **9**, respectively.



6	← 53(37)	18(12)
62(43)	22(73)	19(63)
	6(21)	

CHAPEL RIDGE DR NORTH ACCESS

7	← 132(92)	44(31)
	47(157)	16(52)

CHAPEL RIDGE DR SOUTH ACCESS

1	← 16(52)	44(31)	2	← 88(61)	3	97(67)	25(84)	4	6(21)	← 19(63)	5	← 3(10)
	44(31)		9(6)	9(6)	70(49)	34(115)	3(10)	26(18)	44(31)	18(12)	9(6)	16(52)
	16(52)	31(105)	3(10)									

OLD RANCH RD & VOYAGER PKWY OLD RANCH RD & LEXINGTON DR OLD RANCH RD & CHAPEL RIDGE DR OLD RANCH RD & POWERS SB RAMP OLD RANCH RD & POWERS NB RAMP

LEGEND

- (X) Study Area Key Intersection
- (X) Project Access Intersection
- XXX(XXX) Weekday AM(PM) Peak Hour Traffic Volumes
- [XX,X00] Estimated Daily Traffic Volume

FIGURE 7
 OVATION
 COLORADO SPRINGS, COLORADO
 PROJECT TRAFFIC ASSIGNMENT



6	← 53(37)	18(12)
	62(43)	22(73) 19(63) 6(21)

CHAPEL RIDGE DR NORTH ACCESS

7	← 132(92)	44(31)
		47(157) 16(52)

CHAPEL RIDGE DR SOUTH ACCESS

1	2	3	4	5																																																																																				
<table border="1"> <tr> <td>0(3)</td> <td>503(643)</td> <td>176(343)</td> <td>305(131)</td> </tr> <tr> <td>3(2)</td> <td>1(1)</td> <td>314(159)</td> <td></td> </tr> <tr> <td>4(0)</td> <td>647(601)</td> <td>119(316)</td> <td></td> </tr> <tr> <td>2(2)</td> <td>1(6)</td> <td></td> <td></td> </tr> </table>	0(3)	503(643)	176(343)	305(131)	3(2)	1(1)	314(159)		4(0)	647(601)	119(316)		2(2)	1(6)			<table border="1"> <tr> <td>6(7)</td> <td>0(1)</td> <td>2(10)</td> <td>1(11)</td> </tr> <tr> <td>0(4)</td> <td>264(674)</td> <td>67(19)</td> <td>604(316)</td> </tr> <tr> <td>59(21)</td> <td>2(1)</td> <td>242(74)</td> <td>285(61)</td> </tr> <tr> <td></td> <td></td> <td></td> <td></td> </tr> </table>	6(7)	0(1)	2(10)	1(11)	0(4)	264(674)	67(19)	604(316)	59(21)	2(1)	242(74)	285(61)					<table border="1"> <tr> <td>169(101)</td> <td>19(12)</td> <td>118(74)</td> <td>37(104)</td> </tr> <tr> <td>57(185)</td> <td>687(226)</td> <td>113(82)</td> <td></td> </tr> <tr> <td>397(421)</td> <td>68(38)</td> <td>10(26)</td> <td>160(82)</td> </tr> <tr> <td>54(50)</td> <td></td> <td></td> <td></td> </tr> </table>	169(101)	19(12)	118(74)	37(104)	57(185)	687(226)	113(82)		397(421)	68(38)	10(26)	160(82)	54(50)				<table border="1"> <tr> <td>55(53)</td> <td>0(2)</td> <td>114(95)</td> <td>781(368)</td> </tr> <tr> <td>404(323)</td> <td>291(250)</td> <td></td> <td>323(215)</td> </tr> <tr> <td></td> <td></td> <td></td> <td></td> </tr> <tr> <td></td> <td></td> <td></td> <td></td> </tr> </table>	55(53)	0(2)	114(95)	781(368)	404(323)	291(250)		323(215)									<table border="1"> <tr> <td>55(44)</td> <td>470(400)</td> <td>273(195)</td> <td>0(2)</td> <td>316(221)</td> </tr> <tr> <td></td> <td></td> <td></td> <td></td> <td></td> </tr> <tr> <td></td> <td></td> <td></td> <td></td> <td></td> </tr> <tr> <td></td> <td></td> <td></td> <td></td> <td></td> </tr> </table>	55(44)	470(400)	273(195)	0(2)	316(221)															
0(3)	503(643)	176(343)	305(131)																																																																																					
3(2)	1(1)	314(159)																																																																																						
4(0)	647(601)	119(316)																																																																																						
2(2)	1(6)																																																																																							
6(7)	0(1)	2(10)	1(11)																																																																																					
0(4)	264(674)	67(19)	604(316)																																																																																					
59(21)	2(1)	242(74)	285(61)																																																																																					
169(101)	19(12)	118(74)	37(104)																																																																																					
57(185)	687(226)	113(82)																																																																																						
397(421)	68(38)	10(26)	160(82)																																																																																					
54(50)																																																																																								
55(53)	0(2)	114(95)	781(368)																																																																																					
404(323)	291(250)		323(215)																																																																																					
55(44)	470(400)	273(195)	0(2)	316(221)																																																																																				
OLD RANCH RD & VOYAGER PKWY	OLD RANCH RD & LEXINGTON DR	OLD RANCH RD & CHAPEL RIDGE DR	OLD RANCH RD & POWERS SB RAMP	OLD RANCH RD & POWERS NB RAMP																																																																																				

LEGEND

- (X) Study Area Key Intersection
- (X) Project Access Intersection
- XXX(XXX) Weekday AM(PM) Peak Hour Traffic Volumes
- XX,X00 Estimated Daily Traffic Volume

FIGURE 8
 OVATION
 COLORADO SPRINGS, COLORADO
 2025 TOTAL TRAFFIC VOLUMES



6	← 53(37)	18(12)
62(43)	↔ 22(73) ↔ 19(63) ↔ 6(21)	

CHAPEL RIDGE DR NORTH ACCESS

7	← 132(92)	44(31)
	↔ 47(157) ↔ 16(52)	

CHAPEL RIDGE DR SOUTH ACCESS

1	2	3	4	5
0(4) ↙ 677(866) ↘ 231(443) ↖ 395(166) ↗ 1(1) ↘ 408(203)	6(7) ↙ 0(1) ↘ 2(10) ↖ 1(11) ↗ 783(405) ↘ 381(80)	169(101) ↙ 19(12) ↘ 118(74) ↖ 37(104) ↗ 926(304) ↘ 153(111)	73(64) ↙ 0(3) ↘ 154(128) ↖ 1046(474) ↗ 436(290)	186(146) ↙ 1078(472)
4(3) 6(0) 3(3)	0(4) 345(871) 90(25)	57(185) 534(568) 72(68)	535(429) 377(327)	68(55) 629(536)
1(8) 871(809) 155(407)	79(28) 2(1) 325(96)	92(51) 10(26) 215(111)	362(245) 0(3) 426(298)	
OLD RANCH RD & VOYAGER PKWY	OLD RANCH RD & LEXINGTON DR	OLD RANCH RD & CHAPEL RIDGE DR	OLD RANCH RD & POWERS SB RAMP	OLD RANCH RD & POWERS NB RAMP

LEGEND

- X Study Area Key Intersection
- X Project Access Intersection
- XXX(XXX) Weekday AM(PM)
Peak Hour Traffic Volumes
- XX,X00 Estimated Daily Traffic Volume

FIGURE 9
OVATION
 COLORADO SPRINGS, COLORADO
 2045 TOTAL TRAFFIC VOLUMES

5.0 TRAFFIC OPERATIONS ANALYSIS

Kimley-Horn’s analysis of traffic operations in the site vicinity was conducted to determine potential capacity deficiencies in the 2025 and 2045 development horizons at the identified key intersections. The acknowledged source for determining overall capacity is the *Highway Capacity Manual (HCM)*².

5.1 Analysis Methodology

Capacity analysis results are listed in terms of Level of Service (LOS). LOS is a qualitative term describing operating conditions a driver will experience while traveling on a particular street or highway during a specific time interval. It ranges from A (very little delay) to F (long delays and congestion). For intersections and roadways in this study area, standard traffic engineering practice recommends overall intersection LOS D and movement/approach LOS E as the minimum desirable thresholds for acceptable operations. **Table 2** shows the definition of level of service for signalized and unsignalized intersections.

Table 2 – Level of Service Definitions

Level of Service	Signalized Intersection Average Total Delay (sec/veh)	Unsignalized Intersection Average Total Delay (sec/veh)
A	≤ 10	≤ 10
B	> 10 and ≤ 20	> 10 and ≤ 15
C	> 20 and ≤ 35	> 15 and ≤ 25
D	> 35 and ≤ 55	> 25 and ≤ 35
E	> 55 and ≤ 80	> 35 and ≤ 50
F	> 80	> 50

Definitions provided from the Highway Capacity Manual, Sixth Edition, Transportation Research Board, 2016.

Study area intersections were analyzed based on average total delay analysis for signalized and unsignalized intersections. Under the unsignalized analysis, the LOS for a two-way stop-controlled intersection is determined by the computed or measured control delay and is defined for each minor movement. LOS for a two-way stop-controlled intersection is not defined for the intersection as a whole. LOS for signalized, roundabout, and all-way stop controlled intersections are defined for each approach and for the overall intersection.

² Transportation Research Board, *Highway Capacity Manual*, Sixth Edition, Washington DC, 2016.

5.2 Key Intersection Operational Analysis

Calculations for the operational level of service at the key intersections for the study area are provided in **Appendix D**. The existing year analysis is based on the lane geometry and intersection control shown in **Figure 2**. Existing peak hour factors were utilized in the existing, 2025, and 2045 horizon analysis years. The signalized intersection analysis utilizes signal timing provided by the City of Colorado Springs provided in **Appendix E**. Synchro traffic analysis software was used to analyze the signalized, and unsignalized key intersections for HCM level of service.

Old Ranch Road & Voyager Parkway (#1)

The signalized intersection of Old Ranch Road and Voyager Parkway (#1) operates with permissive-only left turn phasing on the east-west Old Ranch Road legs and protected-permissive left turn phasing on the north-south Voyager Parkway legs. The intersection operates acceptably at LOS B during both peak hours under existing conditions. With project traffic, this intersection is anticipated to continue operating at an acceptable level of service throughout the 2045 horizon. However, the signal timings at this intersection may need to be optimized by 2025 during the morning peak hour by increasing the green time for the eastbound and westbound approaches by eight (8) seconds and decreasing the green time for the northbound and southbound approaches by eight (8) seconds. By 2045, the signal timings at this intersection may need to be optimized during the afternoon peak hour by increasing the green time for the southbound left turn movement by 10 seconds and the southbound through movement by 3.5 seconds and decreasing green time for the northbound left turn by three (3) seconds, the northbound through by 9.5 seconds, and the eastbound and westbound approaches by 0.5 seconds. Additionally, the signal timings at this intersection may need to be further optimized during the morning peak hour by increasing the green time for the eastbound and westbound approaches by two (2) seconds, increasing the green time for the northbound and southbound approaches by one (1) second, and decreasing the green time for the northbound and southbound left turn movements by three (3) seconds. The optimized signal timings will help alleviate queue issues during the peak hours. **Table 3** provides the results of the LOS analysis conducted at this intersection.

Table 3 – Old Ranch Road & Voyager Parkway (#1) LOS Results

Scenario	AM Peak Hour		PM Peak Hour	
	Delay (sec/veh)	LOS	Delay (sec/veh)	LOS
2023 Existing	19.2	B	12.0	B
2025 Background	19.7	B	12.3	B
2025 Background Plus Project	22.9	C	14.6	B
2025 Background Plus Project #	21.6	C	-	-
2045 Background	32.7	C	20.9	C
2045 Background Plus Project #	54.0	D	24.0	C

= Optimized Signal Timings

Old Ranch Road & Lexington Drive (#2)

The unsignalized intersection of Old Ranch Road and Lexington Drive (#2) operates with stop control on the northbound and southbound Lexington Drive approaches. The intersection movements operate acceptably at LOS C or better during both peak hours under existing conditions. With project traffic, all movements are anticipated to continue operating at an acceptable level of service throughout the 2025 horizon. With or without the addition of project traffic, some movements at this intersection are anticipated to operate with long vehicle delays during the morning peak hour in the 2045 horizon. A signal warrant analysis was completed for this intersection with 2045 total traffic volumes, and it was found that a signal is not anticipated to be warranted at this intersection. Signal warrant analysis is provided in **Appendix F**. If desired, the City of Colorado Springs may consider signalizing this intersection by 2045 due to the curvature of the roadway, the surrounding schools, and the additional through volume along Old Ranch Road. **Table 4** provides the results of the LOS analysis conducted at this intersection.

Table 4 – Old Ranch Road & Lexington Drive (#2) LOS Results

Scenario	AM Peak Hour		PM Peak Hour	
	Delay (sec/veh)	LOS	Delay (sec/veh)	LOS
2023 Existing				
Northbound Left	24.6	C	15.4	C
Northbound Through	24.4	C	15.1	C
Northbound Right	10.8	B	10.7	B
Eastbound Left	0.0	A	7.5	A
Westbound Left	9.0	A	8.9	A
Southbound Approach	14.1	B	12.0	B
2025 Background				
Northbound Left	26.4	D	15.8	C
Northbound Through	25.5	D	15.3	C
Northbound Right	10.9	B	10.8	B
Eastbound Left	0.0	A	7.5	A
Westbound Left	9.1	A	9.0	A
Southbound Approach	14.7	B	12.2	B
2025 Background Plus Project				
Northbound Left	29.2	D	17.8	C
Northbound Through	28.9	D	16.9	C
Northbound Right	11.2	B	11.4	B
Eastbound Left	0.0	A	7.5	A
Westbound Left	9.3	A	9.5	A
Southbound Approach	16.0	C	13.1	B
2045 Background				
Northbound Left	71.9	F	20.5	C
Northbound Through	45.6	E	18.6	C
Northbound Right	13.0	B	12.2	B
Eastbound Left	0.0	A	7.6	A
Westbound Left	10.6	B	10.1	B
Southbound Approach	>300	F	14.4	B
2045 Background Plus Project				
Northbound Left	88.4	F	23.5	C
Northbound Through	54.5	F	20.6	C
Northbound Right	13.5	B	13.1	B
Eastbound Left	0.0	A	7.7	A
Westbound Left	11.0	B	10.7	B
Southbound Approach	>300	F	15.8	C

Old Ranch Road & Chapel Ridge Drive (#3)

The signalized intersection of Old Ranch Road and Chapel Ridge Road (#3) operates with protected-permissive left turn phasing on all four approaches. The intersection operates acceptably at LOS C during both peak hours under existing conditions. With project traffic, this intersection is anticipated to continue operating at an acceptable level of service throughout the 2045 horizon. Therefore, no improvements or modifications are anticipated to be needed at this intersection based on the addition of project traffic and this operational level of service analysis.

Table 5 provides the results of the LOS analysis conducted at this intersection.

Table 5 – Old Ranch Road & Chapel Ridge Drive (#3) LOS Results

Scenario	AM Peak Hour		PM Peak Hour	
	Delay (sec/veh)	LOS	Delay (sec/veh)	LOS
2023 Existing	26.0	C	20.5	C
2025 Background	29.8	C	20.6	C
2025 Background Plus Project	33.2	C	23.6	C
2045 Background	34.1	C	21.8	C
2045 Background Plus Project	38.6	D	24.3	C

Old Ranch Road & Powers Boulevard Southbound Ramp (#4)

The signalized intersection of Old Ranch Road and Powers Boulevard Southbound Ramp (#4) operates with protected-permitted left turn phasing on the westbound Old Ranch Road leg. The intersection operates acceptably at LOS A during both peak hours under existing conditions. With project traffic, this intersection is anticipated to continue operating at an acceptable level of service throughout the 2045 horizon. However, the signal timings at this intersection may need to be optimized during the morning peak hour by increasing green time for the westbound left turn movement by six (6) seconds and westbound through movement by six (6) and decreasing green time for the southbound approach by six (6) seconds. **Table 6** provides the results of the LOS analysis conducted at this intersection.

Table 6 – Old Ranch Road & Powers Boulevard Southbound Ramp (#4) LOS Results

Scenario	AM Peak Hour		PM Peak Hour	
	Delay (sec/veh)	LOS	Delay (sec/veh)	LOS
2023 Existing	5.9	A	6.1	A
2025 Background	6.0	A	6.1	A
2025 Background Plus Project	5.9	A	5.9	A
2045 Background	11.4	B	6.4	A
2045 Background Plus Project	-	-	6.2	A
2045 Background Plus Project #	8.6	A	-	-

= Optimized Signal Timings

Old Ranch Road & Powers Boulevard Northbound Ramp (#5)

The signalized intersection of Old Ranch Road and Powers Boulevard Northbound Ramp (#5) operates with protected-permitted left turn phasing on the eastbound Old Ranch Road leg. The intersection operates acceptably at LOS C or better during both peak hours under existing conditions. With project traffic, this intersection is anticipated to continue operating at an acceptable level of service throughout the 2045 horizon. However, the signal timings at this intersection may need to be optimized during the morning peak hour by decreasing green time for the eastbound left turn movement by six (6) seconds, decreasing the green time for the eastbound through movement by 21 seconds, decreasing the green time for the westbound through movement by 15 seconds, and increasing green time for the northbound approach by 21 seconds. **Table 7** provides the results of the LOS analysis conducted at this intersection.

Table 7 – Old Ranch Road & Powers Boulevard Northbound Ramp (#5) LOS Results

Scenario	AM Peak Hour		PM Peak Hour	
	Delay (sec/veh)	LOS	Delay (sec/veh)	LOS
2023 Existing	31.3	C	10.0	B
2025 Background	33.9	C	10.1	B
2025 Background Plus Project	37.8	D	17.5	B
2045 Background	71.8	E	13.4	B
2045 Background Plus Project	-	-	22.2	C
2045 Background Plus Project #	29.7	C	-	-

Project Accesses

With completion of the Ovation project, access to the project will be provided by an extension of Chapel Ridge Drive to the north of the existing terminus, into the project property. Intersection analysis was provided for the first two assumed intersections (#6 & #7) along this extension of Chapel Ridge Drive. It is recommended that a R1-1 “STOP” sign be installed on the eastbound and westbound approaches at the Chapel Ridge Drive North Access (#6) and a R1-1 “STOP” sign be installed on the westbound approach at the Chapel Ridge Drive South Access (#7). Additionally, it is recommended that Chapel Ridge Drive be restriped as a three-lane section with a center two-way left turn lane. **Table 8** provides the results of the level of service for this project street access. As shown in the table, the project street access intersections along Chapel Ridge Drive are anticipated to have all movements operating with acceptable LOS B or better during the peak hours in both the buildout year 2025 and the 2045 long term horizons. Of note, to improve pedestrian safety the City of Colorado Spring could explore the addition of crosswalks with rectangular rapid flashing beacons (RRFB) at the intersection of Rhinestone Drive and Chapel Ridge Drive, just to the south of the project site. Further, based on coordination with the City of Colorado Springs, the intersection located south of the project development area, Rhinestone Drive and Chapel Ridge Drive, should operate with all-way stop control when Chapel Ridge Drive is extended to the north.

Table 8 – Project Access Level of Service Results

Intersection	2025 Total				2045 Total			
	AM Peak Hour		PM Peak Hour		AM Peak Hour		PM Peak Hour	
	Delay (sec/veh)	LOS	Delay (sec/veh)	LOS	Delay (sec/veh)	LOS	Delay (sec/veh)	LOS
Chapel Ridge Dr N. Access (#6)								
Northbound Left	7.4	A	7.4	A	7.4	A	7.4	A
Eastbound Approach	8.8	A	8.7	A	8.8	A	8.7	A
Westbound Approach	10.0	B	11.0	B	10.0	B	11.0	B
Southbound Left	0.0	A	0.0	A	0.0	A	0.0	A
Chapel Ridge Dr S. Access (#7)								
Westbound Approach	9.9	A	10.0	B	9.9	A	10.0	B
Southbound Left	0.0	A	0.0	A	0.0	A	0.0	A

5.3 CDOT Turn Bay Length Analysis

The threshold for requiring an access permit along Colorado Department of Transportation (CDOT) roadways occurs when project traffic is anticipated to increase the existing access traffic volumes by more than 20 percent. Based on traffic projections, the addition of project traffic on the north leg at the Old Ranch Road and Powers Boulevard Southbound Ramp (#4) intersection are not anticipated to increase existing access traffic volumes by more than 20 percent during the afternoon peak hour. Therefore, an access permit is not anticipated to be needed at this intersection as development occurs.

5.4 Vehicle Queuing Analysis

A vehicle queuing analysis was conducted for the study area intersections. The queuing analysis was performed using Synchro presenting the results of the 95th percentile queue lengths. Results are shown in the following **Table 9** with calculations provided within the level of service operational sheets of **Appendix D** for unsignalized intersections and **Appendix G** for signalized intersections.

Table 9 – Turn Lane Queuing Analysis Results

Intersection Turn Lane	Existing Turn Lane Length (feet)	2025 Calculated Queue (feet)	2025 Recommended Length (feet)	2045 Calculated Queue (feet)	2045 Recommended Length (feet)
Old Ranch Rd & Voyager Pkwy (#1)					
Eastbound Left	100'	25'	100'	25'	100'
Westbound Left	225'	200'	225'	306'	325'
Westbound Right	225'	35'	225'	121'	C
Northbound Left	325'	25'	325'	25'	325'
Northbound Right	275'	50'	275'	71'	275'
Southbound Left	300'	183'	300'	303'	325'
Southbound Right	175'	25'	175'	25'	175'
Old Ranch Rd & Lexington Dr (#2)					
Eastbound Left	TWLTL	25'	TWLTL	25'	TWLTL
Eastbound Right	250'	25'	250'	25'	250'
Westbound Left	200'	50'	200'	75'	200'
Northbound Left	TWLTL	50'	TWLTL	125'	TWLTL
Northbound Right	75'	50'	75'	75'	75'
Old Ranch Rd & Chapel Ridge Dr (#3)					
Eastbound Left	325'	103'	325'	103'	325'
Eastbound Right	175'	25'	175'	25'	175'
Westbound Left	300'	107'	300'	135'	300'
Northbound Left	200'	72'	200'	93'	200'
Northbound Right	150'	41'	150'	43'	150'
Southbound Left	150'	115'	150'	115'	150'
Southbound Right	125'	41'	125'	41'	125'

Intersection Turn Lane	Existing Turn Lane Length (feet)	2025 Calculated Queue (feet)	2025 Recommended Length (feet)	2045 Calculated Queue (feet)	2045 Recommended Length (feet)
Old Ranch Rd & Powers Blvd SB Ramp (#4)					
Eastbound Right	275'	25'	275'	25'	275'
Westbound Left	200'	168'	200'	163'	200'
Southbound Left	725'	84'	725'	115'	725'
Southbound Right	725'	25'	725'	25'	725'
Old Ranch Rd & Powers Blvd NB Ramp (#5)					
Eastbound Left	200'	45'	200'	56'	200'
Westbound Right	625'	25'	625'	25'	625'
Northbound Right	525'	25'	525'	25'	525'
Chapel Ridge Dr N. Access (#6)					
Southbound Left	DNE	25'	TWLTL	25'	TWLTL
Chapel Ridge Dr S. Access (#7)					
Northbound Left	DNE	25'	TWLTL	25'	TWLTL
Southbound Left	DNE	25'	TWLTL	25'	TWLTL

DNE = Does Not Exist; TWLTL = Two-Way Left Turn Lane; C = Continuous Lane; **Red** Text = Storage Deficiency; **Blue** Text = Recommendation

By 2025, it is recommended that Chapel Ridge Drive be restriped as a three-lane roadway with the addition of a center two-way left turn lane.

If future project traffic volumes are realized by 2045, the southbound and westbound left turn lanes at the Old Ranch Road and Voyager Parkway (#1) intersection may both need to be extended to 325 feet. Additionally, the westbound right turn lane may need to be restriped as a continuous lane with City of Colorado Springs planned improvements along Old Ranch Road.

5.5 Improvement Summary

Based on the results of the intersection operational and vehicle queuing analysis, the key intersection recommended improvements and control are shown in **Figure 10** for the 2025 horizon and **Figure 11** for the 2045 horizon.

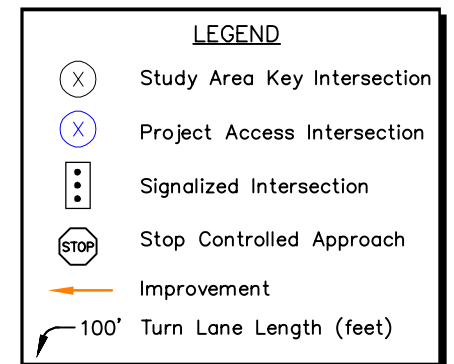
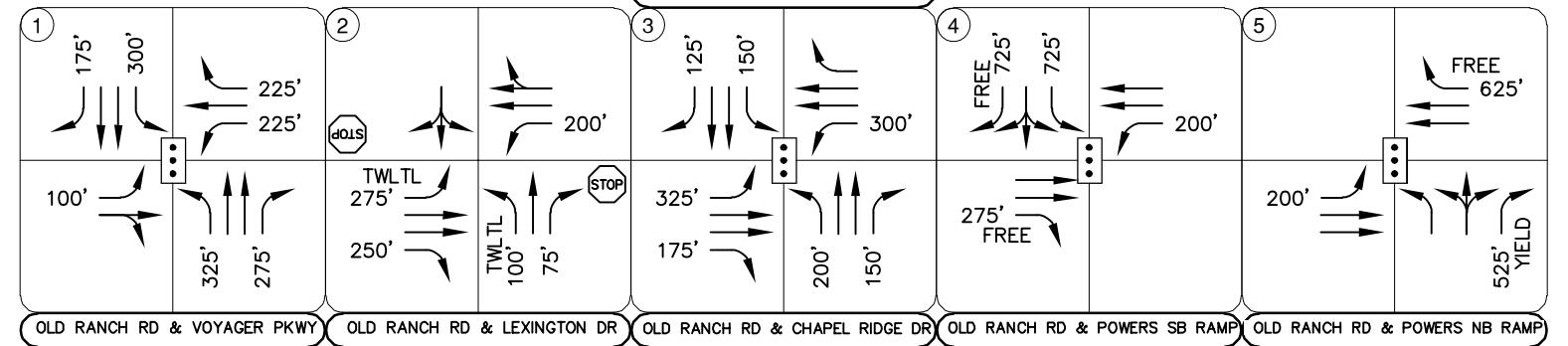
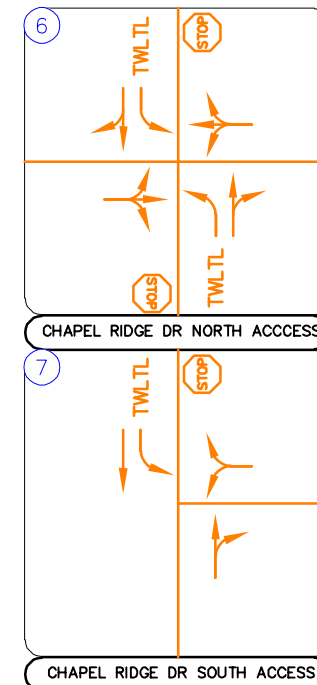

FIGURE 10
 OVATION
 COLORADO SPRINGS, COLORADO
 2025 RECOMMENDED GEOMETRY AND CONTROL

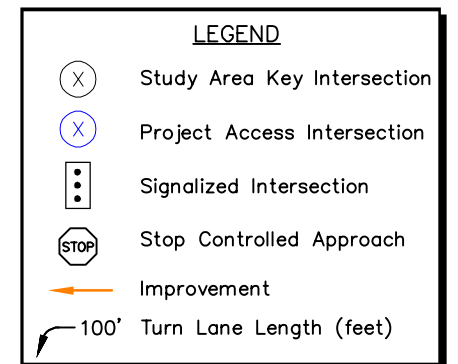
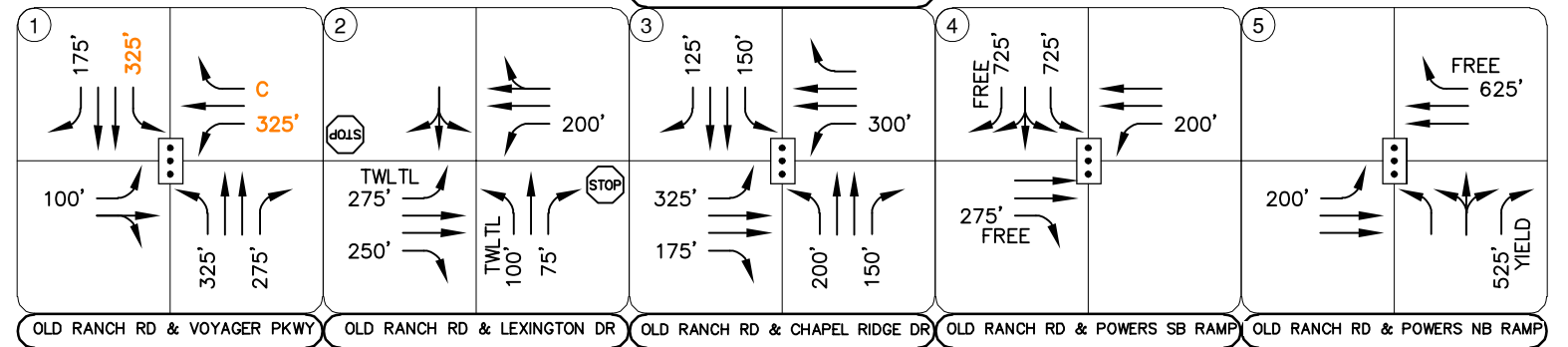
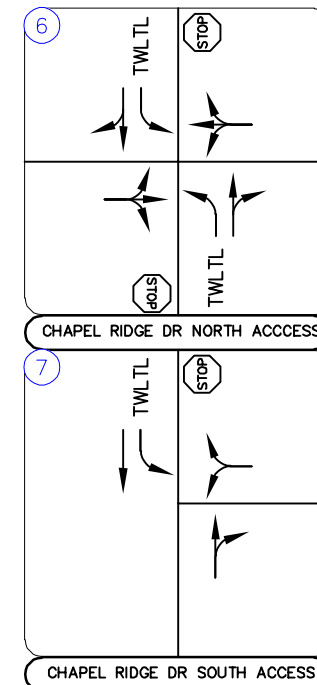

FIGURE 11
 OVATION
 COLORADO SPRINGS, COLORADO
 2045 RECOMMENDED GEOMETRY AND CONTROL

6.0 CONCLUSIONS AND RECOMMENDATIONS

Based on the analysis presented in this report, Kimley-Horn believes Ovation will be successfully incorporated into the existing and future roadway network. Analysis of the existing street network, the proposed project development, and expected traffic volumes resulted in the following recommendations:

2025 Recommendations:

- The signal timings at the intersection of Old Ranch Road and Voyager Parkway (#1) may need to be optimized during the morning peak hour by increasing the green time for the eastbound and westbound approaches by eight (8) seconds and decreasing the green time for the northbound and southbound approaches by eight (8) seconds.
- The threshold for requiring an access permit along Colorado Department of Transportation (CDOT) roadways occurs when project traffic is anticipated to increase the existing access traffic volumes by more than 20 percent. Based on traffic projections, the addition of project traffic on the north leg at the Old Ranch Road and Powers Boulevard Southbound Ramp (#4) intersection are not anticipated to increase existing access traffic volumes by more than 20 percent during the afternoon peak hour. Therefore, an access permit is not anticipated to be needed at this intersection as development occurs.
- With completion of the Ovation project, access to the project will be provided by an extension of Chapel Ridge Drive to the north of the existing terminus, into the project property. Intersection analysis was provided for the first two intersections (#6 & #7) along this extension of Chapel Ridge Drive. It is recommended that a R1-1 “STOP” sign be installed on the eastbound and westbound approaches at the Chapel Ridge Drive North Access (#6) and a R1-1 “STOP” sign be installed on the westbound approach at the Chapel Ridge Drive South Access (#7). Additionally, it is recommended that Chapel Ridge Drive be restriped as a three-lane section with a two-way left turn lane.
- To improve pedestrian safety the City of Colorado Spring could explore the addition of crosswalks with rectangular rapid flashing beacons (RRFB) at the intersection of Rhinestone Drive and Chapel Ridge Drive, just to the south of the project site.

2045 Recommendations:

- The signal timings at the Old Ranch Road and Voyager Parkway (#1) may need to be optimized during the afternoon peak hour by increasing the green time for the southbound left turn movement by 10 seconds and the southbound through movement by 3.5 seconds and decreasing green time for the northbound left turn by three (3) seconds, the northbound through by 9.5 seconds, and the eastbound and westbound approaches by 0.5 seconds. Additionally, the signal timings at this intersection may need to be further optimized during the morning peak hour by increasing the green time for the eastbound and westbound approaches by two (2) seconds, increasing the green time for the northbound and southbound approaches by one (1) second, and decreasing the green time for the northbound and southbound left turn movements by three (3) seconds. If future project traffic volumes are realized by 2045, the southbound and westbound left turn lanes at this intersection may need to be extended to 325 feet. Additionally, the westbound right turn lane may need to be restriped as a continuous lane with City of Colorado Springs planned improvements along Old Ranch Road.
- The signal timings at the intersection of Old Ranch Road and Powers Boulevard Southbound Ramp (#4) may need to be optimized during the morning peak hour by increasing green time for the westbound left turn movement by six (6) seconds and westbound through movement by six (6) and decreasing green time for the southbound approach by six (6) seconds.
- The signal timings at the Old Ranch Road and Powers Boulevard Northbound Ramp (#5) intersection may need to be optimized during the morning peak hour by decreasing green time for the eastbound left turn movement by six (6) seconds, decreasing the green time for the eastbound through movement by 21 seconds, decreasing the green time for the westbound through movement by 15 seconds, and increasing green time for the northbound approach by 21 seconds.

General Recommendations:

- Any onsite or offsite improvements should be incorporated into the Civil Drawings and conform to standards of the City of Colorado Springs and the Manual on Uniform Traffic Control Devices (MUTCD) – 2009 Edition.

APPENDICES

APPENDIX A

Intersection Count Sheets

Location: 1 POWERS BLVD NB RAMP & OLD RANCH RD AM

Date: Thursday, March 16, 2023

Peak Hour: 07:15 AM - 08:15 AM

Peak 15-Minutes: 07:30 AM - 07:45 AM

Peak Hour - Motorized Vehicles

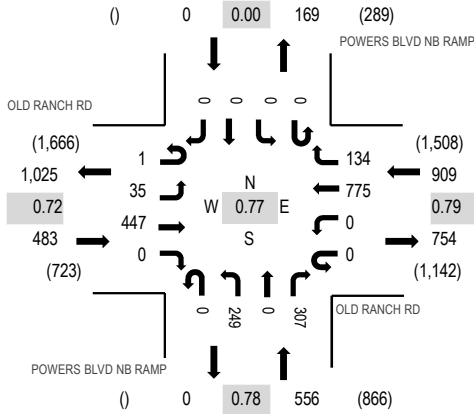

Peak Hour - Bicycles

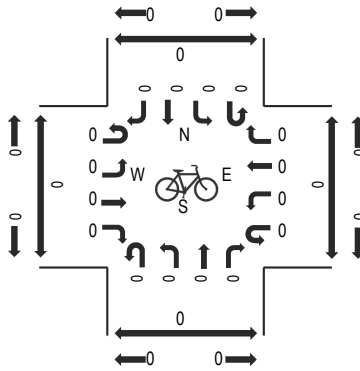

Peak Hour - Pedestrians

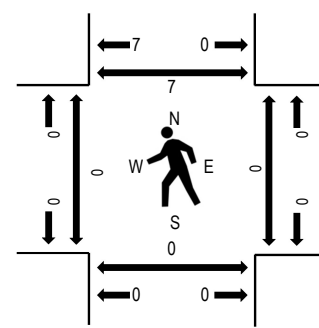

Note: Total study counts contained in parentheses.

Traffic Counts - Motorized Vehicles

Interval Start Time	OLD RANCH RD Eastbound				OLD RANCH RD Westbound				POWERS BLVD NB RAMP Northbound				POWERS BLVD NB RAMP Southbound				Total	Rolling Hour	Pedestrian Crossings			
	U-Turn	Left	Thru	Right	U-Turn	Left	Thru	Right	U-Turn	Left	Thru	Right	U-Turn	Left	Thru	Right			West	East	South	North
7:00 AM	0	1	57	0	0	0	129	25	0	32	0	67	0	0	0	0	311	1,944	0	0	0	0
7:15 AM	0	11	126	0	0	0	196	40	0	57	0	122	0	0	0	0	552	1,948	0	0	0	3
7:30 AM	0	12	156	0	0	0	253	39	0	70	0	99	0	0	0	0	629	1,768	0	0	0	4
7:45 AM	1	9	85	0	0	0	214	32	0	70	0	41	0	0	0	0	452	1,412	0	0	0	0
8:00 AM	0	3	80	0	0	0	112	23	0	52	0	45	0	0	0	0	315	1,153	0	0	0	0
8:15 AM	0	2	90	0	0	0	149	35	0	52	0	44	0	0	0	0	372		0	0	0	0
8:30 AM	0	6	45	0	0	0	126	25	0	40	0	31	0	0	0	0	273		0	0	0	0
8:45 AM	0	4	35	0	0	0	88	22	0	25	0	19	0	0	0	0	193		0	0	0	0
Count Total	1	48	674	0	0	0	1,267	241	0	398	0	468	0	0	0	0	3,097		0	0	0	7
Peak Hour	1	35	447	0	0	0	775	134	0	249	0	307	0	0	0	0	1,948		0	0	0	7

Location: 2 POWERS BLVD SB & OLD RANCH RD AM

Date: Thursday, March 16, 2023

Peak Hour: 07:15 AM - 08:15 AM

Peak 15-Minutes: 07:30 AM - 07:45 AM

Peak Hour - Motorized Vehicles

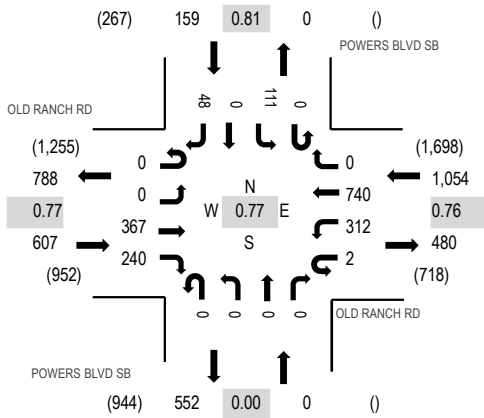

Peak Hour - Bicycles

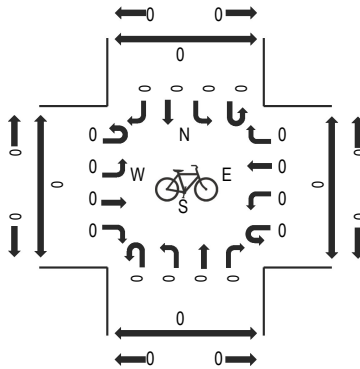

Peak Hour - Pedestrians

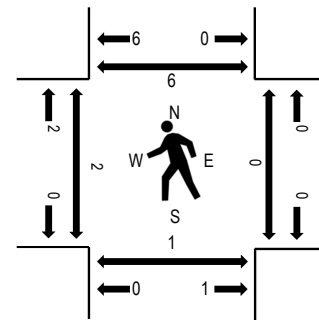

Note: Total study counts contained in parentheses.

Traffic Counts - Motorized Vehicles

Interval Start Time	OLD RANCH RD Eastbound				OLD RANCH RD Westbound				POWERS BLVD SB Northbound				POWERS BLVD SB Southbound				Total	Rolling Hour	Pedestrian Crossings				
	U-Turn	Left	Thru	Right	U-Turn	Left	Thru	Right	U-Turn	Left	Thru	Right	U-Turn	Left	Thru	Right			West	East	South	North	
7:00 AM	0	0	39	35	0	46	110	0	0	0	0	0	0	0	21	0	5	256	1,772	0	0	0	0
7:15 AM	0	0	107	45	0	82	172	0	0	0	0	0	0	0	31	0	7	444	1,820	2	0	1	3
7:30 AM	0	0	126	70	1	106	238	0	0	0	0	0	0	0	36	0	17	594	1,740	0	0	0	3
7:45 AM	0	0	79	77	1	83	209	0	0	0	0	0	0	0	15	0	14	478	1,441	0	0	0	0
8:00 AM	0	0	55	48	0	41	121	0	0	0	0	0	0	0	29	0	10	304	1,145	0	0	0	0
8:15 AM	0	0	56	52	0	75	130	0	0	0	0	0	0	0	34	0	17	364		0	0	0	0
8:30 AM	0	0	40	69	0	57	112	0	0	0	0	0	0	0	11	0	6	295		0	0	0	0
8:45 AM	0	0	30	24	0	34	80	0	0	0	0	0	0	0	7	0	7	182		0	0	0	0
Count Total	0	0	532	420	2	524	1,172	0	0	0	0	0	0	0	184	0	83	2,917		2	0	1	6
Peak Hour	0	0	367	240	2	312	740	0	0	0	0	0	0	0	111	0	48	1,820		2	0	1	6

Location: 3 CHAPEL HILLS DR & OLD RANCH RD AM

Date: Thursday, March 16, 2023

Peak Hour: 07:15 AM - 08:15 AM

Peak 15-Minutes: 07:30 AM - 07:45 AM

Peak Hour - Motorized Vehicles

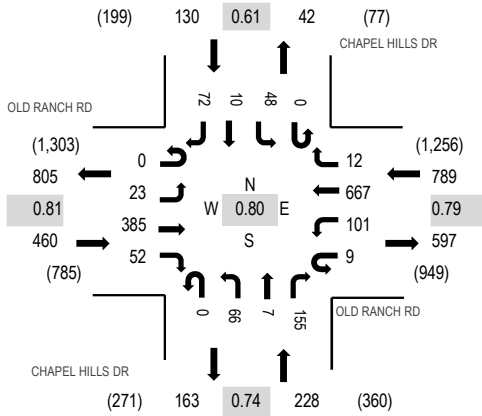

Peak Hour - Bicycles

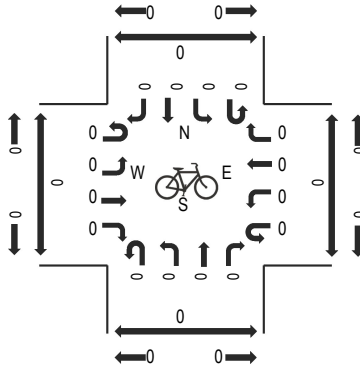

Peak Hour - Pedestrians

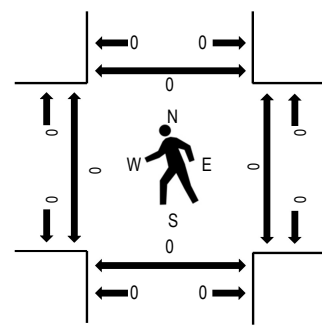

Note: Total study counts contained in parentheses.

Traffic Counts - Motorized Vehicles

Interval Start Time	OLD RANCH RD Eastbound				OLD RANCH RD Westbound				CHAPEL HILLS DR Northbound				CHAPEL HILLS DR Southbound				Total	Rolling Hour	Pedestrian Crossings			
	U-Turn	Left	Thru	Right	U-Turn	Left	Thru	Right	U-Turn	Left	Thru	Right	U-Turn	Left	Thru	Right			West	East	South	North
7:00 AM	0	1	47	2	1	13	107	1	0	11	0	23	0	10	2	10	228	1,563	0	0	0	0
7:15 AM	0	4	86	2	1	18	158	1	0	23	1	50	0	16	1	16	377	1,607	0	0	0	0
7:30 AM	0	2	103	14	4	34	207	4	0	18	2	61	0	24	8	24	505	1,537	0	0	0	0
7:45 AM	0	9	112	27	3	28	195	2	0	17	3	32	0	5	1	19	453	1,324	0	0	0	0
8:00 AM	0	8	84	9	1	21	107	5	0	8	1	12	0	3	0	13	272	1,037	0	0	0	0
8:15 AM	0	8	74	15	3	17	127	2	0	16	3	20	0	7	1	14	307		0	0	0	0
8:30 AM	0	12	94	29	0	14	103	0	0	11	1	14	0	3	0	11	292		0	0	0	0
8:45 AM	0	3	34	6	1	9	67	2	0	15	2	16	0	5	0	6	166		0	0	0	0
Count Total	0	47	634	104	14	154	1,071	17	0	119	13	228	0	73	13	113	2,600		0	0	0	0
Peak Hour	0	23	385	52	9	101	667	12	0	66	7	155	0	48	10	72	1,607		0	0	0	0

Location: 4 LEXINGTON DR & OLD RANCH RD AM

Date: Thursday, March 16, 2023

Peak Hour: 07:30 AM - 08:30 AM

Peak 15-Minutes: 07:30 AM - 07:45 AM

Peak Hour - Motorized Vehicles

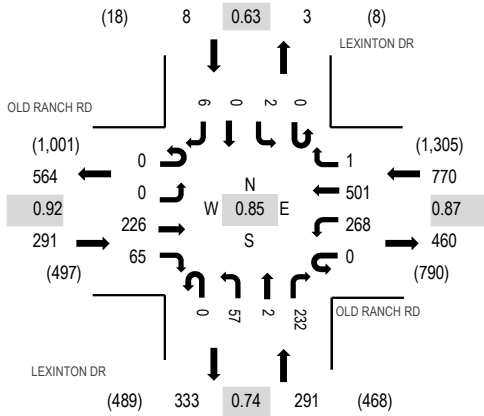

Peak Hour - Bicycles

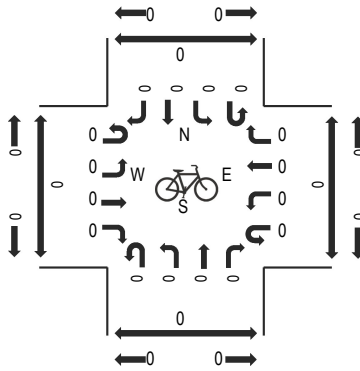

Peak Hour - Pedestrians

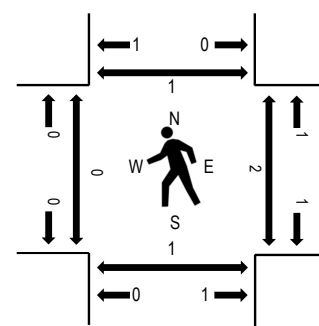

Note: Total study counts contained in parentheses.

Traffic Counts - Motorized Vehicles

Interval Start Time	OLD RANCH RD Eastbound				OLD RANCH RD Westbound				LEXINGTON DR Northbound				LEXINGTON DR Southbound				Total	Rolling Hour	Pedestrian Crossings			
	U-Turn	Left	Thru	Right	U-Turn	Left	Thru	Right	U-Turn	Left	Thru	Right	U-Turn	Left	Thru	Right			West	East	South	North
7:00 AM	0	0	35	2	0	27	117	1	0	2	0	27	0	0	0	1	212	1,286	0	0	0	0
7:15 AM	0	0	67	10	0	67	119	0	0	4	1	32	0	2	0	1	303	1,324	0	0	3	1
7:30 AM	0	0	60	16	0	104	117	0	0	16	1	80	0	1	0	3	398	1,360	0	1	1	1
7:45 AM	0	0	58	10	0	61	144	0	0	23	1	74	0	1	0	1	373	1,238	0	0	0	0
8:00 AM	0	0	58	10	0	35	124	1	0	5	0	16	0	0	0	1	250	1,002	0	1	0	0
8:15 AM	0	0	50	29	0	68	116	0	0	13	0	62	0	0	0	1	339		0	0	0	0
8:30 AM	0	0	47	8	0	23	96	1	0	17	1	80	0	0	1	2	276		0	0	0	0
8:45 AM	0	1	29	7	0	10	74	0	0	3	0	10	0	1	1	1	137		0	0	0	0
Count Total	0	1	404	92	0	395	907	3	0	83	4	381	0	5	2	11	2,288		0	2	4	2
Peak Hour	0	0	226	65	0	268	501	1	0	57	2	232	0	2	0	6	1,360		0	2	1	1

Location: 5 VOYAGER PKWY & OLD RANCH RD AM

Date: Thursday, March 16, 2023

Peak Hour: 07:30 AM - 08:30 AM

Peak 15-Minutes: 07:45 AM - 08:00 AM

Peak Hour - Motorized Vehicles

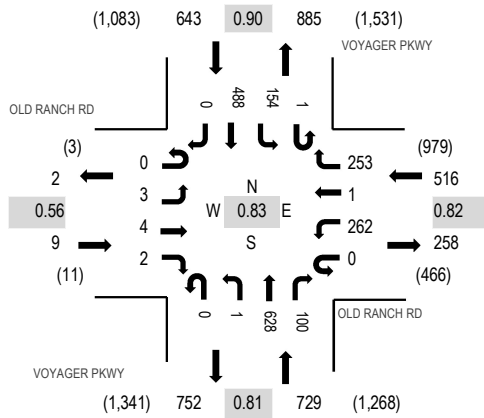

Peak Hour - Bicycles

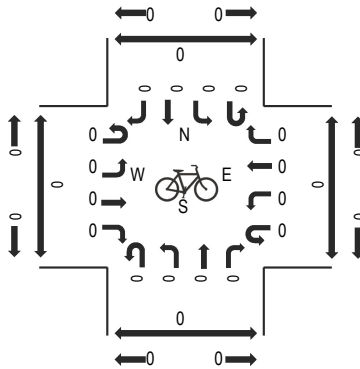

Peak Hour - Pedestrians

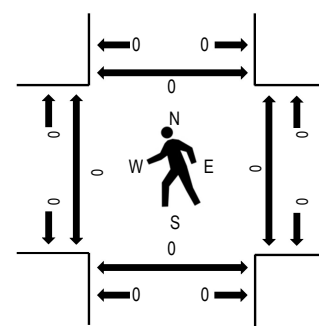

Note: Total study counts contained in parentheses.

Traffic Counts - Motorized Vehicles

Interval Start Time	OLD RANCH RD Eastbound				OLD RANCH RD Westbound				VOYAGER PKWY Northbound				VOYAGER PKWY Southbound				Total	Rolling Hour	Pedestrian Crossings			
	U-Turn	Left	Thru	Right	U-Turn	Left	Thru	Right	U-Turn	Left	Thru	Right	U-Turn	Left	Thru	Right			West	East	South	North
7:00 AM	0	0	0	1	0	59	0	47	0	0	80	34	0	25	64	0	310	1,748	0	0	0	0
7:15 AM	0	0	1	0	0	90	0	69	0	0	130	30	0	30	79	0	429	1,889	0	0	0	0
7:30 AM	0	0	1	0	0	78	0	62	0	0	154	20	0	25	97	0	437	1,897	0	0	0	0
7:45 AM	0	0	0	2	0	75	0	102	0	0	197	30	1	34	131	0	572	1,841	0	0	0	0
8:00 AM	0	2	2	0	0	52	0	39	0	1	153	19	0	50	133	0	451	1,593	0	0	0	0
8:15 AM	0	1	1	0	0	57	1	50	0	0	124	31	0	45	127	0	437		0	0	0	0
8:30 AM	0	0	0	0	0	62	0	54	0	0	111	18	0	33	103	0	381		0	0	0	0
8:45 AM	0	0	0	0	0	41	0	41	0	0	114	22	0	15	90	1	324		0	0	0	0
Count Total	0	3	5	3	0	514	1	464	0	1	1,063	204	1	257	824	1	3,341		0	0	0	0
Peak Hour	0	3	4	2	0	262	1	253	0	1	628	100	1	154	488	0	1,897		0	0	0	0

Location: 1 POWERS BLVD NB RAMP & OLD RANCH RD PM

Date: Thursday, March 16, 2023

Peak Hour: 04:30 PM - 05:30 PM

Peak 15-Minutes: 05:00 PM - 05:15 PM

Peak Hour - Motorized Vehicles

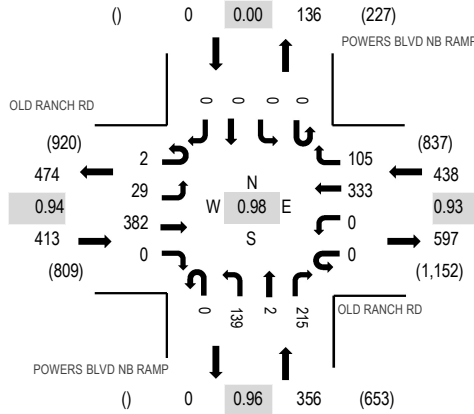

Peak Hour - Bicycles

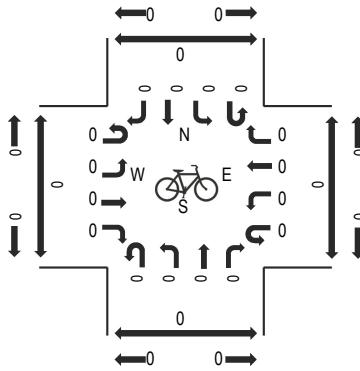

Peak Hour - Pedestrians

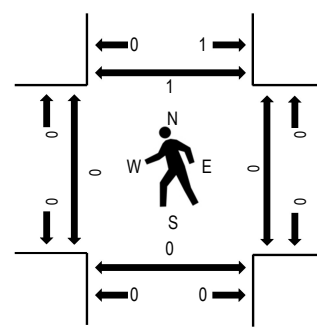

Note: Total study counts contained in parentheses.

Traffic Counts - Motorized Vehicles

Interval Start Time	OLD RANCH RD Eastbound				OLD RANCH RD Westbound				POWERS BLVD NB RAMP Northbound				POWERS BLVD NB RAMP Southbound				Total	Rolling Hour	Pedestrian Crossings			
	U-Turn	Left	Thru	Right	U-Turn	Left	Thru	Right	U-Turn	Left	Thru	Right	U-Turn	Left	Thru	Right			West	East	South	North
4:00 PM	0	5	97	0	0	0	100	27	0	32	0	31	0	0	0	0	292	1,177	0	0	0	2
4:15 PM	0	5	86	0	0	0	99	16	0	37	0	44	0	0	0	0	287	1,192	0	0	0	0
4:30 PM	1	7	89	0	0	0	95	22	0	32	2	56	0	0	0	0	304	1,207	0	0	0	1
4:45 PM	1	8	86	0	0	0	76	38	0	36	0	49	0	0	0	0	294	1,166	0	0	0	0
5:00 PM	0	4	104	0	0	0	84	27	0	35	0	53	0	0	0	0	307	1,122	0	0	0	0
5:15 PM	0	10	103	0	0	0	78	18	0	36	0	57	0	0	0	0	302		0	0	0	0
5:30 PM	0	3	87	0	0	0	69	19	0	30	0	55	0	0	0	0	263		0	0	0	0
5:45 PM	0	6	107	0	0	0	59	10	0	20	0	48	0	0	0	0	250		0	0	0	0
Count Total	2	48	759	0	0	0	660	177	0	258	2	393	0	0	0	0	2,299		0	0	0	3
Peak Hour	2	29	382	0	0	0	333	105	0	139	2	215	0	0	0	0	1,207		0	0	0	1

Location: 2 POWERS BLVD SB & OLD RANCH RD PM

Date: Thursday, March 16, 2023

Peak Hour: 04:00 PM - 05:00 PM

Peak 15-Minutes: 04:00 PM - 04:15 PM

Peak Hour - Motorized Vehicles

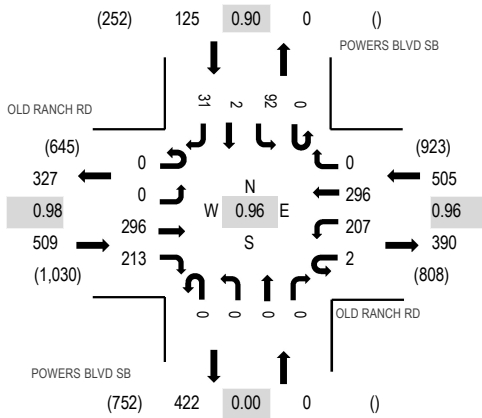

Peak Hour - Bicycles

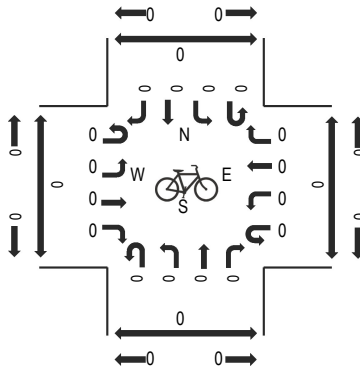

Peak Hour - Pedestrians

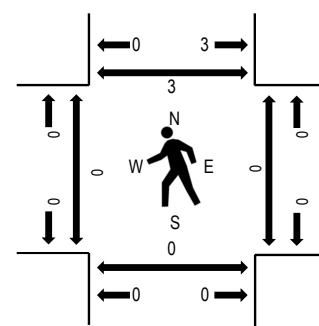

Note: Total study counts contained in parentheses.

Traffic Counts - Motorized Vehicles

Interval Start Time	OLD RANCH RD Eastbound				OLD RANCH RD Westbound				POWERS BLVD SB Northbound				POWERS BLVD SB Southbound				Total	Rolling Hour	Pedestrian Crossings				
	U-Turn	Left	Thru	Right	U-Turn	Left	Thru	Right	U-Turn	Left	Thru	Right	U-Turn	Left	Thru	Right			West	East	South	North	
4:00 PM	0	0	83	54	1	55	76	0	0	0	0	0	0	0	21	1	6	297	1,139	0	0	0	2
4:15 PM	0	0	63	52	0	47	84	0	0	0	0	0	0	0	23	0	11	280	1,131	0	0	0	0
4:30 PM	0	0	77	51	1	52	78	0	0	0	0	0	0	0	22	0	10	291	1,129	0	0	0	1
4:45 PM	0	0	73	56	0	53	58	0	0	0	0	0	0	0	26	1	4	271	1,090	0	0	0	0
5:00 PM	0	0	81	52	0	40	83	0	0	0	0	0	0	0	24	0	9	289	1,066	0	0	0	0
5:15 PM	0	0	78	50	0	33	80	0	0	0	0	0	0	0	32	0	5	278		0	0	0	0
5:30 PM	0	0	75	52	0	31	69	0	0	0	0	0	0	0	17	0	8	252		0	0	0	0
5:45 PM	0	0	90	43	0	28	54	0	0	0	0	0	0	0	21	1	10	247		0	0	0	0
Count Total	0	0	620	410	2	339	582	0	0	0	0	0	0	0	186	3	63	2,205		0	0	0	3
Peak Hour	0	0	296	213	2	207	296	0	0	0	0	0	0	0	92	2	31	1,139		0	0	0	3

Location: 3 CHAPEL HILLS DR & OLD RANCH RD PM

Date: Thursday, March 16, 2023

Peak Hour: 04:30 PM - 05:30 PM

Peak 15-Minutes: 04:30 PM - 04:45 PM

Peak Hour - Motorized Vehicles

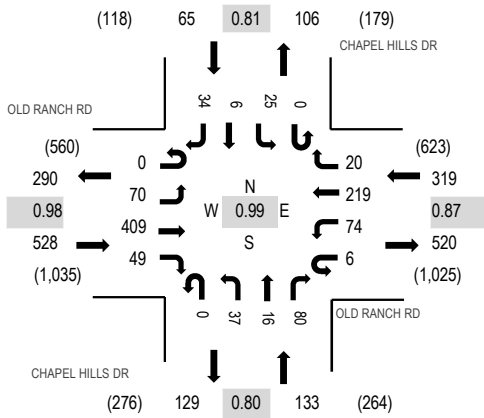

Peak Hour - Bicycles

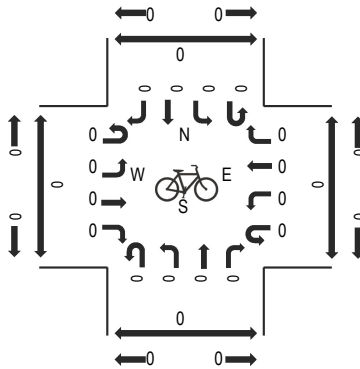

Peak Hour - Pedestrians

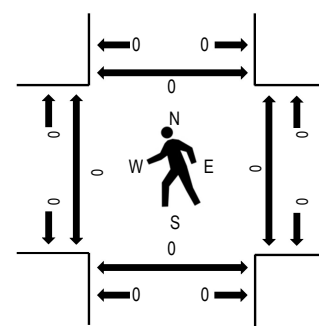

Note: Total study counts contained in parentheses.

Traffic Counts - Motorized Vehicles

Interval Start Time	OLD RANCH RD Eastbound				OLD RANCH RD Westbound				CHAPEL HILLS DR Northbound				CHAPEL HILLS DR Southbound				Total	Rolling Hour	Pedestrian Crossings			
	U-Turn	Left	Thru	Right	U-Turn	Left	Thru	Right	U-Turn	Left	Thru	Right	U-Turn	Left	Thru	Right			West	East	South	North
4:00 PM	0	11	104	14	3	14	50	3	0	6	3	22	0	1	0	4	235	1,008	2	0	0	0
4:15 PM	0	9	87	15	3	24	65	2	1	6	5	23	0	4	2	8	254	1,036	0	0	0	0
4:30 PM	0	16	102	11	1	21	56	7	0	15	3	17	0	6	2	7	264	1,045	0	0	0	0
4:45 PM	0	22	90	15	1	12	46	3	0	9	4	33	0	8	1	11	255	1,031	0	0	0	0
5:00 PM	0	12	111	11	0	23	59	5	0	10	5	13	0	7	1	6	263	1,032	0	0	0	0
5:15 PM	0	20	106	12	4	18	58	5	0	3	4	17	0	4	2	10	263		0	0	0	0
5:30 PM	1	14	98	21	2	15	55	2	0	7	2	20	0	4	0	9	250		0	0	0	0
5:45 PM	0	16	99	18	2	20	42	2	0	7	4	25	0	8	3	10	256		1	0	0	0
Count Total	1	120	797	117	16	147	431	29	1	63	30	170	0	42	11	65	2,040		3	0	0	0
Peak Hour	0	70	409	49	6	74	219	20	0	37	16	80	0	25	6	34	1,045		0	0	0	0

Location: 4 LEXINGTON DR & OLD RANCH RD PM

Date: Thursday, March 16, 2023

Peak Hour: 04:00 PM - 05:00 PM

Peak 15-Minutes: 04:15 PM - 04:30 PM

Peak Hour - Motorized Vehicles

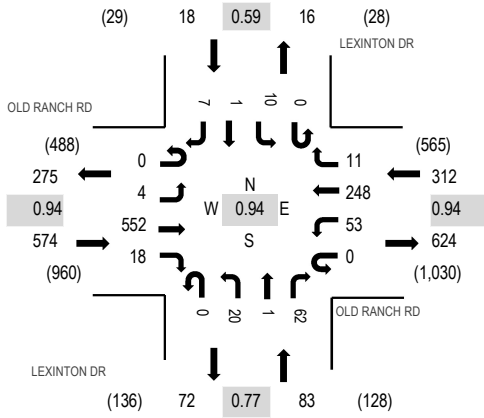

Peak Hour - Bicycles

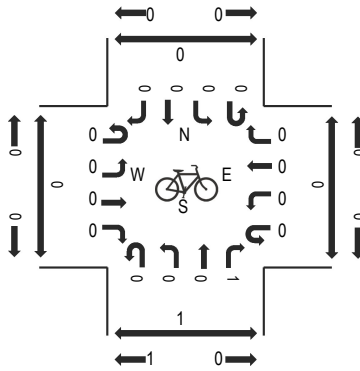

Peak Hour - Pedestrians

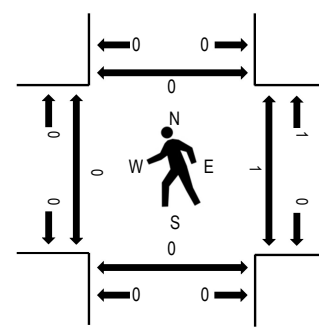

Note: Total study counts contained in parentheses.

Traffic Counts - Motorized Vehicles

Interval Start Time	OLD RANCH RD Eastbound				OLD RANCH RD Westbound				LEXINGTON DR Northbound				LEXINGTON DR Southbound				Total	Rolling Hour	Pedestrian Crossings			
	U-Turn	Left	Thru	Right	U-Turn	Left	Thru	Right	U-Turn	Left	Thru	Right	U-Turn	Left	Thru	Right			West	East	South	North
4:00 PM	0	1	144	5	0	18	43	5	0	1	0	19	0	1	0	1	238	987	0	0	0	0
4:15 PM	0	0	143	5	0	14	65	3	0	6	1	20	0	2	1	2	262	940	0	1	0	0
4:30 PM	0	1	146	6	0	5	73	2	0	7	0	11	0	6	0	2	259	855	0	0	0	0
4:45 PM	0	2	119	2	0	16	67	1	0	6	0	12	0	1	0	2	228	754	0	0	0	0
5:00 PM	0	1	102	3	0	7	58	4	0	5	0	8	0	2	1	0	191	695	0	0	0	0
5:15 PM	0	0	98	3	0	6	56	1	0	2	0	10	0	0	0	1	177		0	0	0	0
5:30 PM	0	1	82	5	1	5	49	2	0	3	0	7	0	2	1	0	158		0	0	0	0
5:45 PM	0	1	82	8	0	25	37	2	0	2	0	8	0	4	0	0	169		0	0	0	0
Count Total	0	7	916	37	1	96	448	20	0	32	1	95	0	18	3	8	1,682		0	1	0	0
Peak Hour	0	4	552	18	0	53	248	11	0	20	1	62	0	10	1	7	987		0	1	0	0

Location: 5 VOYAGER PKWY & OLD RANCH RD PM

Date: Thursday, March 16, 2023

Peak Hour: 04:45 PM - 05:45 PM

Peak 15-Minutes: 05:15 PM - 05:30 PM

Peak Hour - Motorized Vehicles

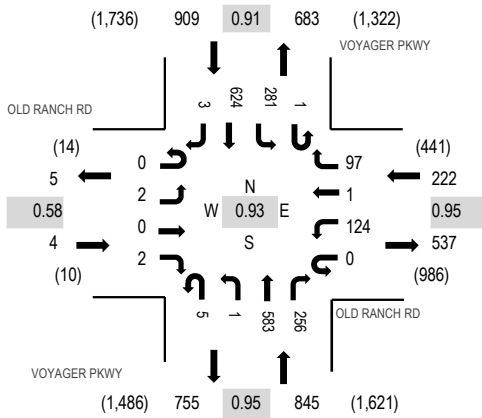

Peak Hour - Bicycles

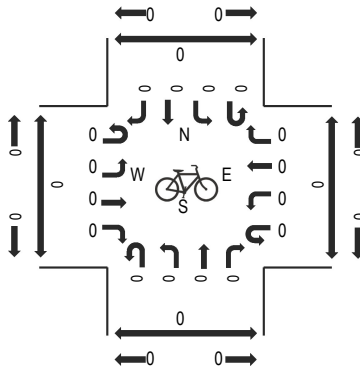

Peak Hour - Pedestrians

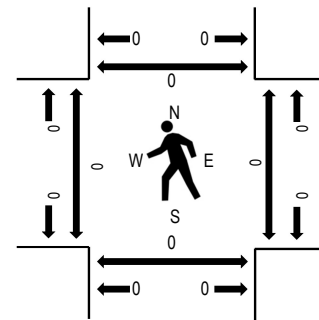

Note: Total study counts contained in parentheses.

Traffic Counts - Motorized Vehicles

Interval Start Time	OLD RANCH RD Eastbound				OLD RANCH RD Westbound				VOYAGER PKWY Northbound				VOYAGER PKWY Southbound				Total	Rolling Hour	Pedestrian Crossings			
	U-Turn	Left	Thru	Right	U-Turn	Left	Thru	Right	U-Turn	Left	Thru	Right	U-Turn	Left	Thru	Right			West	East	South	North
4:00 PM	0	2	1	0	0	32	0	22	4	1	141	47	1	60	149	0	460	1,845	0	0	0	0
4:15 PM	0	0	1	1	0	25	1	23	3	3	125	42	0	66	175	0	465	1,879	0	0	0	0
4:30 PM	0	0	0	0	0	33	1	26	2	2	121	51	0	59	161	1	457	1,949	0	0	0	0
4:45 PM	0	2	0	0	0	33	1	23	3	0	141	44	0	64	152	0	463	1,980	0	0	0	0
5:00 PM	0	0	0	0	0	26	0	27	1	0	154	61	0	70	154	1	494	1,963	0	0	0	0
5:15 PM	0	0	0	2	0	31	0	28	1	0	148	74	0	67	183	1	535		0	0	0	0
5:30 PM	0	0	0	0	0	34	0	19	0	1	140	77	1	80	135	1	488		0	0	0	0
5:45 PM	0	1	0	0	0	37	0	19	2	0	158	74	0	48	107	0	446		0	0	0	0
Count Total	0	5	2	3	0	251	3	187	16	7	1,128	470	2	514	1,216	4	3,808		0	0	0	0
Peak Hour	0	2	0	2	0	124	1	97	5	1	583	256	1	281	624	3	1,980		0	0	0	0

APPENDIX B

Future Traffic Projections

ROUTE	REFPT	ENDREFPT	LENGTH	AADT	AADTYR	YR20FACT	GROWTH RATE	DHV	LOCATION
021B	151.646	154.112	2.524	41000	2021	1.36	1.5%	9.5	ON SH 21 POWERS BLVD 0.6 MI S/O OLD RANCH RD COLO SPGS

APPENDIX C

Trip Generation Worksheets

Project Larry Ochs Property
 Subject Trip Generation for Single-Family Detached Housing
 Designed by TES Date September 06, 2023 Job No. 096849003
 Checked by _____ Date _____ Sheet No. _____ of _____

TRIP GENERATION MANUAL TECHNIQUES

ITE Trip Generation Manual 11th Edition, Fitted Curve Equations

Land Use Code - Single-Family Detached Housing (210)

Independent Variable - Dwelling Units (X)

X = 360
 T = Average Vehicle Trip Ends

Peak Hour of Adjacent Street Traffic, One Hour Between 7 and 9 a.m. (200 Series Page 220)

$\ln(T) = 0.91 \ln(X) + 0.12$ $\ln(T) = 0.91 * \ln(360) + 0.12$	Directional Distribution: 26% ent. 74% exit. T = 238 Average Vehicle Trip Ends 62 entering 176 exiting 62 + 176 = 238
---	--

Peak Hour of Adjacent Street Traffic, One Hour Between 4 and 6 p.m. (200 Series Page 221)

$\ln(T) = 0.94 \ln(X) + 0.27$ $\ln(T) = 0.94 * \ln(360) + 0.27$	Directional Distribution: 63% ent. 37% exit. T = 331 Average Vehicle Trip Ends 209 entering 122 exiting 209 + 122 = 331
---	--

Weekday (200 Series Page 219)

$\ln(T) = 0.92 \ln(X) + 2.68$ $\ln(T) = 0.92 * \ln(360) + 2.68$	Directional Distribution: 50% entering, 50% exiting T = 3278 Average Vehicle Trip Ends 1639 entering 1639 exiting 1639 + 1639 = 3278
---	---

APPENDIX D

Intersection Analysis Worksheets

Timings
1: Voyager Pkwy & Old Ranch Rd

2023 Existing AM
09/06/2023



Lane Group	EBL	EBT	WBL	WBT	WBR	NBL	NBT	NBR	SBL	SBT
Lane Configurations	↖	↗	↖	↗	↗	↖	↑↑	↗	↖	↑↑
Traffic Volume (vph)	3	4	262	1	253	1	628	100	155	488
Future Volume (vph)	3	4	262	1	253	1	628	100	155	488
Turn Type	Perm	NA	Perm	NA	Perm	pm+pt	NA	Perm	pm+pt	NA
Protected Phases		4		8		5	2		1	6
Permitted Phases	4		8		8	2		2	6	
Detector Phase	4	4	8	8	8	5	2	2	1	6
Switch Phase										
Minimum Initial (s)	4.0	4.0	4.0	4.0	4.0	4.0	23.0	23.0	4.0	23.0
Minimum Split (s)	24.5	24.5	24.5	24.5	24.5	10.0	30.5	30.5	10.0	30.5
Total Split (s)	25.0	25.0	25.0	25.0	25.0	13.0	31.0	31.0	13.0	31.0
Total Split (%)	36.2%	36.2%	36.2%	36.2%	36.2%	18.8%	44.9%	44.9%	18.8%	44.9%
Yellow Time (s)	4.5	4.5	4.5	4.5	4.5	3.0	5.5	5.5	3.0	5.5
All-Red Time (s)	2.0	2.0	2.0	2.0	2.0	2.0	2.0	2.0	2.0	2.0
Lost Time Adjust (s)	0.0	0.0	0.0	0.0	0.0	0.0	0.0	0.0	0.0	0.0
Total Lost Time (s)	6.5	6.5	6.5	6.5	6.5	5.0	7.5	7.5	5.0	7.5
Lead/Lag						Lead	Lag	Lag	Lead	Lag
Lead-Lag Optimize?						Yes	Yes	Yes	Yes	Yes
Recall Mode	None	None	None	None	None	None	C-Max	C-Max	None	C-Max
Act Effct Green (s)	17.7	17.7	17.7	17.7	17.7	32.7	24.6	24.6	39.3	35.2
Actuated g/C Ratio	0.26	0.26	0.26	0.26	0.26	0.47	0.36	0.36	0.57	0.51
v/c Ratio	0.01	0.02	0.88	0.00	0.48	0.00	0.60	0.18	0.47	0.33
Control Delay	18.7	16.7	51.8	19.0	5.7	7.0	21.0	3.6	11.3	11.6
Queue Delay	0.0	0.0	0.0	0.0	0.0	0.0	0.0	0.0	0.0	0.0
Total Delay	18.7	16.7	51.8	19.0	5.7	7.0	21.0	3.6	11.3	11.6
LOS	B	B	D	B	A	A	C	A	B	B
Approach Delay		17.4		29.1			18.6			11.6
Approach LOS		B		C			B			B

Intersection Summary

Cycle Length: 69
 Actuated Cycle Length: 69
 Offset: 26 (38%), Referenced to phase 2:NBTL and 6:SBTL, Start of Green
 Natural Cycle: 65
 Control Type: Actuated-Coordinated
 Maximum v/c Ratio: 0.88
 Intersection Signal Delay: 19.1
 Intersection Capacity Utilization 64.8%
 Analysis Period (min) 15

Intersection LOS: B
 ICU Level of Service C

Splits and Phases: 1: Voyager Pkwy & Old Ranch Rd

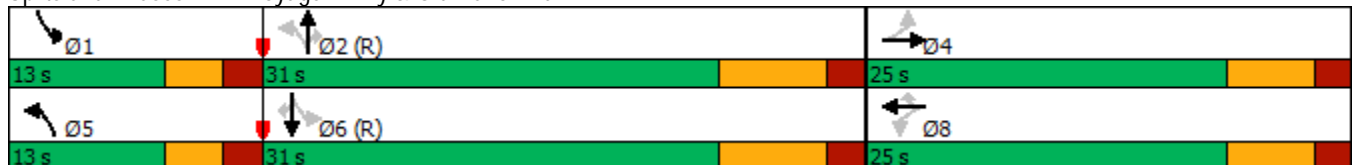

HCM 6th Signalized Intersection Summary
1: Voyager Pkwy & Old Ranch Rd

2023 Existing AM

09/06/2023

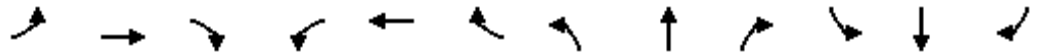

Movement	EBL	EBT	EBR	WBL	WBT	WBR	NBL	NBT	NBR	SBL	SBT	SBR
Lane Configurations												
Traffic Volume (veh/h)	3	4	2	262	1	253	1	628	100	155	488	0
Future Volume (veh/h)	3	4	2	262	1	253	1	628	100	155	488	0
Initial Q (Qb), veh	0	0	0	0	0	0	0	0	0	0	0	0
Ped-Bike Adj(A_pbT)	1.00		1.00	1.00		1.00	1.00		1.00	1.00		1.00
Parking Bus, Adj	1.00	1.00	1.00	1.00	1.00	1.00	1.00	1.00	1.00	1.00	1.00	1.00
Work Zone On Approach		No			No			No			No	
Adj Sat Flow, veh/h/ln	1870	1870	1870	1870	1870	1870	1870	1870	1870	1870	1870	1870
Adj Flow Rate, veh/h	4	5	2	316	1	305	1	757	120	187	588	0
Peak Hour Factor	0.83	0.83	0.83	0.83	0.83	0.83	0.83	0.83	0.83	0.83	0.83	0.83
Percent Heavy Veh, %	2	2	2	2	2	2	2	2	2	2	2	2
Cap, veh/h	376	323	129	458	475	402	409	1365	609	396	1669	745
Arrive On Green	0.25	0.25	0.25	0.25	0.25	0.25	0.00	0.38	0.38	0.09	0.47	0.00
Sat Flow, veh/h	1073	1271	508	1409	1870	1585	1781	3554	1585	1781	3554	1585
Grp Volume(v), veh/h	4	0	7	316	1	305	1	757	120	187	588	0
Grp Sat Flow(s),veh/h/ln	1073	0	1779	1409	1870	1585	1781	1777	1585	1781	1777	1585
Q Serve(g_s), s	0.2	0.0	0.2	14.9	0.0	12.3	0.0	11.5	3.5	4.0	7.3	0.0
Cycle Q Clear(g_c), s	0.2	0.0	0.2	15.2	0.0	12.3	0.0	11.5	3.5	4.0	7.3	0.0
Prop In Lane	1.00		0.29	1.00		1.00	1.00		1.00	1.00		1.00
Lane Grp Cap(c), veh/h	376	0	452	458	475	402	409	1365	609	396	1669	745
V/C Ratio(X)	0.01	0.00	0.02	0.69	0.00	0.76	0.00	0.55	0.20	0.47	0.35	0.00
Avail Cap(c_a), veh/h	392	0	477	478	501	425	613	1365	609	448	1669	745
HCM Platoon Ratio	1.00	1.00	1.00	1.00	1.00	1.00	1.00	1.00	1.00	1.00	1.00	1.00
Upstream Filter(l)	1.00	0.00	1.00	1.00	1.00	1.00	1.00	1.00	1.00	1.00	1.00	0.00
Uniform Delay (d), s/veh	19.3	0.0	19.3	25.0	19.2	23.8	13.0	16.6	14.2	11.5	11.6	0.0
Incr Delay (d2), s/veh	0.0	0.0	0.0	4.0	0.0	7.3	0.0	1.6	0.7	0.9	0.6	0.0
Initial Q Delay(d3),s/veh	0.0	0.0	0.0	0.0	0.0	0.0	0.0	0.0	0.0	0.0	0.0	0.0
%ile BackOfQ(50%),veh/ln	0.0	0.0	0.1	5.2	0.0	5.1	0.0	4.6	1.3	1.5	2.7	0.0
Unsig. Movement Delay, s/veh												
LnGrp Delay(d),s/veh	19.3	0.0	19.3	29.0	19.2	31.1	13.0	18.2	14.9	12.4	12.2	0.0
LnGrp LOS	B	A	B	C	B	C	B	B	B	B	B	A
Approach Vol, veh/h		11			622			878			775	
Approach Delay, s/veh		19.3			30.0			17.8			12.3	
Approach LOS		B			C			B			B	
Timer - Assigned Phs	1	2		4	5	6		8				
Phs Duration (G+Y+Rc), s	11.0	34.0		24.0	5.1	39.9		24.0				
Change Period (Y+Rc), s	5.0	7.5		6.5	5.0	7.5		6.5				
Max Green Setting (Gmax), s	8.0	23.5		18.5	8.0	23.5		18.5				
Max Q Clear Time (g_c+I1), s	6.0	13.5		2.2	2.0	9.3		17.2				
Green Ext Time (p_c), s	0.1	4.0		0.0	0.0	3.4		0.4				

Intersection Summary

HCM 6th Ctrl Delay	19.2
HCM 6th LOS	B

Timings
1: Voyager Pkwy & Old Ranch Rd

2023 Existing PM
09/06/2023



Lane Group	EBL	EBT	WBL	WBT	WBR	NBL	NBT	NBR	SBL	SBT	SBR
Lane Configurations	↖	↗	↖	↗	↗	↖	↕	↗	↖	↕	↗
Traffic Volume (vph)	2	0	124	1	97	6	583	256	282	624	3
Future Volume (vph)	2	0	124	1	97	6	583	256	282	624	3
Turn Type	Perm	NA	Perm	NA	Perm	pm+pt	NA	Perm	pm+pt	NA	Perm
Protected Phases		4		8		5	2		1	6	
Permitted Phases	4		8		8	2		2	6		6
Detector Phase	4	4	8	8	8	5	2	2	1	6	6
Switch Phase											
Minimum Initial (s)	4.0	4.0	4.0	4.0	4.0	4.0	23.0	23.0	4.0	23.0	23.0
Minimum Split (s)	24.5	24.5	24.5	24.5	24.5	10.0	30.5	30.5	10.0	30.5	30.5
Total Split (s)	25.0	25.0	25.0	25.0	25.0	13.0	31.0	31.0	13.0	31.0	31.0
Total Split (%)	36.2%	36.2%	36.2%	36.2%	36.2%	18.8%	44.9%	44.9%	18.8%	44.9%	44.9%
Yellow Time (s)	4.5	4.5	4.5	4.5	4.5	3.0	5.5	5.5	3.0	5.5	5.5
All-Red Time (s)	2.0	2.0	2.0	2.0	2.0	2.0	2.0	2.0	2.0	2.0	2.0
Lost Time Adjust (s)	0.0	0.0	0.0	0.0	0.0	0.0	0.0	0.0	0.0	0.0	0.0
Total Lost Time (s)	6.5	6.5	6.5	6.5	6.5	5.0	7.5	7.5	5.0	7.5	7.5
Lead/Lag						Lead	Lag	Lag	Lead	Lag	Lag
Lead-Lag Optimize?						Yes	Yes	Yes	Yes	Yes	Yes
Recall Mode	None	None	None	None	None	None	C-Max	C-Max	None	C-Max	C-Max
Act Effct Green (s)	11.5	11.5	11.8	11.8	11.8	39.6	31.5	31.5	48.1	45.2	45.2
Actuated g/C Ratio	0.17	0.17	0.17	0.17	0.17	0.57	0.46	0.46	0.70	0.66	0.66
v/c Ratio	0.01	0.00	0.55	0.00	0.26	0.01	0.39	0.32	0.51	0.29	0.00
Control Delay	21.0	0.0	34.2	21.0	3.5	6.0	15.7	3.6	8.5	8.6	0.0
Queue Delay	0.0	0.0	0.0	0.0	0.0	0.0	0.0	0.0	0.0	0.0	0.0
Total Delay	21.0	0.0	34.2	21.0	3.5	6.0	15.7	3.6	8.5	8.6	0.0
LOS	C	A	C	C	A	A	B	A	A	A	A
Approach Delay		10.5		20.7			12.0			8.5	
Approach LOS		B		C			B			A	

Intersection Summary

Cycle Length: 69
 Actuated Cycle Length: 69
 Offset: 26 (38%), Referenced to phase 2:NBTL and 6:SBTL, Start of Green
 Natural Cycle: 65
 Control Type: Actuated-Coordinated
 Maximum v/c Ratio: 0.55
 Intersection Signal Delay: 11.4
 Intersection Capacity Utilization 64.2%
 Analysis Period (min) 15
 Intersection LOS: B
 ICU Level of Service C

Splits and Phases: 1: Voyager Pkwy & Old Ranch Rd

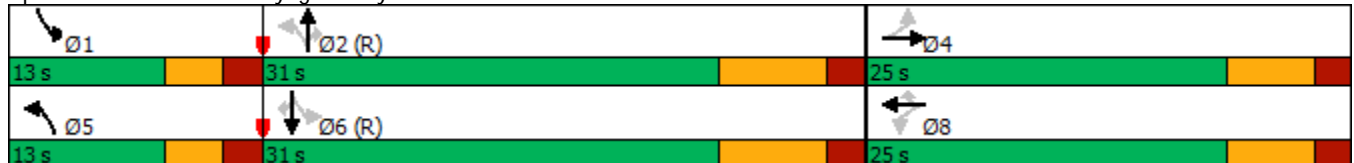

HCM 6th Signalized Intersection Summary
1: Voyager Pkwy & Old Ranch Rd

2023 Existing PM
09/06/2023



Movement	EBL	EBT	EBR	WBL	WBT	WBR	NBL	NBT	NBR	SBL	SBT	SBR
Lane Configurations												
Traffic Volume (veh/h)	2	0	2	124	1	97	6	583	256	282	624	3
Future Volume (veh/h)	2	0	2	124	1	97	6	583	256	282	624	3
Initial Q (Qb), veh	0	0	0	0	0	0	0	0	0	0	0	0
Ped-Bike Adj(A_pbT)	1.00		1.00	1.00		1.00	1.00		1.00	1.00		1.00
Parking Bus, Adj	1.00	1.00	1.00	1.00	1.00	1.00	1.00	1.00	1.00	1.00	1.00	1.00
Work Zone On Approach		No			No			No			No	
Adj Sat Flow, veh/h/ln	1870	1870	1870	1870	1870	1870	1870	1870	1870	1870	1870	1870
Adj Flow Rate, veh/h	2	0	2	133	1	104	6	627	275	303	671	3
Peak Hour Factor	0.93	0.93	0.93	0.93	0.93	0.93	0.93	0.93	0.93	0.93	0.93	0.93
Percent Heavy Veh, %	2	2	2	2	2	2	2	2	2	2	2	2
Cap, veh/h	267	0	201	282	237	201	491	1747	779	530	2103	938
Arrive On Green	0.13	0.00	0.13	0.13	0.13	0.13	0.01	0.49	0.49	0.11	0.59	0.59
Sat Flow, veh/h	1289	0	1585	1415	1870	1585	1781	3554	1585	1781	3554	1585
Grp Volume(v), veh/h	2	0	2	133	1	104	6	627	275	303	671	3
Grp Sat Flow(s),veh/h/ln	1289	0	1585	1415	1870	1585	1781	1777	1585	1781	1777	1585
Q Serve(g_s), s	0.1	0.0	0.1	6.3	0.0	4.2	0.1	7.5	7.4	5.3	6.6	0.1
Cycle Q Clear(g_c), s	0.1	0.0	0.1	6.3	0.0	4.2	0.1	7.5	7.4	5.3	6.6	0.1
Prop In Lane	1.00		1.00	1.00		1.00	1.00		1.00	1.00		1.00
Lane Grp Cap(c), veh/h	267	0	201	282	237	201	491	1747	779	530	2103	938
V/C Ratio(X)	0.01	0.00	0.01	0.47	0.00	0.52	0.01	0.36	0.35	0.57	0.32	0.00
Avail Cap(c_a), veh/h	449	0	425	482	501	425	687	1747	779	547	2103	938
HCM Platoon Ratio	1.00	1.00	1.00	1.00	1.00	1.00	1.00	1.00	1.00	1.00	1.00	1.00
Upstream Filter(l)	1.00	0.00	1.00	1.00	1.00	1.00	1.00	1.00	1.00	1.00	1.00	1.00
Uniform Delay (d), s/veh	26.4	0.0	26.3	29.1	26.3	28.2	8.7	10.8	10.8	7.1	7.1	5.8
Incr Delay (d2), s/veh	0.0	0.0	0.0	1.2	0.0	2.1	0.0	0.6	1.3	1.4	0.4	0.0
Initial Q Delay(d3),s/veh	0.0	0.0	0.0	0.0	0.0	0.0	0.0	0.0	0.0	0.0	0.0	0.0
%ile BackOfQ(50%),veh/ln	0.0	0.0	0.0	2.1	0.0	1.7	0.0	2.7	2.5	1.7	2.2	0.0
Unsig. Movement Delay, s/veh												
LnGrp Delay(d),s/veh	26.4	0.0	26.4	30.3	26.3	30.2	8.7	11.4	12.0	8.4	7.5	5.8
LnGrp LOS	C	A	C	C	C	C	A	B	B	A	A	A
Approach Vol, veh/h		4			238			908			977	
Approach Delay, s/veh		26.4			30.3			11.6			7.8	
Approach LOS		C			C			B			A	
Timer - Assigned Phs	1	2		4	5	6		8				
Phs Duration (G+Y+Rc), s	12.3	41.4		15.2	5.4	48.3		15.2				
Change Period (Y+Rc), s	5.0	7.5		6.5	5.0	7.5		6.5				
Max Green Setting (Gmax), s	8.0	23.5		18.5	8.0	23.5		18.5				
Max Q Clear Time (g_c+l1), s	7.3	9.5		2.1	2.1	8.6		8.3				
Green Ext Time (p_c), s	0.1	4.5		0.0	0.0	4.1		0.5				

Intersection Summary

HCM 6th Ctrl Delay	12.0
HCM 6th LOS	B

Timings
1: Voyager Pkwy & Old Ranch Rd



Lane Group	EBL	EBT	WBL	WBT	WBR	NBL	NBT	NBR	SBL	SBT
Lane Configurations	↖	↗	↖	↗	↗	↖	↑↑	↗	↖	↑↑
Traffic Volume (vph)	3	4	270	1	261	1	647	103	160	503
Future Volume (vph)	3	4	270	1	261	1	647	103	160	503
Turn Type	Perm	NA	Perm	NA	Perm	pm+pt	NA	Perm	pm+pt	NA
Protected Phases		4		8		5	2		1	6
Permitted Phases	4		8		8	2		2	6	
Detector Phase	4	4	8	8	8	5	2	2	1	6
Switch Phase										
Minimum Initial (s)	4.0	4.0	4.0	4.0	4.0	4.0	23.0	23.0	4.0	23.0
Minimum Split (s)	24.5	24.5	24.5	24.5	24.5	10.0	30.5	30.5	10.0	30.5
Total Split (s)	25.0	25.0	25.0	25.0	25.0	13.0	31.0	31.0	13.0	31.0
Total Split (%)	36.2%	36.2%	36.2%	36.2%	36.2%	18.8%	44.9%	44.9%	18.8%	44.9%
Yellow Time (s)	4.5	4.5	4.5	4.5	4.5	3.0	5.5	5.5	3.0	5.5
All-Red Time (s)	2.0	2.0	2.0	2.0	2.0	2.0	2.0	2.0	2.0	2.0
Lost Time Adjust (s)	0.0	0.0	0.0	0.0	0.0	0.0	0.0	0.0	0.0	0.0
Total Lost Time (s)	6.5	6.5	6.5	6.5	6.5	5.0	7.5	7.5	5.0	7.5
Lead/Lag						Lead	Lag	Lag	Lead	Lag
Lead-Lag Optimize?						Yes	Yes	Yes	Yes	Yes
Recall Mode	None	None	None	None	None	None	C-Max	C-Max	None	C-Max
Act Effct Green (s)	17.8	17.8	17.8	17.8	17.8	32.5	24.5	24.5	39.2	35.1
Actuated g/C Ratio	0.26	0.26	0.26	0.26	0.26	0.47	0.36	0.36	0.57	0.51
v/c Ratio	0.01	0.02	0.90	0.00	0.49	0.00	0.62	0.19	0.49	0.34
Control Delay	18.7	16.7	54.6	19.0	5.7	7.0	21.4	3.9	11.9	11.8
Queue Delay	0.0	0.0	0.0	0.0	0.0	0.0	0.0	0.0	0.0	0.0
Total Delay	18.7	16.7	54.6	19.0	5.7	7.0	21.4	3.9	11.9	11.8
LOS	B	B	D	B	A	A	C	A	B	B
Approach Delay		17.4		30.5			19.0			11.8
Approach LOS		B		C			B			B

Intersection Summary

Cycle Length: 69
 Actuated Cycle Length: 69
 Offset: 26 (38%), Referenced to phase 2:NBTL and 6:SBTL, Start of Green
 Natural Cycle: 65
 Control Type: Actuated-Coordinated
 Maximum v/c Ratio: 0.90
 Intersection Signal Delay: 19.7
 Intersection Capacity Utilization 65.5%
 Analysis Period (min) 15

Intersection LOS: B
 ICU Level of Service C

Splits and Phases: 1: Voyager Pkwy & Old Ranch Rd

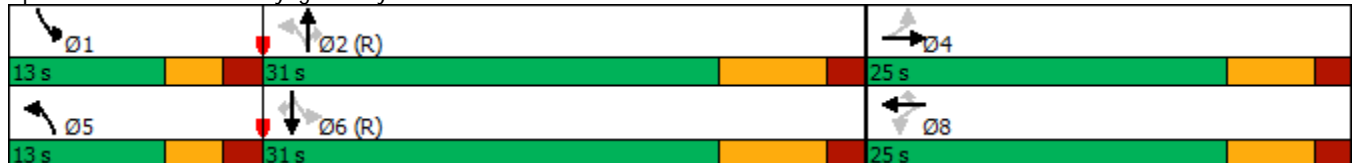

HCM 6th Signalized Intersection Summary
 1: Voyager Pkwy & Old Ranch Rd

2025 Background AM

09/06/2023

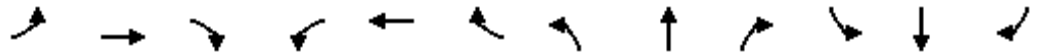

Movement	EBL	EBT	EBR	WBL	WBT	WBR	NBL	NBT	NBR	SBL	SBT	SBR
Lane Configurations												
Traffic Volume (veh/h)	3	4	2	270	1	261	1	647	103	160	503	0
Future Volume (veh/h)	3	4	2	270	1	261	1	647	103	160	503	0
Initial Q (Qb), veh	0	0	0	0	0	0	0	0	0	0	0	0
Ped-Bike Adj(A_pbT)	1.00		1.00	1.00		1.00	1.00		1.00	1.00		1.00
Parking Bus, Adj	1.00	1.00	1.00	1.00	1.00	1.00	1.00	1.00	1.00	1.00	1.00	1.00
Work Zone On Approach		No			No			No			No	
Adj Sat Flow, veh/h/ln	1870	1870	1870	1870	1870	1870	1870	1870	1870	1870	1870	1870
Adj Flow Rate, veh/h	4	5	2	325	1	314	1	780	124	193	606	0
Peak Hour Factor	0.83	0.83	0.83	0.83	0.83	0.83	0.83	0.83	0.83	0.83	0.83	0.83
Percent Heavy Veh, %	2	2	2	2	2	2	2	2	2	2	2	2
Cap, veh/h	379	329	132	465	484	410	396	1338	597	388	1651	737
Arrive On Green	0.26	0.26	0.26	0.26	0.26	0.26	0.00	0.38	0.38	0.09	0.46	0.00
Sat Flow, veh/h	1065	1271	508	1409	1870	1585	1781	3554	1585	1781	3554	1585
Grp Volume(v), veh/h	4	0	7	325	1	314	1	780	124	193	606	0
Grp Sat Flow(s),veh/h/ln	1065	0	1779	1409	1870	1585	1781	1777	1585	1781	1777	1585
Q Serve(g_s), s	0.2	0.0	0.2	15.4	0.0	12.6	0.0	12.1	3.7	4.2	7.6	0.0
Cycle Q Clear(g_c), s	0.2	0.0	0.2	15.6	0.0	12.6	0.0	12.1	3.7	4.2	7.6	0.0
Prop In Lane	1.00		0.29	1.00		1.00	1.00		1.00	1.00		1.00
Lane Grp Cap(c), veh/h	379	0	460	465	484	410	396	1338	597	388	1651	737
V/C Ratio(X)	0.01	0.00	0.02	0.70	0.00	0.77	0.00	0.58	0.21	0.50	0.37	0.00
Avail Cap(c_a), veh/h	389	0	477	478	501	425	600	1338	597	435	1651	737
HCM Platoon Ratio	1.00	1.00	1.00	1.00	1.00	1.00	1.00	1.00	1.00	1.00	1.00	1.00
Upstream Filter(I)	1.00	0.00	1.00	1.00	1.00	1.00	1.00	1.00	1.00	1.00	1.00	0.00
Uniform Delay (d), s/veh	19.0	0.0	19.0	24.8	19.0	23.6	13.4	17.2	14.6	12.0	11.9	0.0
Incr Delay (d2), s/veh	0.0	0.0	0.0	4.3	0.0	7.9	0.0	1.9	0.8	1.0	0.6	0.0
Initial Q Delay(d3),s/veh	0.0	0.0	0.0	0.0	0.0	0.0	0.0	0.0	0.0	0.0	0.0	0.0
%ile BackOfQ(50%),veh/ln	0.0	0.0	0.1	5.4	0.0	5.3	0.0	4.9	1.4	1.6	2.8	0.0
Unsig. Movement Delay, s/veh												
LnGrp Delay(d),s/veh	19.1	0.0	19.0	29.2	19.0	31.5	13.4	19.1	15.3	13.0	12.5	0.0
LnGrp LOS	B	A	B	C	B	C	B	B	B	B	B	A
Approach Vol, veh/h		11			640			905			799	
Approach Delay, s/veh		19.0			30.3			18.5			12.6	
Approach LOS		B			C			B			B	
Timer - Assigned Phs	1	2		4	5	6		8				
Phs Duration (G+Y+Rc), s	11.2	33.5		24.4	5.1	39.6		24.4				
Change Period (Y+Rc), s	5.0	7.5		6.5	5.0	7.5		6.5				
Max Green Setting (Gmax), s	8.0	23.5		18.5	8.0	23.5		18.5				
Max Q Clear Time (g_c+I1), s	6.2	14.1		2.2	2.0	9.6		17.6				
Green Ext Time (p_c), s	0.1	4.0		0.0	0.0	3.5		0.3				

Intersection Summary

HCM 6th Ctrl Delay	19.7
HCM 6th LOS	B

Timings
1: Voyager Pkwy & Old Ranch Rd



Lane Group	EBL	EBT	WBL	WBT	WBR	NBL	NBT	NBR	SBL	SBT	SBR
Lane Configurations	↖	↗	↖	↖	↗	↖	↖↗	↗	↖	↖↗	↗
Traffic Volume (vph)	2	0	128	1	100	6	601	264	291	643	3
Future Volume (vph)	2	0	128	1	100	6	601	264	291	643	3
Turn Type	Perm	NA	Perm	NA	Perm	pm+pt	NA	Perm	pm+pt	NA	Perm
Protected Phases		4		8		5	2		1	6	
Permitted Phases	4		8		8	2		2	6		6
Detector Phase	4	4	8	8	8	5	2	2	1	6	6
Switch Phase											
Minimum Initial (s)	4.0	4.0	4.0	4.0	4.0	4.0	23.0	23.0	4.0	23.0	23.0
Minimum Split (s)	24.5	24.5	24.5	24.5	24.5	10.0	30.5	30.5	10.0	30.5	30.5
Total Split (s)	25.0	25.0	25.0	25.0	25.0	13.0	31.0	31.0	13.0	31.0	31.0
Total Split (%)	36.2%	36.2%	36.2%	36.2%	36.2%	18.8%	44.9%	44.9%	18.8%	44.9%	44.9%
Yellow Time (s)	4.5	4.5	4.5	4.5	4.5	3.0	5.5	5.5	3.0	5.5	5.5
All-Red Time (s)	2.0	2.0	2.0	2.0	2.0	2.0	2.0	2.0	2.0	2.0	2.0
Lost Time Adjust (s)	0.0	0.0	0.0	0.0	0.0	0.0	0.0	0.0	0.0	0.0	0.0
Total Lost Time (s)	6.5	6.5	6.5	6.5	6.5	5.0	7.5	7.5	5.0	7.5	7.5
Lead/Lag						Lead	Lag	Lag	Lead	Lag	Lag
Lead-Lag Optimize?						Yes	Yes	Yes	Yes	Yes	Yes
Recall Mode	None	None	None	None	None	None	C-Max	C-Max	None	C-Max	C-Max
Act Effct Green (s)	12.0	12.0	12.0	12.0	12.0	36.3	28.2	28.2	45.2	40.9	40.9
Actuated g/C Ratio	0.17	0.17	0.17	0.17	0.17	0.53	0.41	0.41	0.66	0.59	0.59
v/c Ratio	0.01	0.00	0.57	0.00	0.27	0.01	0.45	0.35	0.56	0.33	0.00
Control Delay	20.5	0.0	34.4	21.0	3.7	6.2	17.1	3.8	10.0	9.3	0.0
Queue Delay	0.0	0.0	0.0	0.0	0.0	0.0	0.0	0.0	0.0	0.0	0.0
Total Delay	20.5	0.0	34.4	21.0	3.7	6.2	17.1	3.8	10.0	9.3	0.0
LOS	C	A	C	C	A	A	B	A	A	A	A
Approach Delay		10.3		20.9			13.0			9.5	
Approach LOS		B		C			B			A	

Intersection Summary

Cycle Length: 69
 Actuated Cycle Length: 69
 Offset: 26 (38%), Referenced to phase 2:NBTL and 6:SBTL, Start of Green
 Natural Cycle: 65
 Control Type: Actuated-Coordinated
 Maximum v/c Ratio: 0.57
 Intersection Signal Delay: 12.3
 Intersection LOS: B
 Intersection Capacity Utilization 64.9%
 ICU Level of Service C
 Analysis Period (min) 15

Splits and Phases: 1: Voyager Pkwy & Old Ranch Rd

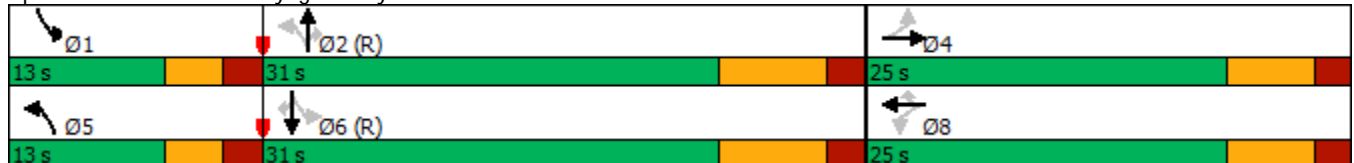

HCM 6th Signalized Intersection Summary
1: Voyager Pkwy & Old Ranch Rd

2025 Background PM

09/06/2023



Movement	EBL	EBT	EBR	WBL	WBT	WBR	NBL	NBT	NBR	SBL	SBT	SBR
Lane Configurations												
Traffic Volume (veh/h)	2	0	2	128	1	100	6	601	264	291	643	3
Future Volume (veh/h)	2	0	2	128	1	100	6	601	264	291	643	3
Initial Q (Qb), veh	0	0	0	0	0	0	0	0	0	0	0	0
Ped-Bike Adj(A_pbT)	1.00		1.00	1.00		1.00	1.00		1.00	1.00		1.00
Parking Bus, Adj	1.00	1.00	1.00	1.00	1.00	1.00	1.00	1.00	1.00	1.00	1.00	1.00
Work Zone On Approach		No			No			No			No	
Adj Sat Flow, veh/h/ln	1870	1870	1870	1870	1870	1870	1870	1870	1870	1870	1870	1870
Adj Flow Rate, veh/h	2	0	2	138	1	108	6	646	284	313	691	3
Peak Hour Factor	0.93	0.93	0.93	0.93	0.93	0.93	0.93	0.93	0.93	0.93	0.93	0.93
Percent Heavy Veh, %	2	2	2	2	2	2	2	2	2	2	2	2
Cap, veh/h	271	0	207	287	244	207	479	1721	768	522	2089	932
Arrive On Green	0.13	0.00	0.13	0.13	0.13	0.13	0.01	0.48	0.48	0.11	0.59	0.59
Sat Flow, veh/h	1284	0	1585	1415	1870	1585	1781	3554	1585	1781	3554	1585
Grp Volume(v), veh/h	2	0	2	138	1	108	6	646	284	313	691	3
Grp Sat Flow(s),veh/h/ln	1284	0	1585	1415	1870	1585	1781	1777	1585	1781	1777	1585
Q Serve(g_s), s	0.1	0.0	0.1	6.5	0.0	4.4	0.1	7.9	7.8	5.5	6.9	0.1
Cycle Q Clear(g_c), s	0.1	0.0	0.1	6.6	0.0	4.4	0.1	7.9	7.8	5.5	6.9	0.1
Prop In Lane	1.00		1.00	1.00		1.00	1.00		1.00	1.00		1.00
Lane Grp Cap(c), veh/h	271	0	207	287	244	207	479	1721	768	522	2089	932
V/C Ratio(X)	0.01	0.00	0.01	0.48	0.00	0.52	0.01	0.38	0.37	0.60	0.33	0.00
Avail Cap(c_a), veh/h	448	0	425	482	501	425	674	1721	768	533	2089	932
HCM Platoon Ratio	1.00	1.00	1.00	1.00	1.00	1.00	1.00	1.00	1.00	1.00	1.00	1.00
Upstream Filter(l)	1.00	0.00	1.00	1.00	1.00	1.00	1.00	1.00	1.00	1.00	1.00	1.00
Uniform Delay (d), s/veh	26.2	0.0	26.1	29.0	26.1	28.0	9.0	11.2	11.2	7.4	7.3	5.9
Incr Delay (d2), s/veh	0.0	0.0	0.0	1.2	0.0	2.0	0.0	0.6	1.4	1.8	0.4	0.0
Initial Q Delay(d3),s/veh	0.0	0.0	0.0	0.0	0.0	0.0	0.0	0.0	0.0	0.0	0.0	0.0
%ile BackOfQ(50%),veh/ln	0.0	0.0	0.0	2.2	0.0	1.7	0.0	2.9	2.7	1.9	2.3	0.0
Unsig. Movement Delay, s/veh												
LnGrp Delay(d),s/veh	26.2	0.0	26.1	30.2	26.1	30.0	9.0	11.8	12.5	9.2	7.7	5.9
LnGrp LOS	C	A	C	C	C	C	A	B	B	A	A	A
Approach Vol, veh/h		4			247			936			1007	
Approach Delay, s/veh		26.2			30.1			12.0			8.2	
Approach LOS		C			C			B			A	
Timer - Assigned Phs	1	2		4	5	6		8				
Phs Duration (G+Y+Rc), s	12.6	40.9		15.5	5.4	48.1		15.5				
Change Period (Y+Rc), s	5.0	7.5		6.5	5.0	7.5		6.5				
Max Green Setting (Gmax), s	8.0	23.5		18.5	8.0	23.5		18.5				
Max Q Clear Time (g_c+I1), s	7.5	9.9		2.1	2.1	8.9		8.6				
Green Ext Time (p_c), s	0.1	4.6		0.0	0.0	4.2		0.5				

Intersection Summary

HCM 6th Ctrl Delay	12.3
HCM 6th LOS	B

Timings
1: Voyager Pkwy & Old Ranch Rd

2025 Total AM
09/06/2023



Lane Group	EBL	EBT	WBL	WBT	WBR	NBL	NBT	NBR	SBL	SBT
Lane Configurations	↖	↗	↖	↗	↗	↖	↑↑	↗	↖	↑↑
Traffic Volume (vph)	3	4	314	1	305	1	647	119	176	503
Future Volume (vph)	3	4	314	1	305	1	647	119	176	503
Turn Type	Perm	NA	Perm	NA	Perm	pm+pt	NA	Perm	pm+pt	NA
Protected Phases		4		8		5	2		1	6
Permitted Phases	4		8		8	2		2	6	
Detector Phase	4	4	8	8	8	5	2	2	1	6
Switch Phase										
Minimum Initial (s)	4.0	4.0	4.0	4.0	4.0	4.0	23.0	23.0	4.0	23.0
Minimum Split (s)	24.5	24.5	24.5	24.5	24.5	10.0	30.5	30.5	10.0	30.5
Total Split (s)	25.0	25.0	25.0	25.0	25.0	13.0	31.0	31.0	13.0	31.0
Total Split (%)	36.2%	36.2%	36.2%	36.2%	36.2%	18.8%	44.9%	44.9%	18.8%	44.9%
Yellow Time (s)	4.5	4.5	4.5	4.5	4.5	3.0	5.5	5.5	3.0	5.5
All-Red Time (s)	2.0	2.0	2.0	2.0	2.0	2.0	2.0	2.0	2.0	2.0
Lost Time Adjust (s)	0.0	0.0	0.0	0.0	0.0	0.0	0.0	0.0	0.0	0.0
Total Lost Time (s)	6.5	6.5	6.5	6.5	6.5	5.0	7.5	7.5	5.0	7.5
Lead/Lag						Lead	Lag	Lag	Lead	Lag
Lead-Lag Optimize?						Yes	Yes	Yes	Yes	Yes
Recall Mode	None	None	None	None	None	None	C-Max	C-Max	None	C-Max
Act Effect Green (s)	18.5	18.5	18.5	18.5	18.5	31.8	23.7	23.7	38.5	34.4
Actuated g/C Ratio	0.27	0.27	0.27	0.27	0.27	0.46	0.34	0.34	0.56	0.50
v/c Ratio	0.01	0.01	1.01	0.00	0.56	0.00	0.64	0.22	0.55	0.34
Control Delay	18.7	16.7	76.9	19.0	8.2	7.0	22.1	4.3	13.4	12.0
Queue Delay	0.0	0.0	0.0	0.0	0.0	0.0	0.0	0.0	0.0	0.0
Total Delay	18.7	16.7	76.9	19.0	8.2	7.0	22.1	4.3	13.4	12.0
LOS	B	B	E	B	A	A	C	A	B	B
Approach Delay		17.4		43.0			19.3			12.4
Approach LOS		B		D			B			B

Intersection Summary

Cycle Length: 69
 Actuated Cycle Length: 69
 Offset: 26 (38%), Referenced to phase 2:NBTL and 6:SBTL, Start of Green
 Natural Cycle: 70
 Control Type: Actuated-Coordinated
 Maximum v/c Ratio: 1.01
 Intersection Signal Delay: 24.1
 Intersection Capacity Utilization 68.8%
 Analysis Period (min) 15

Intersection LOS: C
 ICU Level of Service C

Splits and Phases: 1: Voyager Pkwy & Old Ranch Rd

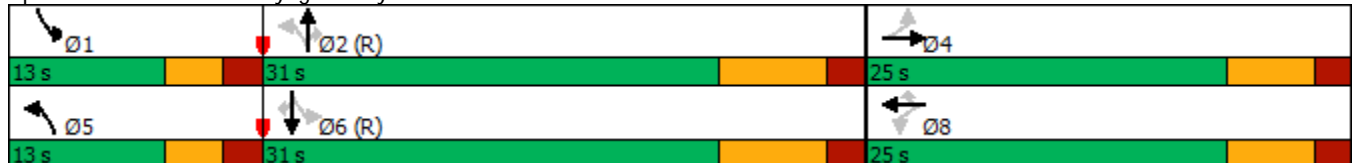

HCM 6th Signalized Intersection Summary
 1: Voyager Pkwy & Old Ranch Rd

2025 Total AM
 09/06/2023

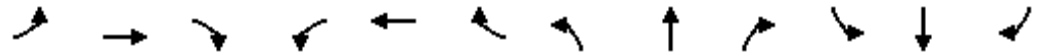

Movement	EBL	EBT	EBR	WBL	WBT	WBR	NBL	NBT	NBR	SBL	SBT	SBR
Lane Configurations												
Traffic Volume (veh/h)	3	4	2	314	1	305	1	647	119	176	503	0
Future Volume (veh/h)	3	4	2	314	1	305	1	647	119	176	503	0
Initial Q (Qb), veh	0	0	0	0	0	0	0	0	0	0	0	0
Ped-Bike Adj(A_pbT)	1.00		1.00	1.00		1.00	1.00		1.00	1.00		1.00
Parking Bus, Adj	1.00	1.00	1.00	1.00	1.00	1.00	1.00	1.00	1.00	1.00	1.00	1.00
Work Zone On Approach		No			No			No			No	
Adj Sat Flow, veh/h/ln	1870	1870	1870	1870	1870	1870	1870	1870	1870	1870	1870	1870
Adj Flow Rate, veh/h	4	5	2	378	1	367	1	780	143	212	606	0
Peak Hour Factor	0.83	0.83	0.83	0.83	0.83	0.83	0.83	0.83	0.83	0.83	0.83	0.83
Percent Heavy Veh, %	2	2	2	2	2	2	2	2	2	2	2	2
Cap, veh/h	376	341	136	478	501	425	387	1275	569	387	1618	722
Arrive On Green	0.27	0.27	0.27	0.27	0.27	0.27	0.00	0.36	0.36	0.10	0.46	0.00
Sat Flow, veh/h	1014	1271	508	1409	1870	1585	1781	3554	1585	1781	3554	1585
Grp Volume(v), veh/h	4	0	7	378	1	367	1	780	143	212	606	0
Grp Sat Flow(s),veh/h/ln	1014	0	1779	1409	1870	1585	1781	1777	1585	1781	1777	1585
Q Serve(g_s), s	0.2	0.0	0.2	18.3	0.0	15.2	0.0	12.4	4.4	4.8	7.7	0.0
Cycle Q Clear(g_c), s	0.2	0.0	0.2	18.5	0.0	15.2	0.0	12.4	4.4	4.8	7.7	0.0
Prop In Lane	1.00		0.29	1.00		1.00	1.00		1.00	1.00		1.00
Lane Grp Cap(c), veh/h	376	0	477	478	501	425	387	1275	569	387	1618	722
V/C Ratio(X)	0.01	0.00	0.01	0.79	0.00	0.86	0.00	0.61	0.25	0.55	0.37	0.00
Avail Cap(c_a), veh/h	376	0	477	478	501	425	591	1275	569	419	1618	722
HCM Platoon Ratio	1.00	1.00	1.00	1.00	1.00	1.00	1.00	1.00	1.00	1.00	1.00	1.00
Upstream Filter(l)	1.00	0.00	1.00	1.00	1.00	1.00	1.00	1.00	1.00	1.00	1.00	0.00
Uniform Delay (d), s/veh	18.6	0.0	18.6	25.5	18.5	24.0	14.1	18.2	15.6	12.7	12.3	0.0
Incr Delay (d2), s/veh	0.0	0.0	0.0	8.8	0.0	16.6	0.0	2.2	1.1	1.3	0.7	0.0
Initial Q Delay(d3),s/veh	0.0	0.0	0.0	0.0	0.0	0.0	0.0	0.0	0.0	0.0	0.0	0.0
%ile BackOfQ(50%),veh/ln	0.0	0.0	0.1	6.9	0.0	7.3	0.0	5.1	1.6	1.8	2.9	0.0
Unsig. Movement Delay, s/veh												
LnGrp Delay(d),s/veh	18.6	0.0	18.6	34.2	18.5	40.6	14.1	20.4	16.7	14.0	13.0	0.0
LnGrp LOS	B	A	B	C	B	D	B	C	B	B	B	A
Approach Vol, veh/h		11			746			924			818	
Approach Delay, s/veh		18.6			37.4			19.8			13.2	
Approach LOS		B			D			B			B	
Timer - Assigned Phs	1	2		4	5	6		8				
Phs Duration (G+Y+Rc), s	11.8	32.2		25.0	5.1	38.9		25.0				
Change Period (Y+Rc), s	5.0	7.5		6.5	5.0	7.5		6.5				
Max Green Setting (Gmax), s	8.0	23.5		18.5	8.0	23.5		18.5				
Max Q Clear Time (g_c+I1), s	6.8	14.4		2.2	2.0	9.7		20.5				
Green Ext Time (p_c), s	0.1	3.9		0.0	0.0	3.5		0.0				
Intersection Summary												
HCM 6th Ctrl Delay				22.9								
HCM 6th LOS				C								

Timings
1: Voyager Pkwy & Old Ranch Rd

2025 Total PM
09/06/2023



Lane Group	EBL	EBT	WBL	WBT	WBR	NBL	NBT	NBR	SBL	SBT	SBR
Lane Configurations	↖	↗	↖	↖	↖	↖	↖↖	↖	↖	↖↖	↖
Traffic Volume (vph)	2	0	159	1	131	6	601	316	343	643	3
Future Volume (vph)	2	0	159	1	131	6	601	316	343	643	3
Turn Type	Perm	NA	Perm	NA	Perm	pm+pt	NA	Perm	pm+pt	NA	Perm
Protected Phases		4		8		5	2		1	6	
Permitted Phases	4		8		8	2		2	6		6
Detector Phase	4	4	8	8	8	5	2	2	1	6	6
Switch Phase											
Minimum Initial (s)	4.0	4.0	4.0	4.0	4.0	4.0	23.0	23.0	4.0	23.0	23.0
Minimum Split (s)	24.5	24.5	24.5	24.5	24.5	10.0	30.5	30.5	10.0	30.5	30.5
Total Split (s)	25.0	25.0	25.0	25.0	25.0	13.0	31.0	31.0	13.0	31.0	31.0
Total Split (%)	36.2%	36.2%	36.2%	36.2%	36.2%	18.8%	44.9%	44.9%	18.8%	44.9%	44.9%
Yellow Time (s)	4.5	4.5	4.5	4.5	4.5	3.0	5.5	5.5	3.0	5.5	5.5
All-Red Time (s)	2.0	2.0	2.0	2.0	2.0	2.0	2.0	2.0	2.0	2.0	2.0
Lost Time Adjust (s)	0.0	0.0	0.0	0.0	0.0	0.0	0.0	0.0	0.0	0.0	0.0
Total Lost Time (s)	6.5	6.5	6.5	6.5	6.5	5.0	7.5	7.5	5.0	7.5	7.5
Lead/Lag						Lead	Lag	Lag	Lead	Lag	Lag
Lead-Lag Optimize?						Yes	Yes	Yes	Yes	Yes	Yes
Recall Mode	None	None	None	None	None	None	C-Max	C-Max	None	C-Max	C-Max
Act Effct Green (s)	13.4	13.4	13.4	13.4	13.4	34.4	26.2	26.2	43.5	39.4	39.4
Actuated g/C Ratio	0.19	0.19	0.19	0.19	0.19	0.50	0.38	0.38	0.63	0.57	0.57
v/c Ratio	0.01	0.00	0.63	0.00	0.33	0.01	0.48	0.42	0.68	0.34	0.00
Control Delay	19.5	0.0	35.0	19.0	6.0	6.7	18.5	4.0	16.7	10.2	0.0
Queue Delay	0.0	0.0	0.0	0.0	0.0	0.0	0.0	0.0	0.0	0.0	0.0
Total Delay	19.5	0.0	35.0	19.0	6.0	6.7	18.5	4.0	16.7	10.2	0.0
LOS	B	A	D	B	A	A	B	A	B	B	A
Approach Delay		9.8		21.9			13.5			12.4	
Approach LOS		A		C			B			B	

Intersection Summary

Cycle Length: 69
 Actuated Cycle Length: 69
 Offset: 26 (38%), Referenced to phase 2:NBTL and 6:SBTL, Start of Green
 Natural Cycle: 65
 Control Type: Actuated-Coordinated
 Maximum v/c Ratio: 0.68
 Intersection Signal Delay: 14.1
 Intersection LOS: B
 Intersection Capacity Utilization 69.5%
 ICU Level of Service C
 Analysis Period (min) 15

Splits and Phases: 1: Voyager Pkwy & Old Ranch Rd

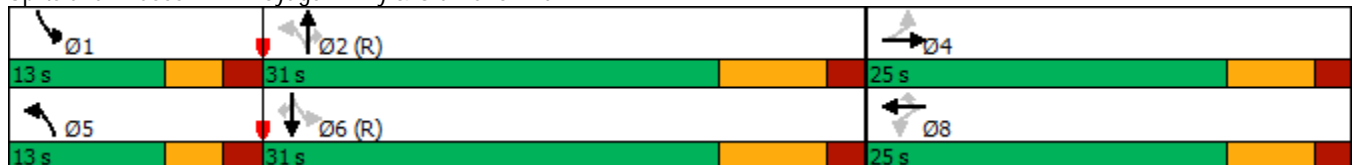

HCM 6th Signalized Intersection Summary
 1: Voyager Pkwy & Old Ranch Rd

2025 Total PM
 09/06/2023

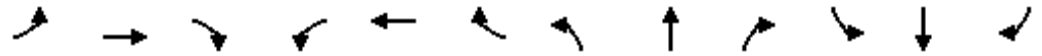

Movement	EBL	EBT	EBR	WBL	WBT	WBR	NBL	NBT	NBR	SBL	SBT	SBR
Lane Configurations												
Traffic Volume (veh/h)	2	0	2	159	1	131	6	601	316	343	643	3
Future Volume (veh/h)	2	0	2	159	1	131	6	601	316	343	643	3
Initial Q (Qb), veh	0	0	0	0	0	0	0	0	0	0	0	0
Ped-Bike Adj(A_pbT)	1.00		1.00	1.00		1.00	1.00		1.00	1.00		1.00
Parking Bus, Adj	1.00	1.00	1.00	1.00	1.00	1.00	1.00	1.00	1.00	1.00	1.00	1.00
Work Zone On Approach		No			No			No			No	
Adj Sat Flow, veh/h/ln	1870	1870	1870	1870	1870	1870	1870	1870	1870	1870	1870	1870
Adj Flow Rate, veh/h	2	0	2	171	1	141	6	646	340	369	691	3
Peak Hour Factor	0.93	0.93	0.93	0.93	0.93	0.93	0.93	0.93	0.93	0.93	0.93	0.93
Percent Heavy Veh, %	2	2	2	2	2	2	2	2	2	2	2	2
Cap, veh/h	297	0	246	322	290	246	456	1612	719	501	2002	893
Arrive On Green	0.16	0.00	0.16	0.16	0.16	0.16	0.01	0.45	0.45	0.12	0.56	0.56
Sat Flow, veh/h	1246	0	1585	1415	1870	1585	1781	3554	1585	1781	3554	1585
Grp Volume(v), veh/h	2	0	2	171	1	141	6	646	340	369	691	3
Grp Sat Flow(s),veh/h/ln	1246	0	1585	1415	1870	1585	1781	1777	1585	1781	1777	1585
Q Serve(g_s), s	0.1	0.0	0.1	8.0	0.0	5.7	0.1	8.4	10.3	7.2	7.3	0.1
Cycle Q Clear(g_c), s	0.1	0.0	0.1	8.1	0.0	5.7	0.1	8.4	10.3	7.2	7.3	0.1
Prop In Lane	1.00		1.00	1.00		1.00	1.00		1.00	1.00		1.00
Lane Grp Cap(c), veh/h	297	0	246	322	290	246	456	1612	719	501	2002	893
V/C Ratio(X)	0.01	0.00	0.01	0.53	0.00	0.57	0.01	0.40	0.47	0.74	0.35	0.00
Avail Cap(c_a), veh/h	438	0	425	482	501	425	651	1612	719	501	2002	893
HCM Platoon Ratio	1.00	1.00	1.00	1.00	1.00	1.00	1.00	1.00	1.00	1.00	1.00	1.00
Upstream Filter(l)	1.00	0.00	1.00	1.00	1.00	1.00	1.00	1.00	1.00	1.00	1.00	1.00
Uniform Delay (d), s/veh	24.7	0.0	24.7	28.1	24.6	27.0	10.1	12.6	13.1	9.2	8.2	6.6
Incr Delay (d2), s/veh	0.0	0.0	0.0	1.4	0.0	2.1	0.0	0.7	2.2	5.7	0.5	0.0
Initial Q Delay(d3),s/veh	0.0	0.0	0.0	0.0	0.0	0.0	0.0	0.0	0.0	0.0	0.0	0.0
%ile BackOfQ(50%),veh/ln	0.0	0.0	0.0	2.7	0.0	2.2	0.0	3.2	3.7	3.0	2.5	0.0
Unsig. Movement Delay, s/veh												
LnGrp Delay(d),s/veh	24.7	0.0	24.7	29.4	24.6	29.1	10.1	13.3	15.3	14.9	8.6	6.6
LnGrp LOS	C	A	C	C	C	C	B	B	B	B	A	A
Approach Vol, veh/h		4			313			992			1063	
Approach Delay, s/veh		24.7			29.3			14.0			10.8	
Approach LOS		C			C			B			B	
Timer - Assigned Phs	1	2		4	5	6		8				
Phs Duration (G+Y+Rc), s	13.0	38.8		17.2	5.4	46.4		17.2				
Change Period (Y+Rc), s	5.0	7.5		6.5	5.0	7.5		6.5				
Max Green Setting (Gmax), s	8.0	23.5		18.5	8.0	23.5		18.5				
Max Q Clear Time (g_c+I1), s	9.2	12.3		2.1	2.1	9.3		10.1				
Green Ext Time (p_c), s	0.0	4.3		0.0	0.0	4.1		0.6				

Intersection Summary

HCM 6th Ctrl Delay	14.6
HCM 6th LOS	B

Timings
1: Voyager Pkwy & Old Ranch Rd

2025 Total AM - Optimized

09/06/2023

Lane Group	EBL	EBT	WBL	WBT	WBR	NBL	NBT	NBR	SBL	SBT
Lane Configurations										
Traffic Volume (vph)	3	4	314	1	305	1	647	119	176	503
Future Volume (vph)	3	4	314	1	305	1	647	119	176	503
Turn Type	Perm	NA	Perm	NA	Perm	pm+pt	NA	Perm	pm+pt	NA
Protected Phases		4		8		5	2		1	6
Permitted Phases	4		8		8	2		2	6	
Detector Phase	4	4	8	8	8	5	2	2	1	6
Switch Phase										
Minimum Initial (s)	4.0	4.0	4.0	4.0	4.0	4.0	4.0	4.0	4.0	4.0
Minimum Split (s)	24.5	24.5	24.5	24.5	24.5	10.0	20.5	20.5	10.0	20.5
Total Split (s)	33.0	33.0	33.0	33.0	33.0	13.0	23.0	23.0	13.0	23.0
Total Split (%)	47.8%	47.8%	47.8%	47.8%	47.8%	18.8%	33.3%	33.3%	18.8%	33.3%
Yellow Time (s)	4.5	4.5	4.5	4.5	4.5	3.0	5.5	5.5	3.0	5.5
All-Red Time (s)	2.0	2.0	2.0	2.0	2.0	2.0	2.0	2.0	2.0	2.0
Lost Time Adjust (s)	0.0	0.0	0.0	0.0	0.0	0.0	0.0	0.0	0.0	0.0
Total Lost Time (s)	6.5	6.5	6.5	6.5	6.5	5.0	7.5	7.5	5.0	7.5
Lead/Lag						Lead	Lag	Lag	Lead	Lag
Lead-Lag Optimize?						Yes	Yes	Yes	Yes	Yes
Recall Mode	None	None	None	None	None	None	C-Max	C-Max	None	C-Max
Act Effct Green (s)	22.9	22.9	22.9	22.9	22.9	26.9	18.9	18.9	34.0	29.9
Actuated g/C Ratio	0.33	0.33	0.33	0.33	0.33	0.39	0.27	0.27	0.49	0.43
v/c Ratio	0.01	0.01	0.81	0.00	0.48	0.00	0.81	0.27	0.64	0.40
Control Delay	13.3	12.0	35.2	13.0	4.1	11.0	34.2	6.1	22.9	16.3
Queue Delay	0.0	0.0	0.0	0.0	0.0	0.0	0.0	0.0	0.0	0.0
Total Delay	13.3	12.0	35.2	13.0	4.1	11.0	34.2	6.1	22.9	16.3
LOS	B	B	D	B	A	B	C	A	C	B
Approach Delay		12.5		19.9			29.8			18.0
Approach LOS		B		B			C			B

Intersection Summary

Cycle Length: 69
 Actuated Cycle Length: 69
 Offset: 26 (38%), Referenced to phase 2:NBTL and 6:SBTL, Start of Green
 Natural Cycle: 60
 Control Type: Actuated-Coordinated
 Maximum v/c Ratio: 0.81
 Intersection Signal Delay: 22.9
 Intersection Capacity Utilization 67.5%
 Analysis Period (min) 15
 Intersection LOS: C
 ICU Level of Service C

Splits and Phases: 1: Voyager Pkwy & Old Ranch Rd

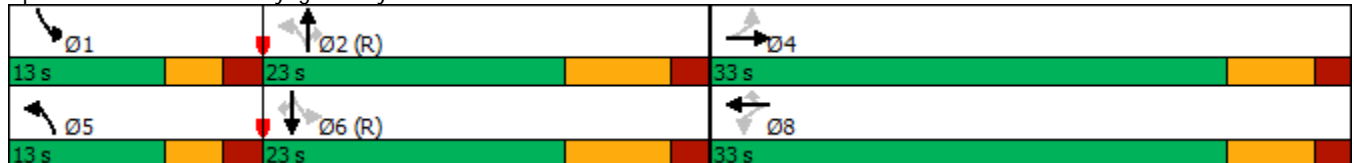

HCM 6th Signalized Intersection Summary
 1: Voyager Pkwy & Old Ranch Rd

2025 Total AM - Optimized

09/06/2023

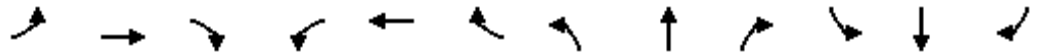

Movement	EBL	EBT	EBR	WBL	WBT	WBR	NBL	NBT	NBR	SBL	SBT	SBR
Lane Configurations												
Traffic Volume (veh/h)	3	4	2	314	1	305	1	647	119	176	503	0
Future Volume (veh/h)	3	4	2	314	1	305	1	647	119	176	503	0
Initial Q (Qb), veh	0	0	0	0	0	0	0	0	0	0	0	0
Ped-Bike Adj(A_pbT)	1.00		1.00	1.00		1.00	1.00		1.00	1.00		1.00
Parking Bus, Adj	1.00	1.00	1.00	1.00	1.00	1.00	1.00	1.00	1.00	1.00	1.00	1.00
Work Zone On Approach		No			No			No			No	
Adj Sat Flow, veh/h/ln	1870	1870	1870	1870	1870	1870	1870	1870	1870	1870	1870	1870
Adj Flow Rate, veh/h	4	5	2	378	1	367	1	780	143	212	606	0
Peak Hour Factor	0.83	0.83	0.83	0.83	0.83	0.83	0.83	0.83	0.83	0.83	0.83	0.83
Percent Heavy Veh, %	2	2	2	2	2	2	2	2	2	2	2	2
Cap, veh/h	418	393	157	536	578	490	346	1110	495	360	1472	657
Arrive On Green	0.31	0.31	0.31	0.31	0.31	0.31	0.00	0.31	0.31	0.10	0.41	0.00
Sat Flow, veh/h	1014	1271	508	1409	1870	1585	1781	3554	1585	1781	3554	1585
Grp Volume(v), veh/h	4	0	7	378	1	367	1	780	143	212	606	0
Grp Sat Flow(s),veh/h/ln	1014	0	1779	1409	1870	1585	1781	1777	1585	1781	1777	1585
Q Serve(g_s), s	0.2	0.0	0.2	17.5	0.0	14.4	0.0	13.3	4.7	5.2	8.3	0.0
Cycle Q Clear(g_c), s	0.2	0.0	0.2	17.7	0.0	14.4	0.0	13.3	4.7	5.2	8.3	0.0
Prop In Lane	1.00		0.29	1.00		1.00	1.00		1.00	1.00		1.00
Lane Grp Cap(c), veh/h	418	0	550	536	578	490	346	1110	495	360	1472	657
V/C Ratio(X)	0.01	0.00	0.01	0.71	0.00	0.75	0.00	0.70	0.29	0.59	0.41	0.00
Avail Cap(c_a), veh/h	493	0	683	641	718	609	550	1110	495	383	1472	657
HCM Platoon Ratio	1.00	1.00	1.00	1.00	1.00	1.00	1.00	1.00	1.00	1.00	1.00	1.00
Upstream Filter(l)	1.00	0.00	1.00	1.00	1.00	1.00	1.00	1.00	1.00	1.00	1.00	0.00
Uniform Delay (d), s/veh	16.5	0.0	16.5	22.7	16.5	21.4	16.3	20.9	17.9	14.7	14.3	0.0
Incr Delay (d2), s/veh	0.0	0.0	0.0	2.8	0.0	4.0	0.0	3.7	1.5	2.1	0.9	0.0
Initial Q Delay(d3),s/veh	0.0	0.0	0.0	0.0	0.0	0.0	0.0	0.0	0.0	0.0	0.0	0.0
%ile BackOfQ(50%),veh/ln	0.0	0.0	0.1	5.8	0.0	5.5	0.0	5.7	1.8	2.1	3.2	0.0
Unsig. Movement Delay, s/veh												
LnGrp Delay(d),s/veh	16.6	0.0	16.5	25.5	16.5	25.4	16.3	24.6	19.4	16.8	15.1	0.0
LnGrp LOS	B	A	B	C	B	C	B	C	B	B	B	A
Approach Vol, veh/h		11			746			924			818	
Approach Delay, s/veh		16.5			25.4			23.8			15.6	
Approach LOS		B			C			C			B	
Timer - Assigned Phs	1	2		4	5	6		8				
Phs Duration (G+Y+Rc), s	12.1	29.1		27.8	5.1	36.1		27.8				
Change Period (Y+Rc), s	5.0	7.5		6.5	5.0	7.5		6.5				
Max Green Setting (Gmax), s	8.0	15.5		26.5	8.0	15.5		26.5				
Max Q Clear Time (g_c+I1), s	7.2	15.3		2.2	2.0	10.3		19.7				
Green Ext Time (p_c), s	0.1	0.1		0.0	0.0	1.8		1.6				

Intersection Summary

HCM 6th Ctrl Delay	21.6
HCM 6th LOS	C

Timings
1: Voyager Pkwy & Old Ranch Rd

2045 Background AM

09/06/2023



Lane Group	EBL	EBT	WBL	WBT	WBR	NBL	NBT	NBR	SBL	SBT
Lane Configurations	↖	↗	↖	↗	↗	↖	↑↑	↗	↖	↑↑
Traffic Volume (vph)	4	6	364	1	351	1	871	139	215	677
Future Volume (vph)	4	6	364	1	351	1	871	139	215	677
Turn Type	Perm	NA	Perm	NA	Perm	pm+pt	NA	Perm	pm+pt	NA
Protected Phases		4		8		5	2		1	6
Permitted Phases	4		8		8	2		2	6	
Detector Phase	4	4	8	8	8	5	2	2	1	6
Switch Phase										
Minimum Initial (s)	4.0	4.0	4.0	4.0	4.0	4.0	23.0	23.0	4.0	23.0
Minimum Split (s)	24.5	24.5	24.5	24.5	24.5	10.0	30.5	30.5	10.0	30.5
Total Split (s)	25.0	25.0	25.0	25.0	25.0	13.0	31.0	31.0	13.0	31.0
Total Split (%)	36.2%	36.2%	36.2%	36.2%	36.2%	18.8%	44.9%	44.9%	18.8%	44.9%
Yellow Time (s)	4.5	4.5	4.5	4.5	4.5	3.0	5.5	5.5	3.0	5.5
All-Red Time (s)	2.0	2.0	2.0	2.0	2.0	2.0	2.0	2.0	2.0	2.0
Lost Time Adjust (s)	0.0	0.0	0.0	0.0	0.0	0.0	0.0	0.0	0.0	0.0
Total Lost Time (s)	6.5	6.5	6.5	6.5	6.5	5.0	7.5	7.5	5.0	7.5
Lead/Lag						Lead	Lag	Lag	Lead	Lag
Lead-Lag Optimize?						Yes	Yes	Yes	Yes	Yes
Recall Mode	None	None	None	None	None	None	C-Max	C-Max	None	C-Max
Act Effct Green (s)	18.5	18.5	18.5	18.5	18.5	31.5	23.5	23.5	38.5	34.4
Actuated g/C Ratio	0.27	0.27	0.27	0.27	0.27	0.46	0.34	0.34	0.56	0.50
v/c Ratio	0.01	0.02	1.17	0.00	0.67	0.00	0.87	0.26	0.81	0.46
Control Delay	18.8	16.0	130.4	19.0	13.3	7.0	31.2	4.2	33.5	13.2
Queue Delay	0.0	0.0	0.0	0.0	0.0	0.0	0.0	0.0	0.0	0.0
Total Delay	18.8	16.0	130.4	19.0	13.3	7.0	31.2	4.2	33.5	13.2
LOS	B	B	F	B	B	A	C	A	C	B
Approach Delay		16.9		72.9			27.5			18.1
Approach LOS		B		E			C			B

Intersection Summary

Cycle Length: 69
 Actuated Cycle Length: 69
 Offset: 26 (38%), Referenced to phase 2:NBTL and 6:SBTL, Start of Green
 Natural Cycle: 80
 Control Type: Actuated-Coordinated
 Maximum v/c Ratio: 1.17
 Intersection Signal Delay: 36.6
 Intersection LOS: D
 Intersection Capacity Utilization 78.7%
 ICU Level of Service D
 Analysis Period (min) 15

Splits and Phases: 1: Voyager Pkwy & Old Ranch Rd

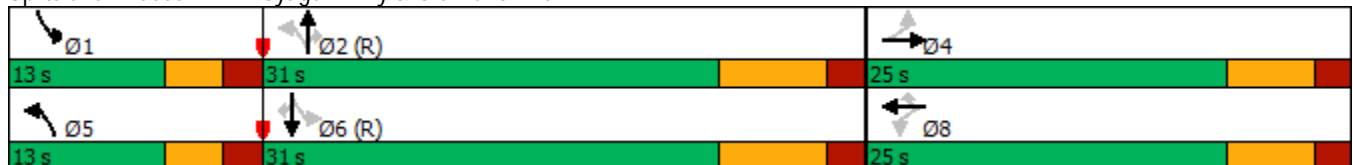

HCM 6th Signalized Intersection Summary
 1: Voyager Pkwy & Old Ranch Rd

2045 Background AM

09/06/2023



Movement	EBL	EBT	EBR	WBL	WBT	WBR	NBL	NBT	NBR	SBL	SBT	SBR
Lane Configurations												
Traffic Volume (veh/h)	4	6	3	364	1	351	1	871	139	215	677	0
Future Volume (veh/h)	4	6	3	364	1	351	1	871	139	215	677	0
Initial Q (Qb), veh	0	0	0	0	0	0	0	0	0	0	0	0
Ped-Bike Adj(A_pbT)	1.00		1.00	1.00		1.00	1.00		1.00	1.00		1.00
Parking Bus, Adj	1.00	1.00	1.00	1.00	1.00	1.00	1.00	1.00	1.00	1.00	1.00	1.00
Work Zone On Approach		No			No			No			No	
Adj Sat Flow, veh/h/ln	1870	1870	1870	1870	1870	1870	1870	1870	1870	1870	1870	1870
Adj Flow Rate, veh/h	5	7	4	439	1	423	1	1049	167	259	816	0
Peak Hour Factor	0.83	0.83	0.83	0.83	0.83	0.83	0.83	0.83	0.83	0.83	0.83	0.83
Percent Heavy Veh, %	2	2	2	2	2	2	2	2	2	2	2	2
Cap, veh/h	362	300	171	474	501	425	303	1211	540	340	1618	722
Arrive On Green	0.27	0.27	0.27	0.27	0.27	0.27	0.00	0.34	0.34	0.12	0.46	0.00
Sat Flow, veh/h	963	1117	638	1404	1870	1585	1781	3554	1585	1781	3554	1585
Grp Volume(v), veh/h	5	0	11	439	1	423	1	1049	167	259	816	0
Grp Sat Flow(s),veh/h/ln	963	0	1755	1404	1870	1585	1781	1777	1585	1781	1777	1585
Q Serve(g_s), s	0.3	0.0	0.3	18.2	0.0	18.4	0.0	19.0	5.4	6.0	11.2	0.0
Cycle Q Clear(g_c), s	0.3	0.0	0.3	18.5	0.0	18.4	0.0	19.0	5.4	6.0	11.2	0.0
Prop In Lane	1.00		0.36	1.00		1.00	1.00		1.00	1.00		1.00
Lane Grp Cap(c), veh/h	362	0	471	474	501	425	303	1211	540	340	1618	722
V/C Ratio(X)	0.01	0.00	0.02	0.93	0.00	1.00	0.00	0.87	0.31	0.76	0.50	0.00
Avail Cap(c_a), veh/h	362	0	471	474	501	425	507	1211	540	341	1618	722
HCM Platoon Ratio	1.00	1.00	1.00	1.00	1.00	1.00	1.00	1.00	1.00	1.00	1.00	1.00
Upstream Filter(l)	1.00	0.00	1.00	1.00	1.00	1.00	1.00	1.00	1.00	1.00	1.00	0.00
Uniform Delay (d), s/veh	18.6	0.0	18.6	26.8	18.5	25.2	15.0	21.3	16.8	15.1	13.3	0.0
Incr Delay (d2), s/veh	0.0	0.0	0.0	24.2	0.0	42.4	0.0	8.4	1.5	9.7	1.1	0.0
Initial Q Delay(d3),s/veh	0.0	0.0	0.0	0.0	0.0	0.0	0.0	0.0	0.0	0.0	0.0	0.0
%ile BackOfQ(50%),veh/ln	0.1	0.0	0.1	10.3	0.0	11.4	0.0	8.7	2.0	3.0	4.3	0.0
Unsig. Movement Delay, s/veh												
LnGrp Delay(d),s/veh	18.6	0.0	18.6	51.1	18.5	67.6	15.0	29.7	18.2	24.8	14.4	0.0
LnGrp LOS	B	A	B	D	B	E	B	C	B	C	B	A
Approach Vol, veh/h		16			863			1217			1075	
Approach Delay, s/veh		18.6			59.1			28.1			16.9	
Approach LOS		B			E			C			B	
Timer - Assigned Phs	1	2		4	5	6		8				
Phs Duration (G+Y+Rc), s	13.0	31.0		25.0	5.1	38.9		25.0				
Change Period (Y+Rc), s	5.0	7.5		6.5	5.0	7.5		6.5				
Max Green Setting (Gmax), s	8.0	23.5		18.5	8.0	23.5		18.5				
Max Q Clear Time (g_c+I1), s	8.0	21.0		2.3	2.0	13.2		20.5				
Green Ext Time (p_c), s	0.0	1.7		0.0	0.0	4.1		0.0				

Intersection Summary

HCM 6th Ctrl Delay	32.7
HCM 6th LOS	C

Timings
1: Voyager Pkwy & Old Ranch Rd



Lane Group	EBL	EBT	WBL	WBT	WBR	NBL	NBT	NBR	SBL	SBT	SBR
Lane Configurations	↖	↗	↖	↗	↗	↖	↕	↗	↖	↕	↗
Traffic Volume (vph)	3	0	172	1	135	8	809	355	391	866	4
Future Volume (vph)	3	0	172	1	135	8	809	355	391	866	4
Turn Type	Perm	NA	Perm	NA	Perm	pm+pt	NA	Perm	pm+pt	NA	Perm
Protected Phases		4		8		5	2		1	6	
Permitted Phases	4		8		8	2		2	6		6
Detector Phase	4	4	8	8	8	5	2	2	1	6	6
Switch Phase											
Minimum Initial (s)	4.0	4.0	4.0	4.0	4.0	4.0	23.0	23.0	4.0	23.0	23.0
Minimum Split (s)	24.5	24.5	24.5	24.5	24.5	10.0	30.5	30.5	10.0	30.5	30.5
Total Split (s)	25.0	25.0	25.0	25.0	25.0	13.0	31.0	31.0	13.0	31.0	31.0
Total Split (%)	36.2%	36.2%	36.2%	36.2%	36.2%	18.8%	44.9%	44.9%	18.8%	44.9%	44.9%
Yellow Time (s)	4.5	4.5	4.5	4.5	4.5	3.0	5.5	5.5	3.0	5.5	5.5
All-Red Time (s)	2.0	2.0	2.0	2.0	2.0	2.0	2.0	2.0	2.0	2.0	2.0
Lost Time Adjust (s)	0.0	0.0	0.0	0.0	0.0	0.0	0.0	0.0	0.0	0.0	0.0
Total Lost Time (s)	6.5	6.5	6.5	6.5	6.5	5.0	7.5	7.5	5.0	7.5	7.5
Lead/Lag							Lead	Lag	Lag	Lead	Lag
Lead-Lag Optimize?							Yes	Yes	Yes	Yes	Yes
Recall Mode	None	None	None	None	None	None	C-Max	C-Max	None	C-Max	C-Max
Act Effct Green (s)	13.9	13.9	13.9	13.9	13.9	31.7	23.5	23.5	43.0	38.9	38.9
Actuated g/C Ratio	0.20	0.20	0.20	0.20	0.20	0.46	0.34	0.34	0.62	0.56	0.56
v/c Ratio	0.01	0.01	0.66	0.00	0.33	0.02	0.72	0.48	0.90	0.47	0.00
Control Delay	19.3	0.0	36.0	19.0	6.1	6.8	24.0	4.4	40.4	11.7	0.0
Queue Delay	0.0	0.0	0.0	0.0	0.0	0.0	0.0	0.0	0.0	0.0	0.0
Total Delay	19.3	0.0	36.0	19.0	6.1	6.8	24.0	4.4	40.4	11.7	0.0
LOS	B	A	D	B	A	A	C	A	D	B	A
Approach Delay		9.7		22.8			18.0			20.5	
Approach LOS		A		C			B			C	

Intersection Summary

Cycle Length: 69
 Actuated Cycle Length: 69
 Offset: 26 (38%), Referenced to phase 2:NBTL and 6:SBTL, Start of Green
 Natural Cycle: 75
 Control Type: Actuated-Coordinated
 Maximum v/c Ratio: 0.90
 Intersection Signal Delay: 19.7
 Intersection LOS: B
 Intersection Capacity Utilization 76.1%
 ICU Level of Service D
 Analysis Period (min) 15

Splits and Phases: 1: Voyager Pkwy & Old Ranch Rd

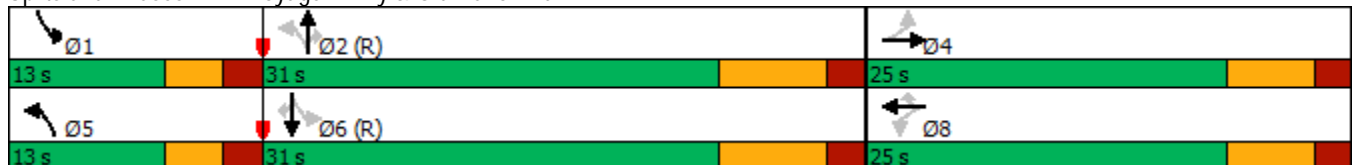

HCM 6th Signalized Intersection Summary
 1: Voyager Pkwy & Old Ranch Rd

2045 Background PM

09/06/2023

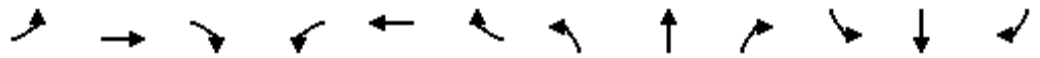

Movement	EBL	EBT	EBR	WBL	WBT	WBR	NBL	NBT	NBR	SBL	SBT	SBR
Lane Configurations												
Traffic Volume (veh/h)	3	0	3	172	1	135	8	809	355	391	866	4
Future Volume (veh/h)	3	0	3	172	1	135	8	809	355	391	866	4
Initial Q (Qb), veh	0	0	0	0	0	0	0	0	0	0	0	0
Ped-Bike Adj(A_pbT)	1.00		1.00	1.00		1.00	1.00		1.00	1.00		1.00
Parking Bus, Adj	1.00	1.00	1.00	1.00	1.00	1.00	1.00	1.00	1.00	1.00	1.00	1.00
Work Zone On Approach		No			No			No			No	
Adj Sat Flow, veh/h/ln	1870	1870	1870	1870	1870	1870	1870	1870	1870	1870	1870	1870
Adj Flow Rate, veh/h	3	0	3	185	1	145	9	870	382	420	931	4
Peak Hour Factor	0.93	0.93	0.93	0.93	0.93	0.93	0.93	0.93	0.93	0.93	0.93	0.93
Percent Heavy Veh, %	2	2	2	2	2	2	2	2	2	2	2	2
Cap, veh/h	309	0	262	336	309	262	354	1575	703	427	1954	872
Arrive On Green	0.17	0.00	0.17	0.17	0.17	0.17	0.01	0.44	0.44	0.12	0.55	0.55
Sat Flow, veh/h	1242	0	1585	1414	1870	1585	1781	3554	1585	1781	3554	1585
Grp Volume(v), veh/h	3	0	3	185	1	145	9	870	382	420	931	4
Grp Sat Flow(s),veh/h/ln	1242	0	1585	1414	1870	1585	1781	1777	1585	1781	1777	1585
Q Serve(g_s), s	0.1	0.0	0.1	8.7	0.0	5.8	0.2	12.5	12.2	8.0	11.0	0.1
Cycle Q Clear(g_c), s	0.2	0.0	0.1	8.8	0.0	5.8	0.2	12.5	12.2	8.0	11.0	0.1
Prop In Lane	1.00		1.00	1.00		1.00	1.00		1.00	1.00		1.00
Lane Grp Cap(c), veh/h	309	0	262	336	309	262	354	1575	703	427	1954	872
V/C Ratio(X)	0.01	0.00	0.01	0.55	0.00	0.55	0.03	0.55	0.54	0.98	0.48	0.00
Avail Cap(c_a), veh/h	437	0	425	481	501	425	545	1575	703	427	1954	872
HCM Platoon Ratio	1.00	1.00	1.00	1.00	1.00	1.00	1.00	1.00	1.00	1.00	1.00	1.00
Upstream Filter(l)	1.00	0.00	1.00	1.00	1.00	1.00	1.00	1.00	1.00	1.00	1.00	1.00
Uniform Delay (d), s/veh	24.1	0.0	24.1	27.8	24.0	26.4	10.5	14.2	14.1	14.0	9.5	7.0
Incr Delay (d2), s/veh	0.0	0.0	0.0	1.4	0.0	1.8	0.0	1.4	3.0	38.8	0.8	0.0
Initial Q Delay(d3),s/veh	0.0	0.0	0.0	0.0	0.0	0.0	0.0	0.0	0.0	0.0	0.0	0.0
%ile BackOfQ(50%),veh/ln	0.0	0.0	0.0	2.9	0.0	2.2	0.1	4.8	4.5	7.5	3.8	0.0
Unsig. Movement Delay, s/veh												
LnGrp Delay(d),s/veh	24.1	0.0	24.1	29.2	24.0	28.3	10.5	15.6	17.1	52.8	10.3	7.0
LnGrp LOS	C	A	C	C	C	C	B	B	B	D	B	A
Approach Vol, veh/h		6			331			1261			1355	
Approach Delay, s/veh		24.1			28.8			16.0			23.5	
Approach LOS		C			C			B			C	
Timer - Assigned Phs	1	2		4	5	6		8				
Phs Duration (G+Y+Rc), s	13.0	38.1		17.9	5.6	45.4		17.9				
Change Period (Y+Rc), s	5.0	7.5		6.5	5.0	7.5		6.5				
Max Green Setting (Gmax), s	8.0	23.5		18.5	8.0	23.5		18.5				
Max Q Clear Time (g_c+l1), s	10.0	14.5		2.2	2.2	13.0		10.8				
Green Ext Time (p_c), s	0.0	4.9		0.0	0.0	4.7		0.6				

Intersection Summary

HCM 6th Ctrl Delay	20.9
HCM 6th LOS	C

Timings
1: Voyager Pkwy & Old Ranch Rd

2045 Total AM

09/06/2023



Lane Group	EBL	EBT	WBL	WBT	WBR	NBL	NBT	NBR	SBL	SBT
Lane Configurations	↖	↗	↖	↗	↗	↖	↑↑	↗	↖	↑↑
Traffic Volume (vph)	4	6	408	1	395	1	871	155	231	677
Future Volume (vph)	4	6	408	1	395	1	871	155	231	677
Turn Type	Perm	NA	Perm	NA	Perm	pm+pt	NA	Perm	pm+pt	NA
Protected Phases		4		8		5	2		1	6
Permitted Phases	4		8		8	2		2	6	
Detector Phase	4	4	8	8	8	5	2	2	1	6
Switch Phase										
Minimum Initial (s)	4.0	4.0	4.0	4.0	4.0	4.0	4.0	4.0	4.0	4.0
Minimum Split (s)	24.5	24.5	24.5	24.5	24.5	10.0	16.5	16.5	10.0	16.5
Total Split (s)	35.0	35.0	35.0	35.0	35.0	10.0	24.0	24.0	10.0	24.0
Total Split (%)	50.7%	50.7%	50.7%	50.7%	50.7%	14.5%	34.8%	34.8%	14.5%	34.8%
Yellow Time (s)	4.5	4.5	4.5	4.5	4.5	3.0	5.5	5.5	3.0	5.5
All-Red Time (s)	2.0	2.0	2.0	2.0	2.0	2.0	2.0	2.0	2.0	2.0
Lost Time Adjust (s)	0.0	0.0	0.0	0.0	0.0	0.0	0.0	0.0	0.0	0.0
Total Lost Time (s)	6.5	6.5	6.5	6.5	6.5	5.0	7.5	7.5	5.0	7.5
Lead/Lag						Lead	Lag	Lag	Lead	Lag
Lead-Lag Optimize?						Yes	Yes	Yes	Yes	Yes
Recall Mode	None	None	None	None	None	None	C-Max	C-Max	None	C-Max
Act Effect Green (s)	27.2	27.2	27.2	27.2	27.2	24.1	16.5	16.5	29.3	25.8
Actuated g/C Ratio	0.39	0.39	0.39	0.39	0.39	0.35	0.24	0.24	0.42	0.37
v/c Ratio	0.01	0.02	0.89	0.00	0.61	0.00	1.24	0.36	1.01	0.62
Control Delay	12.0	10.2	40.5	12.0	10.8	12.0	144.8	6.1	81.4	22.8
Queue Delay	0.0	0.0	0.0	0.0	0.0	0.0	0.0	0.0	0.0	0.0
Total Delay	12.0	10.2	40.5	12.0	10.8	12.0	144.8	6.1	81.4	22.8
LOS	B	B	D	B	B	B	F	A	F	C
Approach Delay		10.8		25.9			123.8			37.7
Approach LOS		B		C			F			D

Intersection Summary

Cycle Length: 69

Actuated Cycle Length: 69

Offset: 26 (38%), Referenced to phase 2:NBTL and 6:SBTL, Start of Green

Natural Cycle: 90

Control Type: Actuated-Coordinated

Maximum v/c Ratio: 1.24

Intersection Signal Delay: 66.2

Intersection LOS: E

Intersection Capacity Utilization 82.0%

ICU Level of Service D

Analysis Period (min) 15

Splits and Phases: 1: Voyager Pkwy & Old Ranch Rd

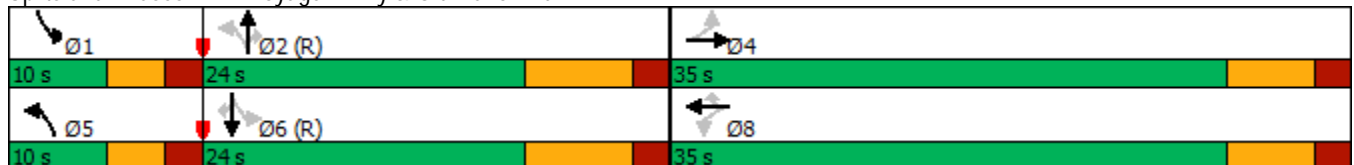

HCM 6th Signalized Intersection Summary
 1: Voyager Pkwy & Old Ranch Rd

2045 Total AM

09/06/2023

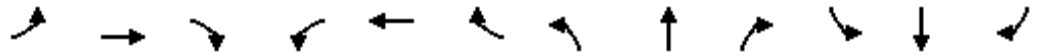

Movement	EBL	EBT	EBR	WBL	WBT	WBR	NBL	NBT	NBR	SBL	SBT	SBR
Lane Configurations												
Traffic Volume (veh/h)	4	6	3	408	1	395	1	871	155	231	677	0
Future Volume (veh/h)	4	6	3	408	1	395	1	871	155	231	677	0
Initial Q (Qb), veh	0	0	0	0	0	0	0	0	0	0	0	0
Ped-Bike Adj(A_pbT)	1.00		1.00	1.00		1.00	1.00		1.00	1.00		1.00
Parking Bus, Adj	1.00	1.00	1.00	1.00	1.00	1.00	1.00	1.00	1.00	1.00	1.00	1.00
Work Zone On Approach		No			No			No			No	
Adj Sat Flow, veh/h/ln	1870	1870	1870	1870	1870	1870	1870	1870	1870	1870	1870	1870
Adj Flow Rate, veh/h	5	7	4	492	1	476	1	1049	187	278	816	0
Peak Hour Factor	0.83	0.83	0.83	0.83	0.83	0.83	0.83	0.83	0.83	0.83	0.83	0.83
Percent Heavy Veh, %	2	2	2	2	2	2	2	2	2	2	2	2
Cap, veh/h	457	430	246	639	720	610	202	949	423	233	1203	536
Arrive On Green	0.39	0.39	0.39	0.39	0.39	0.39	0.00	0.27	0.27	0.07	0.34	0.00
Sat Flow, veh/h	917	1117	638	1404	1870	1585	1781	3554	1585	1781	3554	1585
Grp Volume(v), veh/h	5	0	11	492	1	476	1	1049	187	278	816	0
Grp Sat Flow(s),veh/h/ln	917	0	1755	1404	1870	1585	1781	1777	1585	1781	1777	1585
Q Serve(g_s), s	0.2	0.0	0.3	23.0	0.0	18.2	0.0	18.4	6.8	5.0	13.6	0.0
Cycle Q Clear(g_c), s	0.3	0.0	0.3	23.3	0.0	18.2	0.0	18.4	6.8	5.0	13.6	0.0
Prop In Lane	1.00		0.36	1.00		1.00	1.00		1.00	1.00		1.00
Lane Grp Cap(c), veh/h	457	0	676	639	720	610	202	949	423	233	1203	536
V/C Ratio(X)	0.01	0.00	0.02	0.77	0.00	0.78	0.00	1.11	0.44	1.19	0.68	0.00
Avail Cap(c_a), veh/h	483	0	725	679	773	655	328	949	423	233	1203	536
HCM Platoon Ratio	1.00	1.00	1.00	1.00	1.00	1.00	1.00	1.00	1.00	1.00	1.00	1.00
Upstream Filter(l)	1.00	0.00	1.00	1.00	1.00	1.00	1.00	1.00	1.00	1.00	1.00	0.00
Uniform Delay (d), s/veh	13.1	0.0	13.1	20.3	13.1	18.6	19.0	25.3	21.0	21.9	19.6	0.0
Incr Delay (d2), s/veh	0.0	0.0	0.0	5.1	0.0	5.7	0.0	62.5	3.3	120.3	3.1	0.0
Initial Q Delay(d3),s/veh	0.0	0.0	0.0	0.0	0.0	0.0	0.0	0.0	0.0	0.0	0.0	0.0
%ile BackOfQ(50%),veh/ln	0.0	0.0	0.1	7.7	0.0	7.0	0.0	15.5	2.8	9.1	5.7	0.0
Unsig. Movement Delay, s/veh												
LnGrp Delay(d),s/veh	13.1	0.0	13.1	25.4	13.1	24.3	19.0	87.7	24.3	142.1	22.7	0.0
LnGrp LOS	B	A	B	C	B	C	B	F	C	F	C	A
Approach Vol, veh/h		16			969			1237			1094	
Approach Delay, s/veh		13.1			24.9			78.1			53.0	
Approach LOS		B			C			E			D	
Timer - Assigned Phs	1	2		4	5	6		8				
Phs Duration (G+Y+Rc), s	10.0	25.9		33.1	5.1	30.9		33.1				
Change Period (Y+Rc), s	5.0	7.5		6.5	5.0	7.5		6.5				
Max Green Setting (Gmax), s	5.0	16.5		28.5	5.0	16.5		28.5				
Max Q Clear Time (g_c+I1), s	7.0	20.4		2.3	2.0	15.6		25.3				
Green Ext Time (p_c), s	0.0	0.0		0.0	0.0	0.5		1.3				

Intersection Summary

HCM 6th Ctrl Delay	54.0
HCM 6th LOS	D

Timings
1: Voyager Pkwy & Old Ranch Rd

2045 Total PM

09/06/2023



Lane Group	EBL	EBT	WBL	WBT	WBR	NBL	NBT	NBR	SBL	SBT	SBR
Lane Configurations	↖	↗	↖	↖	↗	↖	↖↗	↗	↖	↖↗	↗
Traffic Volume (vph)	3	0	203	1	166	8	809	407	443	866	4
Future Volume (vph)	3	0	203	1	166	8	809	407	443	866	4
Turn Type	Perm	NA	Perm	NA	Perm	pm+pt	NA	Perm	pm+pt	NA	Perm
Protected Phases		4		8		5	2		1	6	
Permitted Phases	4		8		8	2		2	6		6
Detector Phase	4	4	8	8	8	5	2	2	1	6	6
Switch Phase											
Minimum Initial (s)	4.0	4.0	4.0	4.0	4.0	4.0	14.0	14.0	4.0	23.0	23.0
Minimum Split (s)	24.5	24.5	24.5	24.5	24.5	10.0	21.5	21.5	10.0	30.5	30.5
Total Split (s)	24.5	24.5	24.5	24.5	24.5	10.0	21.5	21.5	23.0	34.5	34.5
Total Split (%)	35.5%	35.5%	35.5%	35.5%	35.5%	14.5%	31.2%	31.2%	33.3%	50.0%	50.0%
Yellow Time (s)	4.5	4.5	4.5	4.5	4.5	3.0	5.5	5.5	3.0	5.5	5.5
All-Red Time (s)	2.0	2.0	2.0	2.0	2.0	2.0	2.0	2.0	2.0	2.0	2.0
Lost Time Adjust (s)	0.0	0.0	0.0	0.0	0.0	0.0	0.0	0.0	0.0	0.0	0.0
Total Lost Time (s)	6.5	6.5	6.5	6.5	6.5	5.0	7.5	7.5	5.0	7.5	7.5
Lead/Lag							Lead	Lag	Lag	Lead	Lag
Lead-Lag Optimize?							Yes	Yes	Yes	Yes	Yes
Recall Mode	None	None	None	None	None	None	C-Max	C-Max	None	C-Max	C-Max
Act Effct Green (s)	14.8	14.8	14.8	14.8	14.8	27.1	19.3	19.3	42.7	38.2	38.2
Actuated g/C Ratio	0.21	0.21	0.21	0.21	0.21	0.39	0.28	0.28	0.62	0.55	0.55
v/c Ratio	0.01	0.01	0.72	0.00	0.34	0.03	0.88	0.58	0.90	0.48	0.00
Control Delay	19.3	0.0	38.7	19.0	3.4	8.9	40.7	6.4	37.3	11.9	0.0
Queue Delay	0.0	0.0	0.0	0.0	0.0	0.0	0.0	0.0	0.0	0.0	0.0
Total Delay	19.3	0.0	38.7	19.0	3.4	8.9	40.7	6.4	37.3	11.9	0.0
LOS	B	A	D	B	A	A	D	A	D	B	A
Approach Delay		9.7		22.8			29.1			20.4	
Approach LOS		A		C			C			C	

Intersection Summary

Cycle Length: 69
 Actuated Cycle Length: 69
 Offset: 26 (38%), Referenced to phase 2:NBTL and 6:SBTL, Start of Green
 Natural Cycle: 80
 Control Type: Actuated-Coordinated
 Maximum v/c Ratio: 0.90
 Intersection Signal Delay: 24.3
 Intersection LOS: C
 Intersection Capacity Utilization 80.7%
 ICU Level of Service D
 Analysis Period (min) 15

Splits and Phases: 1: Voyager Pkwy & Old Ranch Rd

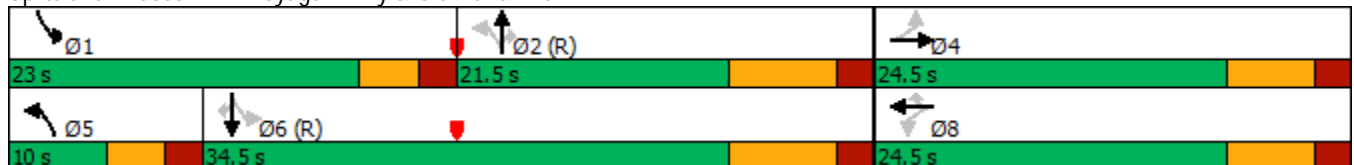

HCM 6th Signalized Intersection Summary
 1: Voyager Pkwy & Old Ranch Rd

2045 Total PM

09/06/2023

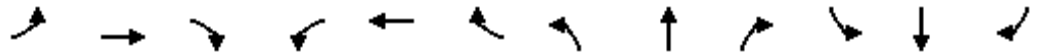

Movement	EBL	EBT	EBR	WBL	WBT	WBR	NBL	NBT	NBR	SBL	SBT	SBR
Lane Configurations												
Traffic Volume (veh/h)	3	0	3	203	1	166	8	809	407	443	866	4
Future Volume (veh/h)	3	0	3	203	1	166	8	809	407	443	866	4
Initial Q (Qb), veh	0	0	0	0	0	0	0	0	0	0	0	0
Ped-Bike Adj(A_pbT)	1.00		1.00	1.00		1.00	1.00		1.00	1.00		1.00
Parking Bus, Adj	1.00	1.00	1.00	1.00	1.00	1.00	1.00	1.00	1.00	1.00	1.00	1.00
Work Zone On Approach		No			No			No			No	
Adj Sat Flow, veh/h/ln	1870	1870	1870	1870	1870	1870	1870	1870	1870	1870	1870	1870
Adj Flow Rate, veh/h	3	0	3	218	1	178	9	870	438	476	931	4
Peak Hour Factor	0.93	0.93	0.93	0.93	0.93	0.93	0.93	0.93	0.93	0.93	0.93	0.93
Percent Heavy Veh, %	2	2	2	2	2	2	2	2	2	2	2	2
Cap, veh/h	331	0	298	368	352	298	315	1152	514	526	1873	836
Arrive On Green	0.19	0.00	0.19	0.19	0.19	0.19	0.01	0.32	0.32	0.21	0.53	0.53
Sat Flow, veh/h	1205	0	1585	1414	1870	1585	1781	3554	1585	1781	3554	1585
Grp Volume(v), veh/h	3	0	3	218	1	178	9	870	438	476	931	4
Grp Sat Flow(s),veh/h/ln	1205	0	1585	1414	1870	1585	1781	1777	1585	1781	1777	1585
Q Serve(g_s), s	0.1	0.0	0.1	10.2	0.0	7.1	0.2	15.1	17.8	12.0	11.6	0.1
Cycle Q Clear(g_c), s	0.2	0.0	0.1	10.3	0.0	7.1	0.2	15.1	17.8	12.0	11.6	0.1
Prop In Lane	1.00		1.00	1.00		1.00	1.00		1.00	1.00		1.00
Lane Grp Cap(c), veh/h	331	0	298	368	352	298	315	1152	514	526	1873	836
V/C Ratio(X)	0.01	0.00	0.01	0.59	0.00	0.60	0.03	0.76	0.85	0.90	0.50	0.00
Avail Cap(c_a), veh/h	418	0	413	471	488	413	428	1152	514	613	1873	836
HCM Platoon Ratio	1.00	1.00	1.00	1.00	1.00	1.00	1.00	1.00	1.00	1.00	1.00	1.00
Upstream Filter(l)	1.00	0.00	1.00	1.00	1.00	1.00	1.00	1.00	1.00	1.00	1.00	1.00
Uniform Delay (d), s/veh	22.8	0.0	22.8	27.0	22.7	25.6	15.4	20.9	21.8	14.6	10.5	7.7
Incr Delay (d2), s/veh	0.0	0.0	0.0	1.5	0.0	1.9	0.0	4.6	16.2	15.4	0.9	0.0
Initial Q Delay(d3),s/veh	0.0	0.0	0.0	0.0	0.0	0.0	0.0	0.0	0.0	0.0	0.0	0.0
%ile BackOfQ(50%),veh/ln	0.0	0.0	0.0	3.4	0.0	2.7	0.1	6.5	8.4	6.3	4.2	0.0
Unsig. Movement Delay, s/veh												
LnGrp Delay(d),s/veh	22.8	0.0	22.8	28.5	22.7	27.5	15.4	25.5	38.0	30.0	11.4	7.7
LnGrp LOS	C	A	C	C	C	C	B	C	D	C	B	A
Approach Vol, veh/h		6			397			1317			1411	
Approach Delay, s/veh		22.8			28.0			29.6			17.7	
Approach LOS		C			C			C			B	
Timer - Assigned Phs	1	2		4	5	6		8				
Phs Duration (G+Y+Rc), s	19.6	29.9		19.5	5.6	43.9		19.5				
Change Period (Y+Rc), s	5.0	7.5		6.5	5.0	7.5		6.5				
Max Green Setting (Gmax), s	18.0	14.0		18.0	5.0	27.0		18.0				
Max Q Clear Time (g_c+l1), s	14.0	19.8		2.2	2.2	13.6		12.3				
Green Ext Time (p_c), s	0.7	0.0		0.0	0.0	5.5		0.7				
Intersection Summary												
HCM 6th Ctrl Delay				24.0								
HCM 6th LOS				C								

Intersection												
Int Delay, s/veh	4.7											
Movement	EBL	EBT	EBR	WBL	WBT	WBR	NBL	NBT	NBR	SBL	SBT	SBR
Lane Configurations	↖	↑↑	↗	↖	↑↑		↖	↑	↗		↔	
Traffic Vol, veh/h	0	226	65	268	501	1	57	2	232	2	0	6
Future Vol, veh/h	0	226	65	268	501	1	57	2	232	2	0	6
Conflicting Peds, #/hr	0	0	0	0	0	0	0	0	0	0	0	0
Sign Control	Free	Free	Free	Free	Free	Free	Stop	Stop	Stop	Stop	Stop	Stop
RT Channelized	-	-	None	-	-	None	-	-	None	-	-	None
Storage Length	275	-	250	200	-	-	100	-	75	-	-	-
Veh in Median Storage, #	-	0	-	-	0	-	-	1	-	-	1	-
Grade, %	-	0	-	-	0	-	-	0	-	-	0	-
Peak Hour Factor	85	85	85	85	85	85	85	85	85	85	85	85
Heavy Vehicles, %	2	2	2	2	2	2	2	2	2	2	2	2
Mvmt Flow	0	266	76	315	589	1	67	2	273	2	0	7

Major/Minor	Major1			Major2			Minor1			Minor2		
Conflicting Flow All	590	0	0	342	0	0	1191	1486	133	1354	1562	295
Stage 1	-	-	-	-	-	-	266	266	-	1220	1220	-
Stage 2	-	-	-	-	-	-	925	1220	-	134	342	-
Critical Hdwy	4.14	-	-	4.14	-	-	7.54	6.54	6.94	7.54	6.54	6.94
Critical Hdwy Stg 1	-	-	-	-	-	-	6.54	5.54	-	6.54	5.54	-
Critical Hdwy Stg 2	-	-	-	-	-	-	6.54	5.54	-	6.54	5.54	-
Follow-up Hdwy	2.22	-	-	2.22	-	-	3.52	4.02	3.32	3.52	4.02	3.32
Pot Cap-1 Maneuver	1274	-	-	1214	-	-	143	123	892	108	111	*883
Stage 1	-	-	-	-	-	-	716	687	-	275	316	-
Stage 2	-	-	-	-	-	-	452	316	-	855	637	-
Platoon blocked, %	1	-	-	-	-	-	-	-	-	-	-	1
Mov Cap-1 Maneuver	1274	-	-	1214	-	-	113	91	892	59	82	*883
Mov Cap-2 Maneuver	-	-	-	-	-	-	250	188	-	153	160	-
Stage 1	-	-	-	-	-	-	716	687	-	275	234	-
Stage 2	-	-	-	-	-	-	332	234	-	591	637	-

Approach	EB	WB	NB	SB
HCM Control Delay, s	0	3.1	13.6	14.1
HCM LOS			B	B

Minor Lane/Major Mvmt	NBLn1	NBLn2	NBLn3	EBL	EBT	EBR	WBL	WBT	WBR	SBLn1
Capacity (veh/h)	250	188	892	1274	-	-	1214	-	-	403
HCM Lane V/C Ratio	0.268	0.013	0.306	-	-	-	0.26	-	-	0.023
HCM Control Delay (s)	24.6	24.4	10.8	0	-	-	9	-	-	14.1
HCM Lane LOS	C	C	B	A	-	-	A	-	-	B
HCM 95th %tile Q(veh)	1.1	0	1.3	0	-	-	1	-	-	0.1

Notes
 -: Volume exceeds capacity \$: Delay exceeds 300s +: Computation Not Defined *: All major volume in platoon

Intersection												
Int Delay, s/veh	1.8											
Movement	EBL	EBT	EBR	WBL	WBT	WBR	NBL	NBT	NBR	SBL	SBT	SBR
Lane Configurations	↖	↗	↘	↖	↗		↖	↗	↘		↔	
Traffic Vol, veh/h	4	552	18	53	248	11	20	1	62	10	1	7
Future Vol, veh/h	4	552	18	53	248	11	20	1	62	10	1	7
Conflicting Peds, #/hr	0	0	0	0	0	0	0	0	0	0	0	0
Sign Control	Free	Free	Free	Free	Free	Free	Stop	Stop	Stop	Stop	Stop	Stop
RT Channelized	-	-	None	-	-	None	-	-	None	-	-	None
Storage Length	275	-	250	200	-	-	100	-	75	-	-	-
Veh in Median Storage, #	-	0	-	-	0	-	-	1	-	-	1	-
Grade, %	-	0	-	-	0	-	-	0	-	-	0	-
Peak Hour Factor	94	94	94	94	94	94	94	94	94	94	94	94
Heavy Vehicles, %	2	2	2	2	2	2	2	2	2	2	2	2
Mvmt Flow	4	587	19	56	264	12	21	1	66	11	1	7

Major/Minor	Major1			Major2			Minor1			Minor2		
Conflicting Flow All	276	0	0	606	0	0	840	983	294	684	996	138
Stage 1	-	-	-	-	-	-	595	595	-	382	382	-
Stage 2	-	-	-	-	-	-	245	388	-	302	614	-
Critical Hdwy	4.14	-	-	4.14	-	-	7.54	6.54	6.94	7.54	6.54	6.94
Critical Hdwy Stg 1	-	-	-	-	-	-	6.54	5.54	-	6.54	5.54	-
Critical Hdwy Stg 2	-	-	-	-	-	-	6.54	5.54	-	6.54	5.54	-
Follow-up Hdwy	2.22	-	-	2.22	-	-	3.52	4.02	3.32	3.52	4.02	3.32
Pot Cap-1 Maneuver	1451	-	-	968	-	-	*258	247	702	335	243	*993
Stage 1	-	-	-	-	-	-	*458	491	-	774	712	-
Stage 2	-	-	-	-	-	-	*936	708	-	682	481	-
Platoon blocked, %	1	-	-	-	-	-	-	-	-	-	-	1
Mov Cap-1 Maneuver	1451	-	-	968	-	-	*244	232	702	289	228	*993
Mov Cap-2 Maneuver	-	-	-	-	-	-	*368	359	-	422	332	-
Stage 1	-	-	-	-	-	-	*457	490	-	771	671	-
Stage 2	-	-	-	-	-	-	*874	667	-	615	480	-

Approach	EB			WB			NB			SB		
HCM Control Delay, s	0.1			1.5			11.9			12		
HCM LOS							B			B		

Minor Lane/Major Mvmt	NBLn1	NBLn2	NBLn3	EBL	EBT	EBR	WBL	WBT	WBR	SBLn1
Capacity (veh/h)	368	359	702	1451	-	-	968	-	-	533
HCM Lane V/C Ratio	0.058	0.003	0.094	0.003	-	-	0.058	-	-	0.036
HCM Control Delay (s)	15.4	15.1	10.7	7.5	-	-	8.9	-	-	12
HCM Lane LOS	C	C	B	A	-	-	A	-	-	B
HCM 95th %tile Q(veh)	0.2	0	0.3	0	-	-	0.2	-	-	0.1

Notes
 -: Volume exceeds capacity \$: Delay exceeds 300s +: Computation Not Defined *: All major volume in platoon

Intersection												
Int Delay, s/veh	4.9											
Movement	EBL	EBT	EBR	WBL	WBT	WBR	NBL	NBT	NBR	SBL	SBT	SBR
Lane Configurations	↖	↑↑	↗	↖	↑↑		↖	↑	↗		↕	
Traffic Vol, veh/h	0	233	67	276	516	1	59	2	239	2	0	6
Future Vol, veh/h	0	233	67	276	516	1	59	2	239	2	0	6
Conflicting Peds, #/hr	0	0	0	0	0	0	0	0	0	0	0	0
Sign Control	Free	Free	Free	Free	Free	Free	Stop	Stop	Stop	Stop	Stop	Stop
RT Channelized	-	-	None	-	-	None	-	-	None	-	-	None
Storage Length	275	-	250	200	-	-	100	-	75	-	-	-
Veh in Median Storage, #	-	0	-	-	0	-	-	1	-	-	1	-
Grade, %	-	0	-	-	0	-	-	0	-	-	0	-
Peak Hour Factor	85	85	85	85	85	85	85	85	85	85	85	85
Heavy Vehicles, %	2	2	2	2	2	2	2	2	2	2	2	2
Mvmt Flow	0	274	79	325	607	1	69	2	281	2	0	7

Major/Minor	Major1			Major2			Minor1			Minor2		
Conflicting Flow All	608	0	0	353	0	0	1228	1532	137	1396	1611	304
Stage 1	-	-	-	-	-	-	274	274	-	1258	1258	-
Stage 2	-	-	-	-	-	-	954	1258	-	138	353	-
Critical Hdwy	4.14	-	-	4.14	-	-	7.54	6.54	6.94	7.54	6.54	6.94
Critical Hdwy Stg 1	-	-	-	-	-	-	6.54	5.54	-	6.54	5.54	-
Critical Hdwy Stg 2	-	-	-	-	-	-	6.54	5.54	-	6.54	5.54	-
Follow-up Hdwy	2.22	-	-	2.22	-	-	3.52	4.02	3.32	3.52	4.02	3.32
Pot Cap-1 Maneuver	1250	-	-	1202	-	-	134	116	886	101	103	*883
Stage 1	-	-	-	-	-	-	709	682	-	257	301	-
Stage 2	-	-	-	-	-	-	431	301	-	851	629	-
Platoon blocked, %	1	-	-	-	-	-	-	-	-	-	-	1
Mov Cap-1 Maneuver	1250	-	-	1202	-	-	105	85	886	54	75	*883
Mov Cap-2 Maneuver	-	-	-	-	-	-	237	178	-	141	149	-
Stage 1	-	-	-	-	-	-	709	682	-	257	220	-
Stage 2	-	-	-	-	-	-	312	220	-	579	629	-

Approach	EB			WB			NB			SB		
HCM Control Delay, s	0			3.2			14			14.7		
HCM LOS							B			B		

Minor Lane/Major Mvmt	NBLn1	NBLn2	NBLn3	EBL	EBT	EBR	WBL	WBT	WBR	SBLn1
Capacity (veh/h)	237	178	886	1250	-	-	1202	-	-	381
HCM Lane V/C Ratio	0.293	0.013	0.317	-	-	-	0.27	-	-	0.025
HCM Control Delay (s)	26.4	25.5	10.9	0	-	-	9.1	-	-	14.7
HCM Lane LOS	D	D	B	A	-	-	A	-	-	B
HCM 95th %tile Q(veh)	1.2	0	1.4	0	-	-	1.1	-	-	0.1

Notes
 -: Volume exceeds capacity \$: Delay exceeds 300s +: Computation Not Defined *: All major volume in platoon

Intersection												
Int Delay, s/veh	1.8											
Movement	EBL	EBT	EBR	WBL	WBT	WBR	NBL	NBT	NBR	SBL	SBT	SBR
Lane Configurations	↖	↗	↘	↖	↗		↖	↗	↘		↔	
Traffic Vol, veh/h	4	569	19	55	255	11	21	1	64	10	1	7
Future Vol, veh/h	4	569	19	55	255	11	21	1	64	10	1	7
Conflicting Peds, #/hr	0	0	0	0	0	0	0	0	0	0	0	0
Sign Control	Free	Free	Free	Free	Free	Free	Stop	Stop	Stop	Stop	Stop	Stop
RT Channelized	-	-	None	-	-	None	-	-	None	-	-	None
Storage Length	275	-	250	200	-	-	100	-	75	-	-	-
Veh in Median Storage, #	-	0	-	-	0	-	-	1	-	-	1	-
Grade, %	-	0	-	-	0	-	-	0	-	-	0	-
Peak Hour Factor	94	94	94	94	94	94	94	94	94	94	94	94
Heavy Vehicles, %	2	2	2	2	2	2	2	2	2	2	2	2
Mvmt Flow	4	605	20	59	271	12	22	1	68	11	1	7

Major/Minor	Major1			Major2			Minor1			Minor2		
Conflicting Flow All	283	0	0	625	0	0	867	1014	303	706	1028	142
Stage 1	-	-	-	-	-	-	613	613	-	395	395	-
Stage 2	-	-	-	-	-	-	254	401	-	311	633	-
Critical Hdwy	4.14	-	-	4.14	-	-	7.54	6.54	6.94	7.54	6.54	6.94
Critical Hdwy Stg 1	-	-	-	-	-	-	6.54	5.54	-	6.54	5.54	-
Critical Hdwy Stg 2	-	-	-	-	-	-	6.54	5.54	-	6.54	5.54	-
Follow-up Hdwy	2.22	-	-	2.22	-	-	3.52	4.02	3.32	3.52	4.02	3.32
Pot Cap-1 Maneuver	1442	-	-	952	-	-	247	237	693	323	233	*993
Stage 1	-	-	-	-	-	-	446	481	-	759	702	-
Stage 2	-	-	-	-	-	-	932	698	-	674	472	-
Platoon blocked, %	1	-	-	-	-	-	-	-	-	-	-	1
Mov Cap-1 Maneuver	1442	-	-	952	-	-	232	222	693	276	218	*993
Mov Cap-2 Maneuver	-	-	-	-	-	-	357	350	-	410	322	-
Stage 1	-	-	-	-	-	-	445	480	-	757	659	-
Stage 2	-	-	-	-	-	-	867	654	-	605	471	-

Approach	EB			WB			NB			SB		
HCM Control Delay, s	0.1			1.5			12.1			12.2		
HCM LOS							B			B		

Minor Lane/Major Mvmt	NBLn1	NBLn2	NBLn3	EBL	EBT	EBR	WBL	WBT	WBR	SBLn1
Capacity (veh/h)	357	350	693	1442	-	-	952	-	-	521
HCM Lane V/C Ratio	0.063	0.003	0.098	0.003	-	-	0.061	-	-	0.037
HCM Control Delay (s)	15.8	15.3	10.8	7.5	-	-	9	-	-	12.2
HCM Lane LOS	C	C	B	A	-	-	A	-	-	B
HCM 95th %tile Q(veh)	0.2	0	0.3	0	-	-	0.2	-	-	0.1

Notes
 -: Volume exceeds capacity \$: Delay exceeds 300s +: Computation Not Defined *: All major volume in platoon

Intersection												
Int Delay, s/veh	4.8											
Movement	EBL	EBT	EBR	WBL	WBT	WBR	NBL	NBT	NBR	SBL	SBT	SBR
Lane Configurations	↖	↗	↘	↖	↗		↖	↗	↘		↔	
Traffic Vol, veh/h	0	264	67	285	604	1	59	2	242	2	0	6
Future Vol, veh/h	0	264	67	285	604	1	59	2	242	2	0	6
Conflicting Peds, #/hr	0	0	0	0	0	0	0	0	0	0	0	0
Sign Control	Free	Free	Free	Free	Free	Free	Stop	Stop	Stop	Stop	Stop	Stop
RT Channelized	-	-	None	-	-	None	-	-	None	-	-	None
Storage Length	275	-	250	200	-	-	100	-	75	-	-	-
Veh in Median Storage, #	-	0	-	-	0	-	-	1	-	-	1	-
Grade, %	-	0	-	-	0	-	-	0	-	-	0	-
Peak Hour Factor	85	85	85	85	85	85	85	85	85	85	85	85
Heavy Vehicles, %	2	2	2	2	2	2	2	2	2	2	2	2
Mvmt Flow	0	311	79	335	711	1	69	2	285	2	0	7

Major/Minor	Major1			Major2			Minor1			Minor2		
Conflicting Flow All	712	0	0	390	0	0	1337	1693	156	1539	1772	356
Stage 1	-	-	-	-	-	-	311	311	-	1382	1382	-
Stage 2	-	-	-	-	-	-	1026	1382	-	157	390	-
Critical Hdwy	4.14	-	-	4.14	-	-	7.54	6.54	6.94	7.54	6.54	6.94
Critical Hdwy Stg 1	-	-	-	-	-	-	6.54	5.54	-	6.54	5.54	-
Critical Hdwy Stg 2	-	-	-	-	-	-	6.54	5.54	-	6.54	5.54	-
Follow-up Hdwy	2.22	-	-	2.22	-	-	3.52	4.02	3.32	3.52	4.02	3.32
Pot Cap-1 Maneuver	1173	-	-	1165	-	-	111	92	862	79	82	*856
Stage 1	-	-	-	-	-	-	674	657	-	220	265	-
Stage 2	-	-	-	-	-	-	411	265	-	829	606	-
Platoon blocked, %	1	-	-	-	-	-	-	-	-	-	-	1
Mov Cap-1 Maneuver	1173	-	-	1165	-	-	86	66	862	41	58	*856
Mov Cap-2 Maneuver	-	-	-	-	-	-	217	153	-	119	127	-
Stage 1	-	-	-	-	-	-	674	657	-	220	189	-
Stage 2	-	-	-	-	-	-	290	189	-	553	606	-

Approach	EB	WB	NB	SB
HCM Control Delay, s	0	3	14.8	16
HCM LOS			B	C

Minor Lane/Major Mvmt	NBLn1	NBLn2	NBLn3	EBL	EBT	EBR	WBL	WBT	WBR	SBLn1
Capacity (veh/h)	217	153	862	1173	-	-	1165	-	-	336
HCM Lane V/C Ratio	0.32	0.015	0.33	-	-	-	0.288	-	-	0.028
HCM Control Delay (s)	29.2	28.9	11.2	0	-	-	9.3	-	-	16
HCM Lane LOS	D	D	B	A	-	-	A	-	-	C
HCM 95th %tile Q(veh)	1.3	0	1.4	0	-	-	1.2	-	-	0.1

Notes
 -: Volume exceeds capacity \$: Delay exceeds 300s +: Computation Not Defined *: All major volume in platoon

Intersection												
Int Delay, s/veh	1.7											
Movement	EBL	EBT	EBR	WBL	WBT	WBR	NBL	NBT	NBR	SBL	SBT	SBR
Lane Configurations	↖	↗	↘	↖	↗		↖	↗	↘		↔	
Traffic Vol, veh/h	4	674	19	61	316	11	21	1	74	10	1	7
Future Vol, veh/h	4	674	19	61	316	11	21	1	74	10	1	7
Conflicting Peds, #/hr	0	0	0	0	0	0	0	0	0	0	0	0
Sign Control	Free	Free	Free	Free	Free	Free	Stop	Stop	Stop	Stop	Stop	Stop
RT Channelized	-	-	None	-	-	None	-	-	None	-	-	None
Storage Length	275	-	250	200	-	-	100	-	75	-	-	-
Veh in Median Storage, #	-	0	-	-	0	-	-	1	-	-	1	-
Grade, %	-	0	-	-	0	-	-	0	-	-	0	-
Peak Hour Factor	94	94	94	94	94	94	94	94	94	94	94	94
Heavy Vehicles, %	2	2	2	2	2	2	2	2	2	2	2	2
Mvmt Flow	4	717	20	65	336	12	22	1	79	11	1	7

Major/Minor	Major1			Major2			Minor1			Minor2		
Conflicting Flow All	348	0	0	737	0	0	1024	1203	359	839	1217	174
Stage 1	-	-	-	-	-	-	725	725	-	472	472	-
Stage 2	-	-	-	-	-	-	299	478	-	367	745	-
Critical Hdwy	4.14	-	-	4.14	-	-	7.54	6.54	6.94	7.54	6.54	6.94
Critical Hdwy Stg 1	-	-	-	-	-	-	6.54	5.54	-	6.54	5.54	-
Critical Hdwy Stg 2	-	-	-	-	-	-	6.54	5.54	-	6.54	5.54	-
Follow-up Hdwy	2.22	-	-	2.22	-	-	3.52	4.02	3.32	3.52	4.02	3.32
Pot Cap-1 Maneuver	1416	-	-	865	-	-	*190	183	638	259	180	*965
Stage 1	-	-	-	-	-	-	*383	428	-	733	678	-
Stage 2	-	-	-	-	-	-	*910	674	-	625	419	-
Platoon blocked, %	1	-	-	-	-	-	-	-	-	-	-	1
Mov Cap-1 Maneuver	1416	-	-	865	-	-	*177	169	638	213	166	*965
Mov Cap-2 Maneuver	-	-	-	-	-	-	*304	304	-	355	273	-
Stage 1	-	-	-	-	-	-	*382	427	-	731	627	-
Stage 2	-	-	-	-	-	-	*834	623	-	545	418	-

Approach	EB			WB			NB			SB		
HCM Control Delay, s	0			1.5			12.9			13.1		
HCM LOS							B			B		

Minor Lane/Major Mvmt	NBLn1	NBLn2	NBLn3	EBL	EBT	EBR	WBL	WBT	WBR	SBLn1
Capacity (veh/h)	304	304	638	1416	-	-	865	-	-	461
HCM Lane V/C Ratio	0.073	0.003	0.123	0.003	-	-	0.075	-	-	0.042
HCM Control Delay (s)	17.8	16.9	11.4	7.5	-	-	9.5	-	-	13.1
HCM Lane LOS	C	C	B	A	-	-	A	-	-	B
HCM 95th %tile Q(veh)	0.2	0	0.4	0	-	-	0.2	-	-	0.1

Notes
 -: Volume exceeds capacity \$: Delay exceeds 300s +: Computation Not Defined *: All major volume in platoon

Intersection												
Int Delay, s/veh	7.4											
Movement	EBL	EBT	EBR	WBL	WBT	WBR	NBL	NBT	NBR	SBL	SBT	SBR
Lane Configurations	↘	↑↑	↗	↘	↑↑		↘	↑	↗		↔	
Traffic Vol, veh/h	0	314	90	372	695	1	79	2	322	2	0	6
Future Vol, veh/h	0	314	90	372	695	1	79	2	322	2	0	6
Conflicting Peds, #/hr	0	0	0	0	0	0	0	0	0	0	0	0
Sign Control	Free	Free	Free	Free	Free	Free	Stop	Stop	Stop	Stop	Stop	Stop
RT Channelized	-	-	None	-	-	None	-	-	None	-	-	None
Storage Length	275	-	250	200	-	-	100	-	75	-	-	-
Veh in Median Storage, #	-	0	-	-	0	-	-	1	-	-	1	-
Grade, %	-	0	-	-	0	-	-	0	-	-	0	-
Peak Hour Factor	85	85	85	85	85	85	85	85	85	85	85	85
Heavy Vehicles, %	2	2	2	2	2	2	2	2	2	2	2	2
Mvmt Flow	0	369	106	438	818	1	93	2	379	2	0	7

Major/Minor	Major1			Major2			Minor1			Minor2		
Conflicting Flow All	819	0	0	475	0	0	1654	2064	185	1881	2170	410
Stage 1	-	-	-	-	-	-	369	369	-	1695	1695	-
Stage 2	-	-	-	-	-	-	1285	1695	-	186	475	-
Critical Hdwy	4.14	-	-	4.14	-	-	7.54	6.54	6.94	7.54	6.54	6.94
Critical Hdwy Stg 1	-	-	-	-	-	-	6.54	5.54	-	6.54	5.54	-
Critical Hdwy Stg 2	-	-	-	-	-	-	6.54	5.54	-	6.54	5.54	-
Follow-up Hdwy	2.22	-	-	2.22	-	-	3.52	4.02	3.32	3.52	4.02	3.32
Pot Cap-1 Maneuver	1149	-	-	1083	-	-	~ 65	54	826	44	46	*801
Stage 1	-	-	-	-	-	-	623	619	-	138	183	-
Stage 2	-	-	-	-	-	-	301	183	-	798	556	-
Platoon blocked, %	1	-	-	-	-	-	-	-	-	-	-	1
Mov Cap-1 Maneuver	1149	-	-	1083	-	-	~ 44	32	826	16	27	*801
Mov Cap-2 Maneuver	-	-	-	-	-	-	139	91	-	~ -13	64	-
Stage 1	-	-	-	-	-	-	623	619	-	138	109	-
Stage 2	-	-	-	-	-	-	178	109	-	430	556	-

Approach	EB	WB	NB	SB
HCM Control Delay, s	0	3.7	24.7	
HCM LOS			C	-

Minor Lane/Major Mvmt	NBLn1	NBLn2	NBLn3	EBL	EBT	EBR	WBL	WBT	WBR	SBLn1
Capacity (veh/h)	139	91	826	1149	-	-	1083	-	-	+
HCM Lane V/C Ratio	0.669	0.026	0.459	-	-	-	0.404	-	-	-
HCM Control Delay (s)	71.9	45.6	13	0	-	-	10.6	-	-	-
HCM Lane LOS	F	E	B	A	-	-	B	-	-	-
HCM 95th %tile Q(veh)	3.7	0.1	2.4	0	-	-	2	-	-	-

Notes
 -: Volume exceeds capacity \$: Delay exceeds 300s +: Computation Not Defined *: All major volume in platoon

Intersection												
Int Delay, s/veh	1.9											
Movement	EBL	EBT	EBR	WBL	WBT	WBR	NBL	NBT	NBR	SBL	SBT	SBR
Lane Configurations	↙	↑↑	↗	↙	↑↑		↙	↑	↗		↔	
Traffic Vol, veh/h	4	766	25	74	344	11	28	1	86	10	1	7
Future Vol, veh/h	4	766	25	74	344	11	28	1	86	10	1	7
Conflicting Peds, #/hr	0	0	0	0	0	0	0	0	0	0	0	0
Sign Control	Free	Free	Free	Free	Free	Free	Stop	Stop	Stop	Stop	Stop	Stop
RT Channelized	-	-	None	-	-	None	-	-	None	-	-	None
Storage Length	275	-	250	200	-	-	100	-	75	-	-	-
Veh in Median Storage, #	-	0	-	-	0	-	-	1	-	-	1	-
Grade, %	-	0	-	-	0	-	-	0	-	-	0	-
Peak Hour Factor	94	94	94	94	94	94	94	94	94	94	94	94
Heavy Vehicles, %	2	2	2	2	2	2	2	2	2	2	2	2
Mvmt Flow	4	815	27	79	366	12	30	1	91	11	1	7

Major/Minor	Major1			Major2			Minor1			Minor2		
Conflicting Flow All	378	0	0	842	0	0	1165	1359	408	946	1380	189
Stage 1	-	-	-	-	-	-	823	823	-	530	530	-
Stage 2	-	-	-	-	-	-	342	536	-	416	850	-
Critical Hdwy	4.14	-	-	4.14	-	-	7.54	6.54	6.94	7.54	6.54	6.94
Critical Hdwy Stg 1	-	-	-	-	-	-	6.54	5.54	-	6.54	5.54	-
Critical Hdwy Stg 2	-	-	-	-	-	-	6.54	5.54	-	6.54	5.54	-
Follow-up Hdwy	2.22	-	-	2.22	-	-	3.52	4.02	3.32	3.52	4.02	3.32
Pot Cap-1 Maneuver	1376	-	-	789	-	-	149	147	593	216	143	*965
Stage 1	-	-	-	-	-	-	334	386	-	671	636	-
Stage 2	-	-	-	-	-	-	890	632	-	585	375	-
Platoon blocked, %	1	-	-	-	-	-	-	-	-	-	-	1
Mov Cap-1 Maneuver	1376	-	-	789	-	-	136	132	593	168	128	*965
Mov Cap-2 Maneuver	-	-	-	-	-	-	262	266	-	304	228	-
Stage 1	-	-	-	-	-	-	333	385	-	669	572	-
Stage 2	-	-	-	-	-	-	793	569	-	492	374	-

Approach	EB	WB	NB	SB
HCM Control Delay, s	0	1.7	14.3	14.4
HCM LOS			B	B

Minor Lane/Major Mvmt	NBLn1	NBLn2	NBLn3	EBL	EBT	EBR	WBL	WBT	WBR	SBLn1
Capacity (veh/h)	262	266	593	1376	-	-	789	-	-	404
HCM Lane V/C Ratio	0.114	0.004	0.154	0.003	-	-	0.1	-	-	0.047
HCM Control Delay (s)	20.5	18.6	12.2	7.6	-	-	10.1	-	-	14.4
HCM Lane LOS	C	C	B	A	-	-	B	-	-	B
HCM 95th %tile Q(veh)	0.4	0	0.5	0	-	-	0.3	-	-	0.1

Notes
 -: Volume exceeds capacity \$: Delay exceeds 300s +: Computation Not Defined *: All major volume in platoon

Intersection												
Int Delay, s/veh	7.8											
Movement	EBL	EBT	EBR	WBL	WBT	WBR	NBL	NBT	NBR	SBL	SBT	SBR
Lane Configurations	↖	↑↑	↗	↖	↑↑		↖	↑	↗		↕	
Traffic Vol, veh/h	0	345	90	381	783	1	79	2	325	2	0	6
Future Vol, veh/h	0	345	90	381	783	1	79	2	325	2	0	6
Conflicting Peds, #/hr	0	0	0	0	0	0	0	0	0	0	0	0
Sign Control	Free	Free	Free	Free	Free	Free	Stop	Stop	Stop	Stop	Stop	Stop
RT Channelized	-	-	None	-	-	None	-	-	None	-	-	None
Storage Length	275	-	250	200	-	-	100	-	75	-	-	-
Veh in Median Storage, #	-	0	-	-	0	-	-	1	-	-	1	-
Grade, %	-	0	-	-	0	-	-	0	-	-	0	-
Peak Hour Factor	85	85	85	85	85	85	85	85	85	85	85	85
Heavy Vehicles, %	2	2	2	2	2	2	2	2	2	2	2	2
Mvmt Flow	0	406	106	448	921	1	93	2	382	2	0	7

Major/Minor	Major1			Major2			Minor1			Minor2		
Conflicting Flow All	922	0	0	512	0	0	1763	2224	203	2022	2330	461
Stage 1	-	-	-	-	-	-	406	406	-	1818	1818	-
Stage 2	-	-	-	-	-	-	1357	1818	-	204	512	-
Critical Hdwy	4.14	-	-	4.14	-	-	7.54	6.54	6.94	7.54	6.54	6.94
Critical Hdwy Stg 1	-	-	-	-	-	-	6.54	5.54	-	6.54	5.54	-
Critical Hdwy Stg 2	-	-	-	-	-	-	6.54	5.54	-	6.54	5.54	-
Follow-up Hdwy	2.22	-	-	2.22	-	-	3.52	4.02	3.32	3.52	4.02	3.32
Pot Cap-1 Maneuver	1073	-	-	1050	-	-	~ 53	43	804	34	37	*773
Stage 1	-	-	-	-	-	-	593	596	-	114	156	-
Stage 2	-	-	-	-	-	-	283	156	-	779	535	-
Platoon blocked, %	1	-	-	-	-	-	-	-	-	-	-	1
Mov Cap-1 Maneuver	1073	-	-	1050	-	-	~ 35	25	804	12	21	*773
Mov Cap-2 Maneuver	-	-	-	-	-	-	126	75	-	~ -90	50	-
Stage 1	-	-	-	-	-	-	593	596	-	114	89	-
Stage 2	-	-	-	-	-	-	161	89	-	407	535	-

Approach	EB			WB			NB			SB		
HCM Control Delay, s	0			3.6			28.3					
HCM LOS							D					

Minor Lane/Major Mvmt	NBLn1	NBLn2	NBLn3	EBL	EBT	EBR	WBL	WBT	WBR	SBLn1
Capacity (veh/h)	126	75	804	1073	-	-	1050	-	-	+
HCM Lane V/C Ratio	0.738	0.031	0.476	-	-	-	0.427	-	-	-
HCM Control Delay (s)	88.4	54.5	13.5	0	-	-	11	-	-	-
HCM Lane LOS	F	F	B	A	-	-	B	-	-	-
HCM 95th %tile Q(veh)	4.2	0.1	2.6	0	-	-	2.2	-	-	-

Notes
 -: Volume exceeds capacity \$: Delay exceeds 300s +: Computation Not Defined *: All major volume in platoon

Intersection												
Int Delay, s/veh	2											
Movement	EBL	EBT	EBR	WBL	WBT	WBR	NBL	NBT	NBR	SBL	SBT	SBR
Lane Configurations	↖	↑↑	↗	↖	↑↑		↖	↑	↗		↔	
Traffic Vol, veh/h	4	871	25	80	405	11	28	1	96	10	1	7
Future Vol, veh/h	4	871	25	80	405	11	28	1	96	10	1	7
Conflicting Peds, #/hr	0	0	0	0	0	0	0	0	0	0	0	0
Sign Control	Free	Free	Free	Free	Free	Free	Stop	Stop	Stop	Stop	Stop	Stop
RT Channelized	-	-	None	-	-	None	-	-	None	-	-	None
Storage Length	275	-	250	200	-	-	100	-	75	-	-	-
Veh in Median Storage, #	-	0	-	-	0	-	-	1	-	-	1	-
Grade, %	-	0	-	-	0	-	-	0	-	-	0	-
Peak Hour Factor	94	94	94	94	94	94	94	94	94	94	94	94
Heavy Vehicles, %	2	2	2	2	2	2	2	2	2	2	2	2
Mvmt Flow	4	927	27	85	431	12	30	1	102	11	1	7

Major/Minor	Major1			Major2			Minor1			Minor2		
Conflicting Flow All	443	0	0	954	0	0	1321	1548	464	1079	1569	222
Stage 1	-	-	-	-	-	-	935	935	-	607	607	-
Stage 2	-	-	-	-	-	-	386	613	-	472	962	-
Critical Hdwy	4.14	-	-	4.14	-	-	7.54	6.54	6.94	7.54	6.54	6.94
Critical Hdwy Stg 1	-	-	-	-	-	-	6.54	5.54	-	6.54	5.54	-
Critical Hdwy Stg 2	-	-	-	-	-	-	6.54	5.54	-	6.54	5.54	-
Follow-up Hdwy	2.22	-	-	2.22	-	-	3.52	4.02	3.32	3.52	4.02	3.32
Pot Cap-1 Maneuver	1349	-	-	716	-	-	*115	113	545	173	110	*938
Stage 1	-	-	-	-	-	-	*285	342	-	645	613	-
Stage 2	-	-	-	-	-	-	*884	609	-	542	332	-
Platoon blocked, %	1	-	-	-	-	-	-	-	-	-	-	1
Mov Cap-1 Maneuver	1349	-	-	716	-	-	*103	99	545	127	97	*938
Mov Cap-2 Maneuver	-	-	-	-	-	-	*224	232	-	259	190	-
Stage 1	-	-	-	-	-	-	*284	341	-	643	540	-
Stage 2	-	-	-	-	-	-	*772	536	-	438	331	-

Approach	EB	WB	NB	SB
HCM Control Delay, s	0	1.7	15.5	15.8
HCM LOS			C	C

Minor Lane/Major Mvmt	NBLn1	NBLn2	NBLn3	EBL	EBT	EBR	WBL	WBT	WBR	SBLn1
Capacity (veh/h)	224	232	545	1349	-	-	716	-	-	351
HCM Lane V/C Ratio	0.133	0.005	0.187	0.003	-	-	0.119	-	-	0.055
HCM Control Delay (s)	23.5	20.6	13.1	7.7	-	-	10.7	-	-	15.8
HCM Lane LOS	C	C	B	A	-	-	B	-	-	C
HCM 95th %tile Q(veh)	0.5	0	0.7	0	-	-	0.4	-	-	0.2

Notes
 -: Volume exceeds capacity \$: Delay exceeds 300s +: Computation Not Defined *: All major volume in platoon

Timings
3: Chapel Ridge Dr & Old Ranch Rd

2023 Existing AM
09/06/2023

Lane Group	EBL	EBT	EBR	WBL	WBT	WBR	NBL	NBT	NBR	SBL	SBT	SBR
Lane Configurations												
Traffic Volume (vph)	23	385	52	110	667	12	66	7	155	48	10	72
Future Volume (vph)	23	385	52	110	667	12	66	7	155	48	10	72
Turn Type	pm+pt	NA	Perm	pm+pt	NA	Perm	pm+pt	NA	Perm	pm+pt	NA	Perm
Protected Phases	5	2		1	6		7	4		3	8	
Permitted Phases	2		2	6		6	4		4	8		8
Detector Phase	5	2	2	1	6	6	7	4	4	3	8	8
Switch Phase												
Minimum Initial (s)	4.0	6.0	6.0	4.0	6.0	6.0	4.0	4.0	4.0	4.0	4.0	4.0
Minimum Split (s)	10.0	24.0	24.0	10.0	24.0	24.0	10.5	24.5	24.5	10.5	24.5	24.5
Total Split (s)	14.0	56.0	56.0	14.0	56.0	56.0	17.0	27.0	27.0	17.0	27.0	27.0
Total Split (%)	12.3%	49.1%	49.1%	12.3%	49.1%	49.1%	14.9%	23.7%	23.7%	14.9%	23.7%	23.7%
Yellow Time (s)	4.0	4.0	4.0	4.0	4.0	4.0	4.5	4.5	4.5	4.5	4.5	4.5
All-Red Time (s)	2.0	2.0	2.0	2.0	2.0	2.0	2.0	2.0	2.0	2.0	2.0	2.0
Lost Time Adjust (s)	0.0	0.0	0.0	0.0	0.0	0.0	0.0	0.0	0.0	0.0	0.0	0.0
Total Lost Time (s)	6.0	6.0	6.0	6.0	6.0	6.0	6.5	6.5	6.5	6.5	6.5	6.5
Lead/Lag	Lead	Lag	Lag	Lead	Lag	Lag	Lead	Lag	Lag	Lead	Lag	Lag
Lead-Lag Optimize?	Yes	Yes	Yes	Yes	Yes	Yes	Yes	Yes	Yes	Yes	Yes	Yes
Recall Mode	None	C-Max	C-Max	None	C-Max	C-Max	None	Max	Max	None	Max	Max
Act Effct Green (s)	56.6	50.2	50.2	61.1	56.3	56.3	32.9	25.3	25.3	31.7	24.7	24.7
Actuated g/C Ratio	0.50	0.44	0.44	0.54	0.49	0.49	0.29	0.22	0.22	0.28	0.22	0.22
v/c Ratio	0.09	0.31	0.08	0.29	0.48	0.02	0.20	0.01	0.39	0.14	0.02	0.20
Control Delay	12.1	21.4	0.2	24.6	34.3	0.0	28.5	38.0	8.1	27.9	38.4	1.8
Queue Delay	0.0	0.0	0.0	0.0	0.0	0.0	0.0	0.0	0.0	0.0	0.0	0.0
Total Delay	12.1	21.4	0.2	24.6	34.3	0.0	28.5	38.0	8.1	27.9	38.4	1.8
LOS	B	C	A	C	C	A	C	D	A	C	D	A
Approach Delay		18.5			32.4			15.0			14.3	
Approach LOS		B			C			B			B	

Intersection Summary

Cycle Length: 114
 Actuated Cycle Length: 114
 Offset: 33 (29%), Referenced to phase 2:EBTL and 6:WBTL, Start of Green
 Natural Cycle: 70
 Control Type: Actuated-Coordinated
 Maximum v/c Ratio: 0.48
 Intersection Signal Delay: 24.5
 Intersection LOS: C
 Intersection Capacity Utilization 47.5%
 ICU Level of Service A
 Analysis Period (min) 15

Splits and Phases: 3: Chapel Ridge Dr & Old Ranch Rd

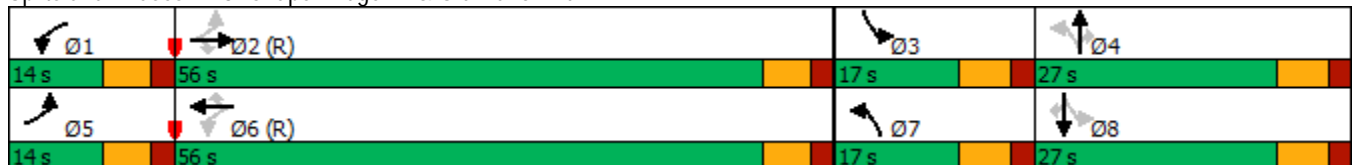

HCM 6th Signalized Intersection Summary
3: Chapel Ridge Dr & Old Ranch Rd

2023 Existing AM
09/06/2023



Movement	EBL	EBT	EBR	WBL	WBT	WBR	NBL	NBT	NBR	SBL	SBT	SBR
Lane Configurations	↘	↗	↘	↘	↗	↘	↘	↗	↘	↘	↗	↘
Traffic Volume (veh/h)	23	385	52	110	667	12	66	7	155	48	10	72
Future Volume (veh/h)	23	385	52	110	667	12	66	7	155	48	10	72
Initial Q (Qb), veh	0	0	0	0	0	0	0	0	0	0	0	0
Ped-Bike Adj(A_pbT)	1.00		1.00	1.00		1.00	1.00		1.00	1.00		1.00
Parking Bus, Adj	1.00	1.00	1.00	1.00	1.00	1.00	1.00	1.00	1.00	1.00	1.00	1.00
Work Zone On Approach		No			No			No			No	
Adj Sat Flow, veh/h/ln	1870	1870	1870	1870	1870	1870	1870	1870	1870	1870	1870	1870
Adj Flow Rate, veh/h	29	481	65	138	834	15	82	9	194	60	12	90
Peak Hour Factor	0.80	0.80	0.80	0.80	0.80	0.80	0.80	0.80	0.80	0.80	0.80	0.80
Percent Heavy Veh, %	2	2	2	2	2	2	2	2	2	2	2	2
Cap, veh/h	327	1759	785	519	1879	838	383	684	305	344	639	285
Arrive On Green	0.02	0.50	0.50	0.04	0.35	0.35	0.05	0.19	0.19	0.04	0.18	0.18
Sat Flow, veh/h	1781	3554	1585	1781	3554	1585	1781	3554	1585	1781	3554	1585
Grp Volume(v), veh/h	29	481	65	138	834	15	82	9	194	60	12	90
Grp Sat Flow(s),veh/h/ln	1781	1777	1585	1781	1777	1585	1781	1777	1585	1781	1777	1585
Q Serve(g_s), s	0.9	9.0	2.5	4.3	20.5	0.7	4.2	0.2	12.8	3.1	0.3	5.6
Cycle Q Clear(g_c), s	0.9	9.0	2.5	4.3	20.5	0.7	4.2	0.2	12.8	3.1	0.3	5.6
Prop In Lane	1.00		1.00	1.00		1.00	1.00		1.00	1.00		1.00
Lane Grp Cap(c), veh/h	327	1759	785	519	1879	838	383	684	305	344	639	285
V/C Ratio(X)	0.09	0.27	0.08	0.27	0.44	0.02	0.21	0.01	0.64	0.17	0.02	0.32
Avail Cap(c_a), veh/h	415	1759	785	546	1879	838	456	684	305	439	639	285
HCM Platoon Ratio	1.00	1.00	1.00	0.67	0.67	0.67	1.00	1.00	1.00	1.00	1.00	1.00
Upstream Filter(I)	1.00	1.00	1.00	0.94	0.94	0.94	1.00	1.00	1.00	1.00	1.00	1.00
Uniform Delay (d), s/veh	14.8	16.8	15.2	13.2	24.0	17.6	35.3	37.3	42.4	36.1	38.5	40.7
Incr Delay (d2), s/veh	0.1	0.4	0.2	0.3	0.7	0.0	0.3	0.0	9.7	0.2	0.1	2.9
Initial Q Delay(d3),s/veh	0.0	0.0	0.0	0.0	0.0	0.0	0.0	0.0	0.0	0.0	0.0	0.0
%ile BackOfQ(50%),veh/ln	0.4	3.7	0.9	1.8	9.4	0.3	1.9	0.1	5.8	1.4	0.1	2.4
Unsig. Movement Delay, s/veh												
LnGrp Delay(d),s/veh	15.0	17.2	15.4	13.4	24.7	17.6	35.6	37.3	52.1	36.3	38.5	43.5
LnGrp LOS	B	B	B	B	C	B	D	D	D	D	D	D
Approach Vol, veh/h		575			987			285			162	
Approach Delay, s/veh		16.9			23.0			46.9			40.5	
Approach LOS		B			C			D			D	
Timer - Assigned Phs	1	2	3	4	5	6	7	8				
Phs Duration (G+Y+Rc), s	12.2	62.4	10.9	28.4	8.4	66.3	12.3	27.0				
Change Period (Y+Rc), s	6.0	6.0	6.5	6.5	6.0	6.0	6.5	6.5				
Max Green Setting (Gmax), s	8.0	50.0	10.5	20.5	8.0	50.0	10.5	20.5				
Max Q Clear Time (g_c+I1), s	6.3	11.0	5.1	14.8	2.9	22.5	6.2	7.6				
Green Ext Time (p_c), s	0.1	3.8	0.0	0.3	0.0	6.6	0.1	0.2				
Intersection Summary												
HCM 6th Ctrl Delay				26.0								
HCM 6th LOS				C								

Timings
3: Chapel Ridge Dr & Old Ranch Rd

2023 Existing PM
09/06/2023

Lane Group	EBL	EBT	EBR	WBL	WBT	WBR	NBL	NBT	NBR	SBL	SBT	SBR
Lane Configurations												
Traffic Volume (vph)	70	409	49	80	219	20	37	16	80	25	6	34
Future Volume (vph)	70	409	49	80	219	20	37	16	80	25	6	34
Turn Type	pm+pt	NA	Perm	pm+pt	NA	Perm	pm+pt	NA	Perm	pm+pt	NA	Perm
Protected Phases	5	2		1	6		7	4		3	8	
Permitted Phases	2		2	6		6	4		4	8		8
Detector Phase	5	2	2	1	6	6	7	4	4	3	8	8
Switch Phase												
Minimum Initial (s)	4.0	6.0	6.0	4.0	6.0	6.0	4.0	4.0	4.0	4.0	4.0	4.0
Minimum Split (s)	10.0	24.0	24.0	10.0	24.0	24.0	10.5	24.5	24.5	10.5	24.5	24.5
Total Split (s)	14.0	56.0	56.0	14.0	56.0	56.0	17.0	27.0	27.0	17.0	27.0	27.0
Total Split (%)	12.3%	49.1%	49.1%	12.3%	49.1%	49.1%	14.9%	23.7%	23.7%	14.9%	23.7%	23.7%
Yellow Time (s)	4.0	4.0	4.0	4.0	4.0	4.0	4.5	4.5	4.5	4.5	4.5	4.5
All-Red Time (s)	2.0	2.0	2.0	2.0	2.0	2.0	2.0	2.0	2.0	2.0	2.0	2.0
Lost Time Adjust (s)	0.0	0.0	0.0	0.0	0.0	0.0	0.0	0.0	0.0	0.0	0.0	0.0
Total Lost Time (s)	6.0	6.0	6.0	6.0	6.0	6.0	6.5	6.5	6.5	6.5	6.5	6.5
Lead/Lag	Lead	Lag	Lag	Lead	Lag	Lag	Lead	Lag	Lag	Lead	Lag	Lag
Lead-Lag Optimize?	Yes	Yes	Yes	Yes	Yes	Yes	Yes	Yes	Yes	Yes	Yes	Yes
Recall Mode	None	C-Max	C-Max	None	C-Max	C-Max	None	Max	Max	None	Max	Max
Act Effct Green (s)	59.1	53.0	53.0	59.3	53.1	53.1	34.0	29.2	29.2	33.2	28.8	28.8
Actuated g/C Ratio	0.52	0.46	0.46	0.52	0.47	0.47	0.30	0.26	0.26	0.29	0.25	0.25
v/c Ratio	0.11	0.25	0.06	0.16	0.13	0.02	0.08	0.02	0.16	0.06	0.01	0.07
Control Delay	12.1	19.8	0.1	11.3	15.8	0.1	27.1	35.9	0.7	26.8	36.8	0.3
Queue Delay	0.0	0.0	0.0	0.0	0.0	0.0	0.0	0.0	0.0	0.0	0.0	0.0
Total Delay	12.1	19.8	0.1	11.3	15.8	0.1	27.1	35.9	0.7	26.8	36.8	0.3
LOS	B	B	A	B	B	A	C	D	A	C	D	A
Approach Delay		16.9			13.7			12.2			13.8	
Approach LOS		B			B			B			B	

Intersection Summary

Cycle Length: 114
 Actuated Cycle Length: 114
 Offset: 33 (29%), Referenced to phase 2:EBTL and 6:WBTL, Start of Green
 Natural Cycle: 70
 Control Type: Actuated-Coordinated
 Maximum v/c Ratio: 0.25
 Intersection Signal Delay: 15.1
 Intersection LOS: B
 Intersection Capacity Utilization 39.9%
 ICU Level of Service A
 Analysis Period (min) 15

Splits and Phases: 3: Chapel Ridge Dr & Old Ranch Rd



HCM 6th Signalized Intersection Summary
3: Chapel Ridge Dr & Old Ranch Rd

2023 Existing PM
09/06/2023



Movement	EBL	EBT	EBR	WBL	WBT	WBR	NBL	NBT	NBR	SBL	SBT	SBR
Lane Configurations												
Traffic Volume (veh/h)	70	409	49	80	219	20	37	16	80	25	6	34
Future Volume (veh/h)	70	409	49	80	219	20	37	16	80	25	6	34
Initial Q (Qb), veh	0	0	0	0	0	0	0	0	0	0	0	0
Ped-Bike Adj(A_pbT)	1.00		1.00	1.00		1.00	1.00		1.00	1.00		1.00
Parking Bus, Adj	1.00	1.00	1.00	1.00	1.00	1.00	1.00	1.00	1.00	1.00	1.00	1.00
Work Zone On Approach		No			No			No			No	
Adj Sat Flow, veh/h/ln	1870	1870	1870	1870	1870	1870	1870	1870	1870	1870	1870	1870
Adj Flow Rate, veh/h	71	413	49	81	221	20	37	16	81	25	6	34
Peak Hour Factor	0.99	0.99	0.99	0.99	0.99	0.99	0.99	0.99	0.99	0.99	0.99	0.99
Percent Heavy Veh, %	2	2	2	2	2	2	2	2	2	2	2	2
Cap, veh/h	681	1925	858	573	1936	864	350	657	293	331	639	285
Arrive On Green	0.03	0.54	0.54	0.01	0.18	0.18	0.02	0.18	0.18	0.02	0.18	0.18
Sat Flow, veh/h	1781	3554	1585	1781	3554	1585	1781	3554	1585	1781	3554	1585
Grp Volume(v), veh/h	71	413	49	81	221	20	37	16	81	25	6	34
Grp Sat Flow(s),veh/h/ln	1781	1777	1585	1781	1777	1585	1781	1777	1585	1781	1777	1585
Q Serve(g_s), s	2.0	6.9	1.7	2.3	5.9	1.2	1.9	0.4	5.0	1.3	0.2	2.0
Cycle Q Clear(g_c), s	2.0	6.9	1.7	2.3	5.9	1.2	1.9	0.4	5.0	1.3	0.2	2.0
Prop In Lane	1.00		1.00	1.00		1.00	1.00		1.00	1.00		1.00
Lane Grp Cap(c), veh/h	681	1925	858	573	1936	864	350	657	293	331	639	285
V/C Ratio(X)	0.10	0.21	0.06	0.14	0.11	0.02	0.11	0.02	0.28	0.08	0.01	0.12
Avail Cap(c_a), veh/h	749	1925	858	636	1936	864	471	657	293	461	639	285
HCM Platoon Ratio	1.00	1.00	1.00	0.33	0.33	0.33	1.00	1.00	1.00	1.00	1.00	1.00
Upstream Filter(I)	1.00	1.00	1.00	1.00	1.00	1.00	1.00	1.00	1.00	1.00	1.00	1.00
Uniform Delay (d), s/veh	10.9	13.6	12.4	11.2	23.7	21.8	36.9	38.0	39.9	37.1	38.4	39.2
Incr Delay (d2), s/veh	0.1	0.3	0.1	0.1	0.1	0.0	0.1	0.1	2.3	0.1	0.0	0.9
Initial Q Delay(d3),s/veh	0.0	0.0	0.0	0.0	0.0	0.0	0.0	0.0	0.0	0.0	0.0	0.0
%ile BackOfQ(50%),veh/ln	0.8	2.8	0.6	0.9	2.6	0.4	0.9	0.2	2.1	0.6	0.1	0.9
Unsig. Movement Delay, s/veh												
LnGrp Delay(d),s/veh	11.0	13.8	12.5	11.3	23.8	21.8	37.0	38.1	42.2	37.2	38.4	40.0
LnGrp LOS	B	B	B	B	C	C	D	D	D	D	D	D
Approach Vol, veh/h		533			322			134				65
Approach Delay, s/veh		13.3			20.6			40.3				38.8
Approach LOS		B			C			D				D
Timer - Assigned Phs	1	2	3	4	5	6	7	8				
Phs Duration (G+Y+Rc), s	10.0	67.7	8.7	27.6	9.6	68.1	9.3	27.0				
Change Period (Y+Rc), s	6.0	6.0	6.5	6.5	6.0	6.0	6.5	6.5				
Max Green Setting (Gmax), s	8.0	50.0	10.5	20.5	8.0	50.0	10.5	20.5				
Max Q Clear Time (g_c+I1), s	4.3	8.9	3.3	7.0	4.0	7.9	3.9	4.0				
Green Ext Time (p_c), s	0.0	3.2	0.0	0.2	0.0	1.6	0.0	0.1				
Intersection Summary												
HCM 6th Ctrl Delay			20.5									
HCM 6th LOS			C									

Timings
3: Chapel Ridge Dr & Old Ranch Rd

Lane Group	EBL	EBT	EBR	WBL	WBT	WBR	NBL	NBT	NBR	SBL	SBT	SBR
Lane Configurations												
Traffic Volume (vph)	23	397	54	113	687	12	68	7	160	48	10	72
Future Volume (vph)	23	397	54	113	687	12	68	7	160	48	10	72
Turn Type	pm+pt	NA	Perm	pm+pt	NA	Perm	pm+pt	NA	Perm	pm+pt	NA	Perm
Protected Phases	5	2		1	6		7	4		3	8	
Permitted Phases	2		2	6		6	4		4	8		8
Detector Phase	5	2	2	1	6	6	7	4	4	3	8	8
Switch Phase												
Minimum Initial (s)	4.0	6.0	6.0	4.0	6.0	6.0	4.0	4.0	4.0	4.0	4.0	4.0
Minimum Split (s)	10.0	24.0	24.0	10.0	24.0	24.0	10.5	24.5	24.5	10.5	24.5	24.5
Total Split (s)	14.0	56.0	56.0	14.0	56.0	56.0	17.0	27.0	27.0	17.0	27.0	27.0
Total Split (%)	12.3%	49.1%	49.1%	12.3%	49.1%	49.1%	14.9%	23.7%	23.7%	14.9%	23.7%	23.7%
Yellow Time (s)	4.0	4.0	4.0	4.0	4.0	4.0	4.5	4.5	4.5	4.5	4.5	4.5
All-Red Time (s)	2.0	2.0	2.0	2.0	2.0	2.0	2.0	2.0	2.0	2.0	2.0	2.0
Lost Time Adjust (s)	0.0	0.0	0.0	0.0	0.0	0.0	0.0	0.0	0.0	0.0	0.0	0.0
Total Lost Time (s)	6.0	6.0	6.0	6.0	6.0	6.0	6.5	6.5	6.5	6.5	6.5	6.5
Lead/Lag	Lead	Lag	Lag	Lead	Lag	Lag	Lead	Lag	Lag	Lead	Lag	Lag
Lead-Lag Optimize?	Yes	Yes	Yes	Yes	Yes	Yes	Yes	Yes	Yes	Yes	Yes	Yes
Recall Mode	None	C-Max	C-Max	None	C-Max	C-Max	None	Max	Max	None	Max	Max
Act Effct Green (s)	56.5	50.2	50.2	61.1	56.3	56.3	33.0	25.3	25.3	31.6	24.6	24.6
Actuated g/C Ratio	0.50	0.44	0.44	0.54	0.49	0.49	0.29	0.22	0.22	0.28	0.22	0.22
v/c Ratio	0.09	0.32	0.09	0.31	0.49	0.02	0.20	0.01	0.40	0.14	0.02	0.20
Control Delay	12.1	21.5	0.2	25.0	34.9	0.0	28.6	38.0	8.1	27.9	38.5	1.8
Queue Delay	0.0	0.0	0.0	0.0	0.0	0.0	0.0	0.0	0.0	0.0	0.0	0.0
Total Delay	12.1	21.5	0.2	25.0	34.9	0.0	28.6	38.0	8.1	27.9	38.5	1.8
LOS	B	C	A	C	C	A	C	D	A	C	D	A
Approach Delay		18.6			33.0			15.0			14.4	
Approach LOS		B			C			B			B	

Intersection Summary

Cycle Length: 114
 Actuated Cycle Length: 114
 Offset: 33 (29%), Referenced to phase 2:EBTL and 6:WBTL, Start of Green
 Natural Cycle: 70
 Control Type: Actuated-Coordinated
 Maximum v/c Ratio: 0.49
 Intersection Signal Delay: 24.8
 Intersection LOS: C
 Intersection Capacity Utilization 48.2%
 ICU Level of Service A
 Analysis Period (min) 15

Splits and Phases: 3: Chapel Ridge Dr & Old Ranch Rd

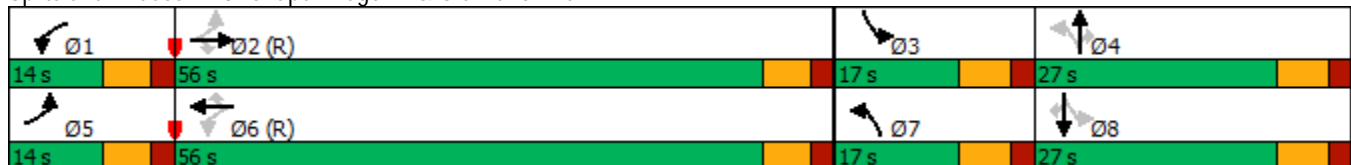

HCM 6th Signalized Intersection Summary
3: Chapel Ridge Dr & Old Ranch Rd

2025 Background AM

09/06/2023

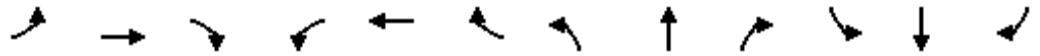

Movement	EBL	EBT	EBR	WBL	WBT	WBR	NBL	NBT	NBR	SBL	SBT	SBR
Lane Configurations	↘	↑↑	↗	↘	↑↑	↗	↘	↑↑	↗	↘	↑↑	↗
Traffic Volume (veh/h)	23	397	54	113	687	12	68	7	160	48	10	72
Future Volume (veh/h)	23	397	54	113	687	12	68	7	160	48	10	72
Initial Q (Qb), veh	0	0	0	0	0	0	0	0	0	0	0	0
Ped-Bike Adj(A_pbT)	1.00		1.00	1.00		1.00	1.00		1.00	1.00		1.00
Parking Bus, Adj	1.00	1.00	1.00	1.00	1.00	1.00	1.00	1.00	1.00	1.00	1.00	1.00
Work Zone On Approach		No			No			No			No	
Adj Sat Flow, veh/h/ln	1870	1870	1870	1870	1870	1870	1870	1870	1870	1870	1870	1870
Adj Flow Rate, veh/h	29	496	68	141	859	15	85	9	200	60	12	90
Peak Hour Factor	0.80	0.80	0.80	0.80	0.80	0.80	0.80	0.80	0.80	0.80	0.80	0.80
Percent Heavy Veh, %	2	2	2	2	2	2	2	2	2	2	2	2
Cap, veh/h	297	1751	781	509	1873	836	386	690	308	342	639	285
Arrive On Green	0.02	0.49	0.49	0.02	0.17	0.17	0.05	0.19	0.19	0.04	0.18	0.18
Sat Flow, veh/h	1781	3554	1585	1781	3554	1585	1781	3554	1585	1781	3554	1585
Grp Volume(v), veh/h	29	496	68	141	859	15	85	9	200	60	12	90
Grp Sat Flow(s),veh/h/ln	1781	1777	1585	1781	1777	1585	1781	1777	1585	1781	1777	1585
Q Serve(g_s), s	0.9	9.4	2.6	4.4	24.7	0.9	4.4	0.2	13.3	3.1	0.3	5.6
Cycle Q Clear(g_c), s	0.9	9.4	2.6	4.4	24.7	0.9	4.4	0.2	13.3	3.1	0.3	5.6
Prop In Lane	1.00		1.00	1.00		1.00	1.00		1.00	1.00		1.00
Lane Grp Cap(c), veh/h	297	1751	781	509	1873	836	386	690	308	342	639	285
V/C Ratio(X)	0.10	0.28	0.09	0.28	0.46	0.02	0.22	0.01	0.65	0.18	0.02	0.32
Avail Cap(c_a), veh/h	385	1751	781	536	1873	836	456	690	308	438	639	285
HCM Platoon Ratio	1.00	1.00	1.00	0.33	0.33	0.33	1.00	1.00	1.00	1.00	1.00	1.00
Upstream Filter(I)	1.00	1.00	1.00	0.93	0.93	0.93	1.00	1.00	1.00	1.00	1.00	1.00
Uniform Delay (d), s/veh	15.7	17.1	15.3	13.6	32.5	22.6	35.3	37.1	42.4	36.1	38.5	40.7
Incr Delay (d2), s/veh	0.1	0.4	0.2	0.3	0.8	0.0	0.3	0.0	10.2	0.2	0.1	2.9
Initial Q Delay(d3),s/veh	0.0	0.0	0.0	0.0	0.0	0.0	0.0	0.0	0.0	0.0	0.0	0.0
%ile BackOfQ(50%),veh/ln	0.4	3.9	1.0	1.9	12.0	0.3	1.9	0.1	6.0	1.4	0.1	2.4
Unsig. Movement Delay, s/veh												
LnGrp Delay(d),s/veh	15.8	17.5	15.5	13.9	33.2	22.7	35.5	37.1	52.6	36.3	38.5	43.5
LnGrp LOS	B	B	B	B	C	C	D	D	D	D	D	D
Approach Vol, veh/h		593			1015			294			162	
Approach Delay, s/veh		17.2			30.4			47.2			40.5	
Approach LOS		B			C			D			D	
Timer - Assigned Phs	1	2	3	4	5	6	7	8				
Phs Duration (G+Y+Rc), s	12.3	62.2	10.9	28.6	8.4	66.1	12.5	27.0				
Change Period (Y+Rc), s	6.0	6.0	6.5	6.5	6.0	6.0	6.5	6.5				
Max Green Setting (Gmax), s	8.0	50.0	10.5	20.5	8.0	50.0	10.5	20.5				
Max Q Clear Time (g_c+I1), s	6.4	11.4	5.1	15.3	2.9	26.7	6.4	7.6				
Green Ext Time (p_c), s	0.1	4.0	0.0	0.3	0.0	6.5	0.1	0.2				
Intersection Summary												
HCM 6th Ctrl Delay				29.8								
HCM 6th LOS				C								

Timings
3: Chapel Ridge Dr & Old Ranch Rd

Lane Group	EBL	EBT	EBR	WBL	WBT	WBR	NBL	NBT	NBR	SBL	SBT	SBR
Lane Configurations												
Traffic Volume (vph)	70	421	50	82	226	20	38	16	82	25	6	34
Future Volume (vph)	70	421	50	82	226	20	38	16	82	25	6	34
Turn Type	pm+pt	NA	Perm	pm+pt	NA	Perm	pm+pt	NA	Perm	pm+pt	NA	Perm
Protected Phases	5	2		1	6		7	4		3	8	
Permitted Phases	2		2	6		6	4		4	8		8
Detector Phase	5	2	2	1	6	6	7	4	4	3	8	8
Switch Phase												
Minimum Initial (s)	4.0	6.0	6.0	4.0	6.0	6.0	4.0	4.0	4.0	4.0	4.0	4.0
Minimum Split (s)	10.0	24.0	24.0	10.0	24.0	24.0	10.5	24.5	24.5	10.5	24.5	24.5
Total Split (s)	14.0	56.0	56.0	14.0	56.0	56.0	17.0	27.0	27.0	17.0	27.0	27.0
Total Split (%)	12.3%	49.1%	49.1%	12.3%	49.1%	49.1%	14.9%	23.7%	23.7%	14.9%	23.7%	23.7%
Yellow Time (s)	4.0	4.0	4.0	4.0	4.0	4.0	4.5	4.5	4.5	4.5	4.5	4.5
All-Red Time (s)	2.0	2.0	2.0	2.0	2.0	2.0	2.0	2.0	2.0	2.0	2.0	2.0
Lost Time Adjust (s)	0.0	0.0	0.0	0.0	0.0	0.0	0.0	0.0	0.0	0.0	0.0	0.0
Total Lost Time (s)	6.0	6.0	6.0	6.0	6.0	6.0	6.5	6.5	6.5	6.5	6.5	6.5
Lead/Lag	Lead	Lag	Lag	Lead	Lag	Lag	Lead	Lag	Lag	Lead	Lag	Lag
Lead-Lag Optimize?	Yes	Yes	Yes	Yes	Yes	Yes	Yes	Yes	Yes	Yes	Yes	Yes
Recall Mode	None	C-Max	C-Max	None	C-Max	C-Max	None	Max	Max	None	Max	Max
Act Effct Green (s)	59.1	53.0	53.0	59.3	53.1	53.1	34.1	29.2	29.2	33.1	28.8	28.8
Actuated g/C Ratio	0.52	0.46	0.46	0.52	0.47	0.47	0.30	0.26	0.26	0.29	0.25	0.25
v/c Ratio	0.11	0.26	0.06	0.16	0.14	0.02	0.09	0.02	0.16	0.06	0.01	0.07
Control Delay	12.1	19.9	0.1	11.6	15.9	0.1	27.1	35.9	0.8	26.8	37.0	0.3
Queue Delay	0.0	0.0	0.0	0.0	0.0	0.0	0.0	0.0	0.0	0.0	0.0	0.0
Total Delay	12.1	19.9	0.1	11.6	15.9	0.1	27.1	35.9	0.8	26.8	37.0	0.3
LOS	B	B	A	B	B	A	C	D	A	C	D	A
Approach Delay		17.0			13.9			12.2			13.9	
Approach LOS		B			B			B			B	

Intersection Summary

Cycle Length: 114
 Actuated Cycle Length: 114
 Offset: 33 (29%), Referenced to phase 2:EBTL and 6:WBTL, Start of Green
 Natural Cycle: 70
 Control Type: Actuated-Coordinated
 Maximum v/c Ratio: 0.26
 Intersection Signal Delay: 15.3
 Intersection Capacity Utilization 40.4%
 Analysis Period (min) 15
 Intersection LOS: B
 ICU Level of Service A

Splits and Phases: 3: Chapel Ridge Dr & Old Ranch Rd



HCM 6th Signalized Intersection Summary
 3: Chapel Ridge Dr & Old Ranch Rd

2025 Background PM

09/06/2023

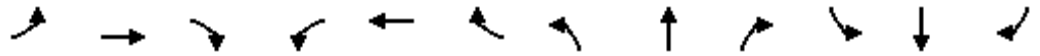

Movement	EBL	EBT	EBR	WBL	WBT	WBR	NBL	NBT	NBR	SBL	SBT	SBR
Lane Configurations												
Traffic Volume (veh/h)	70	421	50	82	226	20	38	16	82	25	6	34
Future Volume (veh/h)	70	421	50	82	226	20	38	16	82	25	6	34
Initial Q (Qb), veh	0	0	0	0	0	0	0	0	0	0	0	0
Ped-Bike Adj(A_pbT)	1.00		1.00	1.00		1.00	1.00		1.00	1.00		1.00
Parking Bus, Adj	1.00	1.00	1.00	1.00	1.00	1.00	1.00	1.00	1.00	1.00	1.00	1.00
Work Zone On Approach		No			No			No			No	
Adj Sat Flow, veh/h/ln	1870	1870	1870	1870	1870	1870	1870	1870	1870	1870	1870	1870
Adj Flow Rate, veh/h	71	425	51	83	228	20	38	16	83	25	6	34
Peak Hour Factor	0.99	0.99	0.99	0.99	0.99	0.99	0.99	0.99	0.99	0.99	0.99	0.99
Percent Heavy Veh, %	2	2	2	2	2	2	2	2	2	2	2	2
Cap, veh/h	675	1921	857	566	1935	863	351	658	294	330	639	285
Arrive On Green	0.03	0.54	0.54	0.01	0.18	0.18	0.02	0.19	0.19	0.02	0.18	0.18
Sat Flow, veh/h	1781	3554	1585	1781	3554	1585	1781	3554	1585	1781	3554	1585
Grp Volume(v), veh/h	71	425	51	83	228	20	38	16	83	25	6	34
Grp Sat Flow(s),veh/h/ln	1781	1777	1585	1781	1777	1585	1781	1777	1585	1781	1777	1585
Q Serve(g_s), s	2.0	7.1	1.7	2.3	6.1	1.2	2.0	0.4	5.1	1.3	0.2	2.0
Cycle Q Clear(g_c), s	2.0	7.1	1.7	2.3	6.1	1.2	2.0	0.4	5.1	1.3	0.2	2.0
Prop In Lane	1.00		1.00	1.00		1.00	1.00		1.00	1.00		1.00
Lane Grp Cap(c), veh/h	675	1921	857	566	1935	863	351	658	294	330	639	285
V/C Ratio(X)	0.11	0.22	0.06	0.15	0.12	0.02	0.11	0.02	0.28	0.08	0.01	0.12
Avail Cap(c_a), veh/h	743	1921	857	627	1935	863	471	658	294	460	639	285
HCM Platoon Ratio	1.00	1.00	1.00	0.33	0.33	0.33	1.00	1.00	1.00	1.00	1.00	1.00
Upstream Filter(l)	1.00	1.00	1.00	1.00	1.00	1.00	1.00	1.00	1.00	1.00	1.00	1.00
Uniform Delay (d), s/veh	11.0	13.7	12.4	11.2	23.8	21.8	36.9	38.0	39.9	37.1	38.4	39.2
Incr Delay (d2), s/veh	0.1	0.3	0.1	0.1	0.1	0.0	0.1	0.1	2.4	0.1	0.0	0.9
Initial Q Delay(d3),s/veh	0.0	0.0	0.0	0.0	0.0	0.0	0.0	0.0	0.0	0.0	0.0	0.0
%ile BackOfQ(50%),veh/ln	0.8	2.9	0.6	1.0	2.7	0.4	0.9	0.2	2.2	0.6	0.1	0.9
Unsig. Movement Delay, s/veh												
LnGrp Delay(d),s/veh	11.1	13.9	12.6	11.4	23.9	21.8	37.0	38.1	42.3	37.2	38.4	40.0
LnGrp LOS	B	B	B	B	C	C	D	D	D	D	D	D
Approach Vol, veh/h		547			331			137				65
Approach Delay, s/veh		13.4			20.7			40.4				38.8
Approach LOS		B			C			D				D
Timer - Assigned Phs	1	2	3	4	5	6	7	8				
Phs Duration (G+Y+Rc), s	10.1	67.6	8.7	27.6	9.6	68.1	9.3	27.0				
Change Period (Y+Rc), s	6.0	6.0	6.5	6.5	6.0	6.0	6.5	6.5				
Max Green Setting (Gmax), s	8.0	50.0	10.5	20.5	8.0	50.0	10.5	20.5				
Max Q Clear Time (g_c+I1), s	4.3	9.1	3.3	7.1	4.0	8.1	4.0	4.0				
Green Ext Time (p_c), s	0.0	3.3	0.0	0.2	0.0	1.6	0.0	0.1				
Intersection Summary												
HCM 6th Ctrl Delay				20.6								
HCM 6th LOS				C								

Timings
3: Chapel Ridge Dr & Old Ranch Rd

2025 Total AM
09/06/2023

Lane Group	EBL	EBT	EBR	WBL	WBT	WBR	NBL	NBT	NBR	SBL	SBT	SBR
Lane Configurations												
Traffic Volume (vph)	57	397	54	113	687	37	68	10	160	118	19	169
Future Volume (vph)	57	397	54	113	687	37	68	10	160	118	19	169
Turn Type	pm+pt	NA	Perm	pm+pt	NA	Perm	pm+pt	NA	Perm	pm+pt	NA	Perm
Protected Phases	5	2		1	6		7	4		3	8	
Permitted Phases	2		2	6		6	4		4	8		8
Detector Phase	5	2	2	1	6	6	7	4	4	3	8	8
Switch Phase												
Minimum Initial (s)	4.0	6.0	6.0	4.0	6.0	6.0	4.0	4.0	4.0	4.0	4.0	4.0
Minimum Split (s)	10.0	24.0	24.0	10.0	24.0	24.0	10.5	24.5	24.5	10.5	24.5	24.5
Total Split (s)	14.0	56.0	56.0	14.0	56.0	56.0	17.0	27.0	27.0	17.0	27.0	27.0
Total Split (%)	12.3%	49.1%	49.1%	12.3%	49.1%	49.1%	14.9%	23.7%	23.7%	14.9%	23.7%	23.7%
Yellow Time (s)	4.0	4.0	4.0	4.0	4.0	4.0	4.5	4.5	4.5	4.5	4.5	4.5
All-Red Time (s)	2.0	2.0	2.0	2.0	2.0	2.0	2.0	2.0	2.0	2.0	2.0	2.0
Lost Time Adjust (s)	0.0	0.0	0.0	0.0	0.0	0.0	0.0	0.0	0.0	0.0	0.0	0.0
Total Lost Time (s)	6.0	6.0	6.0	6.0	6.0	6.0	6.5	6.5	6.5	6.5	6.5	6.5
Lead/Lag	Lead	Lag	Lag	Lead	Lag	Lag	Lead	Lag	Lag	Lead	Lag	Lag
Lead-Lag Optimize?	Yes	Yes	Yes	Yes	Yes	Yes	Yes	Yes	Yes	Yes	Yes	Yes
Recall Mode	None	C-Max	C-Max	None	C-Max	C-Max	None	Max	Max	None	Max	Max
Act Effct Green (s)	57.4	50.2	50.2	59.5	53.1	53.1	29.9	21.0	21.0	33.0	24.6	24.6
Actuated g/C Ratio	0.50	0.44	0.44	0.52	0.47	0.47	0.26	0.18	0.18	0.29	0.22	0.22
v/c Ratio	0.23	0.32	0.09	0.30	0.52	0.06	0.22	0.02	0.44	0.36	0.03	0.42
Control Delay	13.6	21.5	0.2	24.9	37.3	2.0	28.9	38.7	9.0	31.3	38.5	8.2
Queue Delay	0.0	0.0	0.0	0.0	0.0	0.0	0.0	0.0	0.0	0.0	0.0	0.0
Total Delay	13.6	21.5	0.2	24.9	37.3	2.0	28.9	38.7	9.0	31.3	38.5	8.2
LOS	B	C	A	C	D	A	C	D	A	C	D	A
Approach Delay		18.4			34.1			15.9			19.0	
Approach LOS		B			C			B			B	

Intersection Summary

Cycle Length: 114
 Actuated Cycle Length: 114
 Offset: 33 (29%), Referenced to phase 2:EBTL and 6:WBTL, Start of Green
 Natural Cycle: 70
 Control Type: Actuated-Coordinated
 Maximum v/c Ratio: 0.52
 Intersection Signal Delay: 25.1
 Intersection LOS: C
 Intersection Capacity Utilization 50.9%
 ICU Level of Service A
 Analysis Period (min) 15

Splits and Phases: 3: Chapel Ridge Dr & Old Ranch Rd

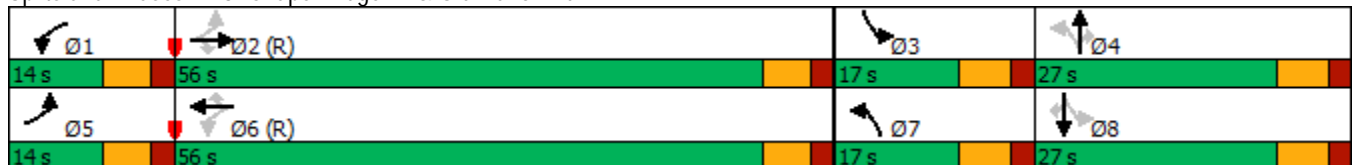

HCM 6th Signalized Intersection Summary
 3: Chapel Ridge Dr & Old Ranch Rd

2025 Total AM
 09/06/2023



Movement	EBL	EBT	EBR	WBL	WBT	WBR	NBL	NBT	NBR	SBL	SBT	SBR
Lane Configurations												
Traffic Volume (veh/h)	57	397	54	113	687	37	68	10	160	118	19	169
Future Volume (veh/h)	57	397	54	113	687	37	68	10	160	118	19	169
Initial Q (Qb), veh	0	0	0	0	0	0	0	0	0	0	0	0
Ped-Bike Adj(A_pbT)	1.00		1.00	1.00		1.00	1.00		1.00	1.00		1.00
Parking Bus, Adj	1.00	1.00	1.00	1.00	1.00	1.00	1.00	1.00	1.00	1.00	1.00	1.00
Work Zone On Approach		No			No			No			No	
Adj Sat Flow, veh/h/ln	1870	1870	1870	1870	1870	1870	1870	1870	1870	1870	1870	1870
Adj Flow Rate, veh/h	71	496	68	141	859	46	85	12	200	148	24	211
Peak Hour Factor	0.80	0.80	0.80	0.80	0.80	0.80	0.80	0.80	0.80	0.80	0.80	0.80
Percent Heavy Veh, %	2	2	2	2	2	2	2	2	2	2	2	2
Cap, veh/h	286	1631	727	481	1714	765	363	639	285	419	750	334
Arrive On Green	0.03	0.46	0.46	0.02	0.16	0.16	0.05	0.18	0.18	0.08	0.21	0.21
Sat Flow, veh/h	1781	3554	1585	1781	3554	1585	1781	3554	1585	1781	3554	1585
Grp Volume(v), veh/h	71	496	68	141	859	46	85	12	200	148	24	211
Grp Sat Flow(s),veh/h/ln	1781	1777	1585	1781	1777	1585	1781	1777	1585	1781	1777	1585
Q Serve(g_s), s	2.4	10.0	2.8	4.7	25.2	2.8	4.4	0.3	13.5	7.6	0.6	13.8
Cycle Q Clear(g_c), s	2.4	10.0	2.8	4.7	25.2	2.8	4.4	0.3	13.5	7.6	0.6	13.8
Prop In Lane	1.00		1.00	1.00		1.00	1.00		1.00	1.00		1.00
Lane Grp Cap(c), veh/h	286	1631	727	481	1714	765	363	639	285	419	750	334
V/C Ratio(X)	0.25	0.30	0.09	0.29	0.50	0.06	0.23	0.02	0.70	0.35	0.03	0.63
Avail Cap(c_a), veh/h	349	1631	727	502	1714	765	433	639	285	434	750	334
HCM Platoon Ratio	1.00	1.00	1.00	0.33	0.33	0.33	1.00	1.00	1.00	1.00	1.00	1.00
Upstream Filter(l)	1.00	1.00	1.00	0.93	0.93	0.93	1.00	1.00	1.00	1.00	1.00	1.00
Uniform Delay (d), s/veh	17.7	19.4	17.4	15.6	35.4	26.0	35.3	38.5	43.9	33.7	35.7	40.9
Incr Delay (d2), s/veh	0.4	0.5	0.3	0.3	1.0	0.1	0.3	0.1	13.5	0.5	0.1	8.7
Initial Q Delay(d3),s/veh	0.0	0.0	0.0	0.0	0.0	0.0	0.0	0.0	0.0	0.0	0.0	0.0
%ile BackOfQ(50%),veh/ln	1.0	4.2	1.1	2.0	12.2	1.1	1.9	0.1	6.3	3.3	0.3	6.2
Unsig. Movement Delay, s/veh												
LnGrp Delay(d),s/veh	18.2	19.9	17.7	15.9	36.4	26.1	35.6	38.5	57.4	34.2	35.8	49.7
LnGrp LOS	B	B	B	B	D	C	D	D	E	C	D	D
Approach Vol, veh/h		635			1046			297			383	
Approach Delay, s/veh		19.4			33.2			50.4			42.8	
Approach LOS		B			C			D			D	
Timer - Assigned Phs	1	2	3	4	5	6	7	8				
Phs Duration (G+Y+Rc), s	12.6	58.3	16.1	27.0	10.0	61.0	12.5	30.5				
Change Period (Y+Rc), s	6.0	6.0	6.5	6.5	6.0	6.0	6.5	6.5				
Max Green Setting (Gmax), s	8.0	50.0	10.5	20.5	8.0	50.0	10.5	20.5				
Max Q Clear Time (g_c+I1), s	6.7	12.0	9.6	15.5	4.4	27.2	6.4	15.8				
Green Ext Time (p_c), s	0.0	4.0	0.0	0.3	0.0	6.6	0.1	0.3				
Intersection Summary												
HCM 6th Ctrl Delay					33.2							
HCM 6th LOS					C							

HCM 6th Signalized Intersection Summary
 3: Chapel Ridge Dr & Old Ranch Rd

2025 Total PM
 09/06/2023



Movement	EBL	EBT	EBR	WBL	WBT	WBR	NBL	NBT	NBR	SBL	SBT	SBR
Lane Configurations												
Traffic Volume (veh/h)	185	421	50	82	226	104	38	26	82	74	12	101
Future Volume (veh/h)	185	421	50	82	226	104	38	26	82	74	12	101
Initial Q (Qb), veh	0	0	0	0	0	0	0	0	0	0	0	0
Ped-Bike Adj(A_pbT)	1.00		1.00	1.00		1.00	1.00		1.00	1.00		1.00
Parking Bus, Adj	1.00	1.00	1.00	1.00	1.00	1.00	1.00	1.00	1.00	1.00	1.00	1.00
Work Zone On Approach		No			No			No			No	
Adj Sat Flow, veh/h/ln	1870	1870	1870	1870	1870	1870	1870	1870	1870	1870	1870	1870
Adj Flow Rate, veh/h	187	425	51	83	228	105	38	26	83	75	12	102
Peak Hour Factor	0.99	0.99	0.99	0.99	0.99	0.99	0.99	0.99	0.99	0.99	0.99	0.99
Percent Heavy Veh, %	2	2	2	2	2	2	2	2	2	2	2	2
Cap, veh/h	637	1832	817	544	1720	767	337	639	285	370	719	321
Arrive On Green	0.07	0.52	0.52	0.01	0.16	0.16	0.02	0.18	0.18	0.05	0.20	0.20
Sat Flow, veh/h	1781	3554	1585	1781	3554	1585	1781	3554	1585	1781	3554	1585
Grp Volume(v), veh/h	187	425	51	83	228	105	38	26	83	75	12	102
Grp Sat Flow(s),veh/h/ln	1781	1777	1585	1781	1777	1585	1781	1777	1585	1781	1777	1585
Q Serve(g_s), s	6.0	7.5	1.8	2.6	6.3	6.5	2.0	0.7	5.2	3.9	0.3	6.3
Cycle Q Clear(g_c), s	6.0	7.5	1.8	2.6	6.3	6.5	2.0	0.7	5.2	3.9	0.3	6.3
Prop In Lane	1.00		1.00	1.00		1.00	1.00		1.00	1.00		1.00
Lane Grp Cap(c), veh/h	637	1832	817	544	1720	767	337	639	285	370	719	321
V/C Ratio(X)	0.29	0.23	0.06	0.15	0.13	0.14	0.11	0.04	0.29	0.20	0.02	0.32
Avail Cap(c_a), veh/h	637	1832	817	601	1720	767	457	639	285	450	719	321
HCM Platoon Ratio	1.00	1.00	1.00	0.33	0.33	0.33	1.00	1.00	1.00	1.00	1.00	1.00
Upstream Filter(l)	1.00	1.00	1.00	1.00	1.00	1.00	1.00	1.00	1.00	1.00	1.00	1.00
Uniform Delay (d), s/veh	12.9	15.2	13.8	14.1	27.4	27.4	36.9	38.6	40.5	35.6	36.4	38.8
Incr Delay (d2), s/veh	0.3	0.3	0.1	0.1	0.2	0.4	0.1	0.1	2.6	0.3	0.0	2.6
Initial Q Delay(d3),s/veh	0.0	0.0	0.0	0.0	0.0	0.0	0.0	0.0	0.0	0.0	0.0	0.0
%ile BackOfQ(50%),veh/ln	2.4	3.1	0.7	1.1	2.8	2.7	0.9	0.3	2.2	1.7	0.1	2.7
Unsig. Movement Delay, s/veh												
LnGrp Delay(d),s/veh	13.1	15.5	14.0	14.2	27.5	27.8	37.0	38.7	43.0	35.8	36.4	41.3
LnGrp LOS	B	B	B	B	C	C	D	D	D	D	D	D
Approach Vol, veh/h		663			416			147				189
Approach Delay, s/veh		14.7			24.9			40.7				38.8
Approach LOS		B			C			D				D
Timer - Assigned Phs	1	2	3	4	5	6	7	8				
Phs Duration (G+Y+Rc), s	10.4	64.8	11.9	27.0	13.9	61.2	9.3	29.6				
Change Period (Y+Rc), s	6.0	6.0	6.5	6.5	6.0	6.0	6.5	6.5				
Max Green Setting (Gmax), s	8.0	50.0	10.5	20.5	8.0	50.0	10.5	20.5				
Max Q Clear Time (g_c+I1), s	4.6	9.5	5.9	7.2	8.0	8.5	4.0	8.3				
Green Ext Time (p_c), s	0.0	3.3	0.1	0.3	0.0	1.9	0.0	0.2				
Intersection Summary												
HCM 6th Ctrl Delay				23.6								
HCM 6th LOS				C								

Timings

3: Chapel Ridge Dr & Old Ranch Rd

2045 Background AM
09/06/2023

Lane Group	EBL	EBT	EBR	WBL	WBT	WBR	NBL	NBT	NBR	SBL	SBT	SBR
Lane Configurations												
Traffic Volume (vph)	23	534	72	153	926	12	92	7	215	48	10	72
Future Volume (vph)	23	534	72	153	926	12	92	7	215	48	10	72
Turn Type	pm+pt	NA	Perm	pm+pt	NA	Perm	pm+pt	NA	Perm	pm+pt	NA	Perm
Protected Phases	5	2		1	6		7	4		3	8	
Permitted Phases	2		2	6		6	4		4	8		8
Detector Phase	5	2	2	1	6	6	7	4	4	3	8	8
Switch Phase												
Minimum Initial (s)	4.0	6.0	6.0	4.0	6.0	6.0	4.0	4.0	4.0	4.0	4.0	4.0
Minimum Split (s)	10.0	24.0	24.0	10.0	24.0	24.0	10.5	24.5	24.5	10.5	24.5	24.5
Total Split (s)	14.0	56.0	56.0	14.0	56.0	56.0	17.0	27.0	27.0	17.0	27.0	27.0
Total Split (%)	12.3%	49.1%	49.1%	12.3%	49.1%	49.1%	14.9%	23.7%	23.7%	14.9%	23.7%	23.7%
Yellow Time (s)	4.0	4.0	4.0	4.0	4.0	4.0	4.5	4.5	4.5	4.5	4.5	4.5
All-Red Time (s)	2.0	2.0	2.0	2.0	2.0	2.0	2.0	2.0	2.0	2.0	2.0	2.0
Lost Time Adjust (s)	0.0	0.0	0.0	0.0	0.0	0.0	0.0	0.0	0.0	0.0	0.0	0.0
Total Lost Time (s)	6.0	6.0	6.0	6.0	6.0	6.0	6.5	6.5	6.5	6.5	6.5	6.5
Lead/Lag	Lead	Lag	Lag	Lead	Lag	Lag	Lead	Lag	Lag	Lead	Lag	Lag
Lead-Lag Optimize?	Yes	Yes	Yes	Yes	Yes	Yes	Yes	Yes	Yes	Yes	Yes	Yes
Recall Mode	None	C-Max	C-Max	None	C-Max	C-Max	None	Max	Max	None	Max	Max
Act Effct Green (s)	56.4	50.0	50.0	61.1	56.3	56.3	33.5	25.3	25.3	29.5	21.4	21.4
Actuated g/C Ratio	0.49	0.44	0.44	0.54	0.49	0.49	0.29	0.22	0.22	0.26	0.19	0.19
v/c Ratio	0.14	0.43	0.12	0.50	0.66	0.02	0.28	0.01	0.48	0.15	0.02	0.22
Control Delay	12.9	23.2	0.5	31.9	41.4	0.0	29.7	38.0	8.0	28.1	38.7	2.0
Queue Delay	0.0	0.0	0.0	0.0	0.0	0.0	0.0	0.0	0.0	0.0	0.0	0.0
Total Delay	12.9	23.2	0.5	31.9	41.4	0.0	29.7	38.0	8.0	28.1	38.7	2.0
LOS	B	C	A	C	D	A	C	D	A	C	D	A
Approach Delay		20.3			39.6			15.0			14.5	
Approach LOS		C			D			B			B	

Intersection Summary

Cycle Length: 114	
Actuated Cycle Length: 114	
Offset: 33 (29%), Referenced to phase 2:EBTL and 6:WBTL, Start of Green	
Natural Cycle: 75	
Control Type: Actuated-Coordinated	
Maximum v/c Ratio: 0.66	
Intersection Signal Delay: 28.9	Intersection LOS: C
Intersection Capacity Utilization 56.1%	ICU Level of Service B
Analysis Period (min) 15	

Splits and Phases: 3: Chapel Ridge Dr & Old Ranch Rd

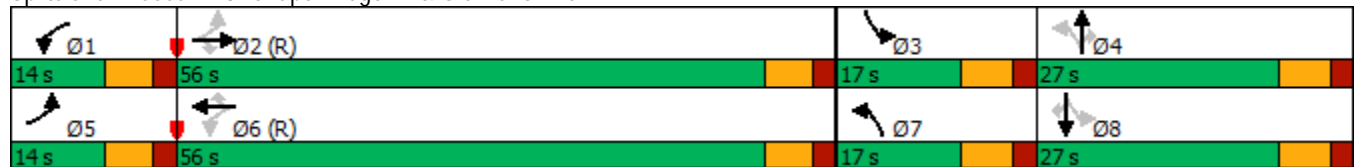

HCM 6th Signalized Intersection Summary
3: Chapel Ridge Dr & Old Ranch Rd

2045 Background AM

09/06/2023

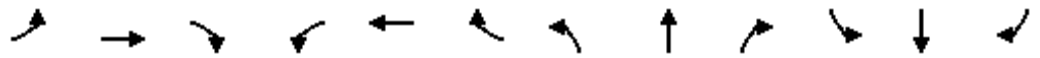

Movement	EBL	EBT	EBR	WBL	WBT	WBR	NBL	NBT	NBR	SBL	SBT	SBR
Lane Configurations	↘	↗↗	↘	↘	↗↗	↘	↘	↗↗	↘	↘	↗↗	↘
Traffic Volume (veh/h)	23	534	72	153	926	12	92	7	215	48	10	72
Future Volume (veh/h)	23	534	72	153	926	12	92	7	215	48	10	72
Initial Q (Qb), veh	0	0	0	0	0	0	0	0	0	0	0	0
Ped-Bike Adj(A_pbT)	1.00		1.00	1.00		1.00	1.00		1.00	1.00		1.00
Parking Bus, Adj	1.00	1.00	1.00	1.00	1.00	1.00	1.00	1.00	1.00	1.00	1.00	1.00
Work Zone On Approach		No			No			No			No	
Adj Sat Flow, veh/h/ln	1870	1870	1870	1870	1870	1870	1870	1870	1870	1870	1870	1870
Adj Flow Rate, veh/h	29	668	90	191	1158	15	115	9	269	60	12	90
Peak Hour Factor	0.80	0.80	0.80	0.80	0.80	0.80	0.80	0.80	0.80	0.80	0.80	0.80
Percent Heavy Veh, %	2	2	2	2	2	2	2	2	2	2	2	2
Cap, veh/h	200	1644	733	427	1818	811	413	745	332	330	639	285
Arrive On Green	0.02	0.46	0.46	0.02	0.17	0.17	0.07	0.21	0.21	0.04	0.18	0.18
Sat Flow, veh/h	1781	3554	1585	1781	3554	1585	1781	3554	1585	1781	3554	1585
Grp Volume(v), veh/h	29	668	90	191	1158	15	115	9	269	60	12	90
Grp Sat Flow(s),veh/h/ln	1781	1777	1585	1781	1777	1585	1781	1777	1585	1781	1777	1585
Q Serve(g_s), s	1.0	14.2	3.7	6.0	34.6	0.9	5.9	0.2	18.4	3.1	0.3	5.6
Cycle Q Clear(g_c), s	1.0	14.2	3.7	6.0	34.6	0.9	5.9	0.2	18.4	3.1	0.3	5.6
Prop In Lane	1.00		1.00	1.00		1.00	1.00		1.00	1.00		1.00
Lane Grp Cap(c), veh/h	200	1644	733	427	1818	811	413	745	332	330	639	285
V/C Ratio(X)	0.14	0.41	0.12	0.45	0.64	0.02	0.28	0.01	0.81	0.18	0.02	0.32
Avail Cap(c_a), veh/h	288	1644	733	427	1818	811	456	745	332	425	639	285
HCM Platoon Ratio	1.00	1.00	1.00	0.33	0.33	0.33	1.00	1.00	1.00	1.00	1.00	1.00
Upstream Filter(l)	1.00	1.00	1.00	0.85	0.85	0.85	1.00	1.00	1.00	1.00	1.00	1.00
Uniform Delay (d), s/veh	19.4	20.3	17.5	15.3	37.5	23.5	34.5	35.7	42.9	36.1	38.5	40.7
Incr Delay (d2), s/veh	0.3	0.7	0.3	0.6	1.5	0.0	0.4	0.0	18.9	0.3	0.1	2.9
Initial Q Delay(d3),s/veh	0.0	0.0	0.0	0.0	0.0	0.0	0.0	0.0	0.0	0.0	0.0	0.0
%ile BackOfQ(50%),veh/ln	0.4	6.0	1.4	2.7	16.8	0.3	2.6	0.1	8.9	1.4	0.1	2.4
Unsig. Movement Delay, s/veh												
LnGrp Delay(d),s/veh	19.7	21.0	17.8	16.0	39.0	23.5	34.8	35.7	61.8	36.3	38.5	43.5
LnGrp LOS	B	C	B	B	D	C	C	D	E	D	D	D
Approach Vol, veh/h		787			1364			393			162	
Approach Delay, s/veh		20.6			35.6			53.3			40.5	
Approach LOS		C			D			D			D	
Timer - Assigned Phs	1	2	3	4	5	6	7	8				
Phs Duration (G+Y+Rc), s	14.0	58.7	10.9	30.4	8.4	64.3	14.3	27.0				
Change Period (Y+Rc), s	6.0	6.0	6.5	6.5	6.0	6.0	6.5	6.5				
Max Green Setting (Gmax), s	8.0	50.0	10.5	20.5	8.0	50.0	10.5	20.5				
Max Q Clear Time (g_c+I1), s	8.0	16.2	5.1	20.4	3.0	36.6	7.9	7.6				
Green Ext Time (p_c), s	0.0	5.6	0.0	0.0	0.0	6.9	0.1	0.2				
Intersection Summary												
HCM 6th Ctrl Delay					34.1							
HCM 6th LOS					C							

Timings
3: Chapel Ridge Dr & Old Ranch Rd

Lane Group	EBL	EBT	EBR	WBL	WBT	WBR	NBL	NBT	NBR	SBL	SBT	SBR
Lane Configurations												
Traffic Volume (vph)	70	568	68	111	304	20	51	16	111	25	6	34
Future Volume (vph)	70	568	68	111	304	20	51	16	111	25	6	34
Turn Type	pm+pt	NA	Perm	pm+pt	NA	Perm	pm+pt	NA	Perm	pm+pt	NA	Perm
Protected Phases	5	2		1	6		7	4		3	8	
Permitted Phases	2		2	6		6	4		4	8		8
Detector Phase	5	2	2	1	6	6	7	4	4	3	8	8
Switch Phase												
Minimum Initial (s)	4.0	6.0	6.0	4.0	6.0	6.0	4.0	4.0	4.0	4.0	4.0	4.0
Minimum Split (s)	10.0	24.0	24.0	10.0	24.0	24.0	10.5	24.5	24.5	10.5	24.5	24.5
Total Split (s)	14.0	56.0	56.0	14.0	56.0	56.0	17.0	27.0	27.0	17.0	27.0	27.0
Total Split (%)	12.3%	49.1%	49.1%	12.3%	49.1%	49.1%	14.9%	23.7%	23.7%	14.9%	23.7%	23.7%
Yellow Time (s)	4.0	4.0	4.0	4.0	4.0	4.0	4.5	4.5	4.5	4.5	4.5	4.5
All-Red Time (s)	2.0	2.0	2.0	2.0	2.0	2.0	2.0	2.0	2.0	2.0	2.0	2.0
Lost Time Adjust (s)	0.0	0.0	0.0	0.0	0.0	0.0	0.0	0.0	0.0	0.0	0.0	0.0
Total Lost Time (s)	6.0	6.0	6.0	6.0	6.0	6.0	6.5	6.5	6.5	6.5	6.5	6.5
Lead/Lag	Lead	Lag	Lag	Lead	Lag	Lag	Lead	Lag	Lag	Lead	Lag	Lag
Lead-Lag Optimize?	Yes	Yes	Yes	Yes	Yes	Yes	Yes	Yes	Yes	Yes	Yes	Yes
Recall Mode	None	C-Max	C-Max	None	C-Max	C-Max	None	Max	Max	None	Max	Max
Act Effct Green (s)	57.5	50.3	50.3	59.5	53.1	53.1	34.6	29.2	29.2	31.2	25.6	25.6
Actuated g/C Ratio	0.50	0.44	0.44	0.52	0.47	0.47	0.30	0.26	0.26	0.27	0.22	0.22
v/c Ratio	0.12	0.37	0.09	0.27	0.19	0.02	0.12	0.02	0.22	0.06	0.01	0.07
Control Delay	12.2	22.1	0.2	18.1	18.4	0.1	27.5	35.9	3.6	26.9	37.7	0.3
Queue Delay	0.0	0.0	0.0	0.0	0.0	0.0	0.0	0.0	0.0	0.0	0.0	0.0
Total Delay	12.2	22.1	0.2	18.1	18.4	0.1	27.5	35.9	3.6	26.9	37.7	0.3
LOS	B	C	A	B	B	A	C	D	A	C	D	A
Approach Delay		19.0			17.5			13.4			14.0	
Approach LOS		B			B			B			B	

Intersection Summary

Cycle Length: 114
 Actuated Cycle Length: 114
 Offset: 33 (29%), Referenced to phase 2:EBTL and 6:WBTL, Start of Green
 Natural Cycle: 70
 Control Type: Actuated-Coordinated
 Maximum v/c Ratio: 0.37
 Intersection Signal Delay: 17.6
 Intersection LOS: B
 Intersection Capacity Utilization 46.8%
 ICU Level of Service A
 Analysis Period (min) 15

Splits and Phases: 3: Chapel Ridge Dr & Old Ranch Rd

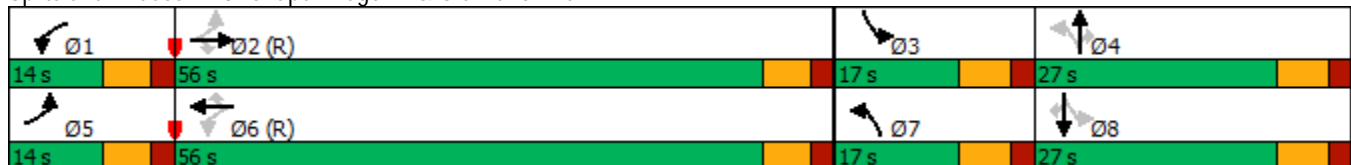

HCM 6th Signalized Intersection Summary
3: Chapel Ridge Dr & Old Ranch Rd

2045 Background PM

09/06/2023

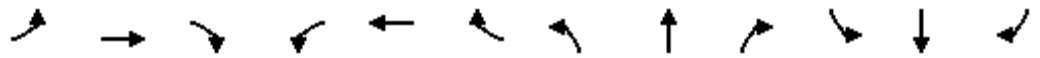

Movement	EBL	EBT	EBR	WBL	WBT	WBR	NBL	NBT	NBR	SBL	SBT	SBR
Lane Configurations	↘	↑↑	↗	↘	↑↑	↗	↘	↑↑	↗	↘	↑↑	↗
Traffic Volume (veh/h)	70	568	68	111	304	20	51	16	111	25	6	34
Future Volume (veh/h)	70	568	68	111	304	20	51	16	111	25	6	34
Initial Q (Qb), veh	0	0	0	0	0	0	0	0	0	0	0	0
Ped-Bike Adj(A_pbT)	1.00		1.00	1.00		1.00	1.00		1.00	1.00		1.00
Parking Bus, Adj	1.00	1.00	1.00	1.00	1.00	1.00	1.00	1.00	1.00	1.00	1.00	1.00
Work Zone On Approach		No			No			No			No	
Adj Sat Flow, veh/h/ln	1870	1870	1870	1870	1870	1870	1870	1870	1870	1870	1870	1870
Adj Flow Rate, veh/h	71	574	69	112	307	20	52	16	112	25	6	34
Peak Hour Factor	0.99	0.99	0.99	0.99	0.99	0.99	0.99	0.99	0.99	0.99	0.99	0.99
Percent Heavy Veh, %	2	2	2	2	2	2	2	2	2	2	2	2
Cap, veh/h	607	1855	827	482	1901	848	367	690	308	324	639	285
Arrive On Green	0.03	0.52	0.52	0.01	0.18	0.18	0.03	0.19	0.19	0.02	0.18	0.18
Sat Flow, veh/h	1781	3554	1585	1781	3554	1585	1781	3554	1585	1781	3554	1585
Grp Volume(v), veh/h	71	574	69	112	307	20	52	16	112	25	6	34
Grp Sat Flow(s),veh/h/ln	1781	1777	1585	1781	1777	1585	1781	1777	1585	1781	1777	1585
Q Serve(g_s), s	2.1	10.5	2.5	3.3	8.3	1.2	2.7	0.4	7.0	1.3	0.2	2.0
Cycle Q Clear(g_c), s	2.1	10.5	2.5	3.3	8.3	1.2	2.7	0.4	7.0	1.3	0.2	2.0
Prop In Lane	1.00		1.00	1.00		1.00	1.00		1.00	1.00		1.00
Lane Grp Cap(c), veh/h	607	1855	827	482	1901	848	367	690	308	324	639	285
V/C Ratio(X)	0.12	0.31	0.08	0.23	0.16	0.02	0.14	0.02	0.36	0.08	0.01	0.12
Avail Cap(c_a), veh/h	674	1855	827	526	1901	848	471	690	308	454	639	285
HCM Platoon Ratio	1.00	1.00	1.00	0.33	0.33	0.33	1.00	1.00	1.00	1.00	1.00	1.00
Upstream Filter(I)	1.00	1.00	1.00	0.99	0.99	0.99	1.00	1.00	1.00	1.00	1.00	1.00
Uniform Delay (d), s/veh	12.0	15.5	13.6	12.3	25.3	22.3	36.3	37.2	39.8	37.1	38.4	39.2
Incr Delay (d2), s/veh	0.1	0.4	0.2	0.2	0.2	0.1	0.2	0.1	3.3	0.1	0.0	0.9
Initial Q Delay(d3),s/veh	0.0	0.0	0.0	0.0	0.0	0.0	0.0	0.0	0.0	0.0	0.0	0.0
%ile BackOfQ(50%),veh/ln	0.8	4.3	0.9	1.4	3.9	0.4	1.2	0.2	3.0	0.6	0.1	0.9
Unsig. Movement Delay, s/veh												
LnGrp Delay(d),s/veh	12.1	16.0	13.8	12.6	25.5	22.4	36.5	37.2	43.1	37.2	38.4	40.0
LnGrp LOS	B	B	B	B	C	C	D	D	D	D	D	D
Approach Vol, veh/h		714			439			180				65
Approach Delay, s/veh		15.4			22.0			40.7				38.8
Approach LOS		B			C			D				D
Timer - Assigned Phs	1	2	3	4	5	6	7	8				
Phs Duration (G+Y+Rc), s	11.2	65.5	8.7	28.6	9.7	67.0	10.3	27.0				
Change Period (Y+Rc), s	6.0	6.0	6.5	6.5	6.0	6.0	6.5	6.5				
Max Green Setting (Gmax), s	8.0	50.0	10.5	20.5	8.0	50.0	10.5	20.5				
Max Q Clear Time (g_c+I1), s	5.3	12.5	3.3	9.0	4.1	10.3	4.7	4.0				
Green Ext Time (p_c), s	0.1	4.7	0.0	0.3	0.0	2.2	0.0	0.1				
Intersection Summary												
HCM 6th Ctrl Delay					21.8							
HCM 6th LOS					C							

Timings
3: Chapel Ridge Dr & Old Ranch Rd

2045 Total AM

09/06/2023

Lane Group	EBL	EBT	EBR	WBL	WBT	WBR	NBL	NBT	NBR	SBL	SBT	SBR
Lane Configurations												
Traffic Volume (vph)	57	534	72	153	926	37	92	10	215	118	19	169
Future Volume (vph)	57	534	72	153	926	37	92	10	215	118	19	169
Turn Type	pm+pt	NA	Perm	pm+pt	NA	Perm	pm+pt	NA	Perm	pm+pt	NA	Perm
Protected Phases	5	2		1	6		7	4		3	8	
Permitted Phases	2		2	6		6	4		4	8		8
Detector Phase	5	2	2	1	6	6	7	4	4	3	8	8
Switch Phase												
Minimum Initial (s)	4.0	6.0	6.0	4.0	6.0	6.0	4.0	4.0	4.0	4.0	4.0	4.0
Minimum Split (s)	10.0	24.0	24.0	10.0	24.0	24.0	10.5	24.5	24.5	10.5	24.5	24.5
Total Split (s)	14.0	56.0	56.0	14.0	56.0	56.0	17.0	27.0	27.0	17.0	27.0	27.0
Total Split (%)	12.3%	49.1%	49.1%	12.3%	49.1%	49.1%	14.9%	23.7%	23.7%	14.9%	23.7%	23.7%
Yellow Time (s)	4.0	4.0	4.0	4.0	4.0	4.0	4.5	4.5	4.5	4.5	4.5	4.5
All-Red Time (s)	2.0	2.0	2.0	2.0	2.0	2.0	2.0	2.0	2.0	2.0	2.0	2.0
Lost Time Adjust (s)	0.0	0.0	0.0	0.0	0.0	0.0	0.0	0.0	0.0	0.0	0.0	0.0
Total Lost Time (s)	6.0	6.0	6.0	6.0	6.0	6.0	6.5	6.5	6.5	6.5	6.5	6.5
Lead/Lag	Lead	Lag	Lag	Lead	Lag	Lag	Lead	Lag	Lag	Lead	Lag	Lag
Lead-Lag Optimize?	Yes	Yes	Yes	Yes	Yes	Yes	Yes	Yes	Yes	Yes	Yes	Yes
Recall Mode	None	C-Max	C-Max	None	C-Max	C-Max	None	Max	Max	None	Max	Max
Act Effct Green (s)	57.2	50.0	50.0	59.5	53.1	53.1	30.5	21.0	21.0	31.5	21.4	21.4
Actuated g/C Ratio	0.50	0.44	0.44	0.52	0.47	0.47	0.27	0.18	0.18	0.28	0.19	0.19
v/c Ratio	0.33	0.43	0.12	0.50	0.70	0.06	0.29	0.02	0.53	0.36	0.04	0.45
Control Delay	15.9	23.2	0.5	28.7	39.2	1.0	29.9	38.7	9.0	31.3	38.8	8.9
Queue Delay	0.0	0.0	0.0	0.0	0.0	0.0	0.0	0.0	0.0	0.0	0.0	0.0
Total Delay	15.9	23.2	0.5	28.7	39.2	1.0	29.9	38.7	9.0	31.3	38.8	8.9
LOS	B	C	A	C	D	A	C	D	A	C	D	A
Approach Delay		20.1			36.5			16.0			19.4	
Approach LOS		C			D			B			B	

Intersection Summary

Cycle Length: 114
 Actuated Cycle Length: 114
 Offset: 33 (29%), Referenced to phase 2:EBTL and 6:WBTL, Start of Green
 Natural Cycle: 80
 Control Type: Actuated-Coordinated
 Maximum v/c Ratio: 0.70
 Intersection Signal Delay: 27.1
 Intersection LOS: C
 Intersection Capacity Utilization 57.6%
 ICU Level of Service B
 Analysis Period (min) 15

Splits and Phases: 3: Chapel Ridge Dr & Old Ranch Rd



HCM 6th Signalized Intersection Summary
3: Chapel Ridge Dr & Old Ranch Rd

2045 Total AM
09/06/2023



Movement	EBL	EBT	EBR	WBL	WBT	WBR	NBL	NBT	NBR	SBL	SBT	SBR
Lane Configurations	↘	↑↑	↗	↘	↑↑	↗	↘	↑↑	↗	↘	↑↑	↗
Traffic Volume (veh/h)	57	534	72	153	926	37	92	10	215	118	19	169
Future Volume (veh/h)	57	534	72	153	926	37	92	10	215	118	19	169
Initial Q (Qb), veh	0	0	0	0	0	0	0	0	0	0	0	0
Ped-Bike Adj(A_pbT)	1.00		1.00	1.00		1.00	1.00		1.00	1.00		1.00
Parking Bus, Adj	1.00	1.00	1.00	1.00	1.00	1.00	1.00	1.00	1.00	1.00	1.00	1.00
Work Zone On Approach		No			No			No			No	
Adj Sat Flow, veh/h/ln	1870	1870	1870	1870	1870	1870	1870	1870	1870	1870	1870	1870
Adj Flow Rate, veh/h	71	668	90	191	1158	46	115	12	269	148	24	211
Peak Hour Factor	0.80	0.80	0.80	0.80	0.80	0.80	0.80	0.80	0.80	0.80	0.80	0.80
Percent Heavy Veh, %	2	2	2	2	2	2	2	2	2	2	2	2
Cap, veh/h	207	1588	708	414	1712	764	390	639	285	407	695	310
Arrive On Green	0.04	0.45	0.45	0.02	0.16	0.16	0.07	0.18	0.18	0.08	0.20	0.20
Sat Flow, veh/h	1781	3554	1585	1781	3554	1585	1781	3554	1585	1781	3554	1585
Grp Volume(v), veh/h	71	668	90	191	1158	46	115	12	269	148	24	211
Grp Sat Flow(s),veh/h/ln	1781	1777	1585	1781	1777	1585	1781	1777	1585	1781	1777	1585
Q Serve(g_s), s	2.5	14.6	3.8	6.4	35.0	2.8	5.9	0.3	19.1	7.6	0.6	14.1
Cycle Q Clear(g_c), s	2.5	14.6	3.8	6.4	35.0	2.8	5.9	0.3	19.1	7.6	0.6	14.1
Prop In Lane	1.00		1.00	1.00		1.00	1.00		1.00	1.00		1.00
Lane Grp Cap(c), veh/h	207	1588	708	414	1712	764	390	639	285	407	695	310
V/C Ratio(X)	0.34	0.42	0.13	0.46	0.68	0.06	0.29	0.02	0.94	0.36	0.03	0.68
Avail Cap(c_a), veh/h	269	1588	708	414	1712	764	433	639	285	422	695	310
HCM Platoon Ratio	1.00	1.00	1.00	0.33	0.33	0.33	1.00	1.00	1.00	1.00	1.00	1.00
Upstream Filter(l)	1.00	1.00	1.00	0.87	0.87	0.87	1.00	1.00	1.00	1.00	1.00	1.00
Uniform Delay (d), s/veh	20.9	21.5	18.5	17.0	39.6	26.0	34.5	38.5	46.2	33.7	37.1	42.6
Incr Delay (d2), s/veh	1.0	0.8	0.4	0.7	1.9	0.1	0.4	0.1	40.7	0.5	0.1	11.5
Initial Q Delay(d3),s/veh	0.0	0.0	0.0	0.0	0.0	0.0	0.0	0.0	0.0	0.0	0.0	0.0
%ile BackOfQ(50%),veh/ln	1.1	6.2	1.5	2.9	17.1	1.1	2.6	0.1	10.7	3.4	0.3	6.5
Unsig. Movement Delay, s/veh												
LnGrp Delay(d),s/veh	21.9	22.3	18.9	17.7	41.4	26.1	34.9	38.5	86.8	34.3	37.2	54.0
LnGrp LOS	C	C	B	B	D	C	C	D	F	C	D	D
Approach Vol, veh/h		829			1395			396			383	
Approach Delay, s/veh		21.9			37.7			70.3			45.3	
Approach LOS		C			D			E			D	
Timer - Assigned Phs	1	2	3	4	5	6	7	8				
Phs Duration (G+Y+Rc), s	14.0	56.9	16.1	27.0	10.0	60.9	14.3	28.8				
Change Period (Y+Rc), s	6.0	6.0	6.5	6.5	6.0	6.0	6.5	6.5				
Max Green Setting (Gmax), s	8.0	50.0	10.5	20.5	8.0	50.0	10.5	20.5				
Max Q Clear Time (g_c+I1), s	8.4	16.6	9.6	21.1	4.5	37.0	7.9	16.1				
Green Ext Time (p_c), s	0.0	5.6	0.0	0.0	0.0	6.9	0.1	0.3				
Intersection Summary												
HCM 6th Ctrl Delay					38.6							
HCM 6th LOS					D							

Timings
3: Chapel Ridge Dr & Old Ranch Rd

2045 Total PM
09/06/2023

Lane Group	EBL	EBT	EBR	WBL	WBT	WBR	NBL	NBT	NBR	SBL	SBT	SBR
Lane Configurations												
Traffic Volume (vph)	185	568	68	111	304	104	51	26	111	74	12	101
Future Volume (vph)	185	568	68	111	304	104	51	26	111	74	12	101
Turn Type	pm+pt	NA	Perm	pm+pt	NA	Perm	pm+pt	NA	Perm	pm+pt	NA	Perm
Protected Phases	5	2		1	6		7	4		3	8	
Permitted Phases	2		2	6		6	4		4	8		8
Detector Phase	5	2	2	1	6	6	7	4	4	3	8	8
Switch Phase												
Minimum Initial (s)	4.0	6.0	6.0	4.0	6.0	6.0	4.0	4.0	4.0	4.0	4.0	4.0
Minimum Split (s)	10.0	24.0	24.0	10.0	24.0	24.0	10.5	24.5	24.5	10.5	24.5	24.5
Total Split (s)	14.0	56.0	56.0	14.0	56.0	56.0	17.0	27.0	27.0	17.0	27.0	27.0
Total Split (%)	12.3%	49.1%	49.1%	12.3%	49.1%	49.1%	14.9%	23.7%	23.7%	14.9%	23.7%	23.7%
Yellow Time (s)	4.0	4.0	4.0	4.0	4.0	4.0	4.5	4.5	4.5	4.5	4.5	4.5
All-Red Time (s)	2.0	2.0	2.0	2.0	2.0	2.0	2.0	2.0	2.0	2.0	2.0	2.0
Lost Time Adjust (s)	0.0	0.0	0.0	0.0	0.0	0.0	0.0	0.0	0.0	0.0	0.0	0.0
Total Lost Time (s)	6.0	6.0	6.0	6.0	6.0	6.0	6.5	6.5	6.5	6.5	6.5	6.5
Lead/Lag	Lead	Lag	Lag	Lead	Lag	Lag	Lead	Lag	Lag	Lead	Lag	Lag
Lead-Lag Optimize?	Yes	Yes	Yes	Yes	Yes	Yes	Yes	Yes	Yes	Yes	Yes	Yes
Recall Mode	None	C-Max	C-Max	None	C-Max	C-Max	None	Max	Max	None	Max	Max
Act Effct Green (s)	58.3	50.3	50.3	57.7	50.0	50.0	31.6	24.9	24.9	33.0	25.6	25.6
Actuated g/C Ratio	0.51	0.44	0.44	0.51	0.44	0.44	0.28	0.22	0.22	0.29	0.22	0.22
v/c Ratio	0.32	0.37	0.09	0.26	0.20	0.13	0.13	0.03	0.24	0.18	0.02	0.22
Control Delay	14.3	22.1	0.2	15.6	20.3	3.3	27.7	38.3	4.1	28.3	37.7	3.1
Queue Delay	0.0	0.0	0.0	0.0	0.0	0.0	0.0	0.0	0.0	0.0	0.0	0.0
Total Delay	14.3	22.1	0.2	15.6	20.3	3.3	27.7	38.3	4.1	28.3	37.7	3.1
LOS	B	C	A	B	C	A	C	D	A	C	D	A
Approach Delay		18.6			15.9			15.2			15.3	
Approach LOS		B			B			B			B	

Intersection Summary

Cycle Length: 114
 Actuated Cycle Length: 114
 Offset: 33 (29%), Referenced to phase 2:EBTL and 6:WBTL, Start of Green
 Natural Cycle: 70
 Control Type: Actuated-Coordinated
 Maximum v/c Ratio: 0.37
 Intersection Signal Delay: 17.0
 Intersection LOS: B
 Intersection Capacity Utilization 48.0%
 ICU Level of Service A
 Analysis Period (min) 15

Splits and Phases: 3: Chapel Ridge Dr & Old Ranch Rd



HCM 6th Signalized Intersection Summary
 3: Chapel Ridge Dr & Old Ranch Rd

2045 Total PM
 09/06/2023



Movement	EBL	EBT	EBR	WBL	WBT	WBR	NBL	NBT	NBR	SBL	SBT	SBR
Lane Configurations	↘	↑↑	↗	↘	↑↑	↗	↘	↑↑	↗	↘	↑↑	↗
Traffic Volume (veh/h)	185	568	68	111	304	104	51	26	111	74	12	101
Future Volume (veh/h)	185	568	68	111	304	104	51	26	111	74	12	101
Initial Q (Qb), veh	0	0	0	0	0	0	0	0	0	0	0	0
Ped-Bike Adj(A_pbT)	1.00		1.00	1.00		1.00	1.00		1.00	1.00		1.00
Parking Bus, Adj	1.00	1.00	1.00	1.00	1.00	1.00	1.00	1.00	1.00	1.00	1.00	1.00
Work Zone On Approach		No			No			No			No	
Adj Sat Flow, veh/h/ln	1870	1870	1870	1870	1870	1870	1870	1870	1870	1870	1870	1870
Adj Flow Rate, veh/h	187	574	69	112	307	105	52	26	112	75	12	102
Peak Hour Factor	0.99	0.99	0.99	0.99	0.99	0.99	0.99	0.99	0.99	0.99	0.99	0.99
Percent Heavy Veh, %	2	2	2	2	2	2	2	2	2	2	2	2
Cap, veh/h	586	1798	802	471	1720	767	353	639	285	365	687	307
Arrive On Green	0.07	0.51	0.51	0.02	0.16	0.16	0.03	0.18	0.18	0.05	0.19	0.19
Sat Flow, veh/h	1781	3554	1585	1781	3554	1585	1781	3554	1585	1781	3554	1585
Grp Volume(v), veh/h	187	574	69	112	307	105	52	26	112	75	12	102
Grp Sat Flow(s),veh/h/ln	1781	1777	1585	1781	1777	1585	1781	1777	1585	1781	1777	1585
Q Serve(g_s), s	6.0	10.8	2.6	3.5	8.5	6.5	2.7	0.7	7.1	3.9	0.3	6.3
Cycle Q Clear(g_c), s	6.0	10.8	2.6	3.5	8.5	6.5	2.7	0.7	7.1	3.9	0.3	6.3
Prop In Lane	1.00		1.00	1.00		1.00	1.00		1.00	1.00		1.00
Lane Grp Cap(c), veh/h	586	1798	802	471	1720	767	353	639	285	365	687	307
V/C Ratio(X)	0.32	0.32	0.09	0.24	0.18	0.14	0.15	0.04	0.39	0.21	0.02	0.33
Avail Cap(c_a), veh/h	587	1798	802	511	1720	767	457	639	285	445	687	307
HCM Platoon Ratio	1.00	1.00	1.00	0.33	0.33	0.33	1.00	1.00	1.00	1.00	1.00	1.00
Upstream Filter(l)	1.00	1.00	1.00	0.99	0.99	0.99	1.00	1.00	1.00	1.00	1.00	1.00
Uniform Delay (d), s/veh	13.1	16.6	14.5	14.1	28.3	27.4	36.3	38.6	41.3	35.6	37.2	39.6
Incr Delay (d2), s/veh	0.3	0.5	0.2	0.3	0.2	0.4	0.2	0.1	4.0	0.3	0.0	2.9
Initial Q Delay(d3),s/veh	0.0	0.0	0.0	0.0	0.0	0.0	0.0	0.0	0.0	0.0	0.0	0.0
%ile BackOfQ(50%),veh/ln	2.4	4.5	1.0	1.5	4.0	2.7	1.2	0.3	3.1	1.7	0.1	2.7
Unsig. Movement Delay, s/veh												
LnGrp Delay(d),s/veh	13.4	17.1	14.8	14.4	28.5	27.8	36.5	38.7	45.3	35.8	37.3	42.5
LnGrp LOS	B	B	B	B	C	C	D	D	D	D	D	D
Approach Vol, veh/h		830			524			190			189	
Approach Delay, s/veh		16.0			25.4			42.0			39.5	
Approach LOS		B			C			D			D	
Timer - Assigned Phs	1	2	3	4	5	6	7	8				
Phs Duration (G+Y+Rc), s	11.4	63.7	11.9	27.0	13.9	61.2	10.3	28.6				
Change Period (Y+Rc), s	6.0	6.0	6.5	6.5	6.0	6.0	6.5	6.5				
Max Green Setting (Gmax), s	8.0	50.0	10.5	20.5	8.0	50.0	10.5	20.5				
Max Q Clear Time (g_c+I1), s	5.5	12.8	5.9	9.1	8.0	10.5	4.7	8.3				
Green Ext Time (p_c), s	0.1	4.7	0.1	0.3	0.0	2.5	0.0	0.2				
Intersection Summary												
HCM 6th Ctrl Delay				24.3								
HCM 6th LOS				C								

Timings
4: Powers Blvd SB Ramp & Old Ranch Rd

2023 Existing AM
09/06/2023

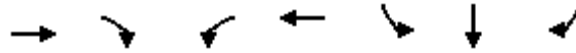

Lane Group	EBT	EBR	WBL	WBT	SBL	SBT	SBR
Lane Configurations	↑↑	↑	↵	↑↑	↵	↕	↵
Traffic Volume (vph)	367	240	314	740	111	0	48
Future Volume (vph)	367	240	314	740	111	0	48
Turn Type	NA	Free	pm+pt	NA	Split	NA	Free
Protected Phases	4		3	8	6	6	
Permitted Phases		Free	8				Free
Detector Phase	4		3	8	6	6	
Switch Phase							
Minimum Initial (s)	15.0		4.0	15.0	6.0	6.0	
Minimum Split (s)	24.0		10.0	24.0	24.5	24.5	
Total Split (s)	70.0		16.0	86.0	28.0	28.0	
Total Split (%)	61.4%		14.0%	75.4%	24.6%	24.6%	
Yellow Time (s)	4.0		4.0	4.0	4.5	4.5	
All-Red Time (s)	2.0		2.0	2.0	2.0	2.0	
Lost Time Adjust (s)	0.0		0.0	0.0	0.0	0.0	
Total Lost Time (s)	6.0		6.0	6.0	6.5	6.5	
Lead/Lag	Lag		Lead				
Lead-Lag Optimize?	Yes		Yes				
Recall Mode	C-Max		None	C-Max	Max	Max	
Act Effect Green (s)	64.0	114.0	80.0	80.0	21.5	21.5	114.0
Actuated g/C Ratio	0.56	1.00	0.70	0.70	0.19	0.19	1.00
v/c Ratio	0.24	0.20	0.64	0.39	0.24	0.20	0.04
Control Delay	7.5	0.3	15.8	11.0	41.6	8.0	0.0
Queue Delay	0.0	0.0	0.0	0.0	0.0	0.0	0.0
Total Delay	7.5	0.3	15.8	11.0	41.6	8.0	0.0
LOS	A	A	B	B	D	A	A
Approach Delay	4.7			12.5		18.1	
Approach LOS	A			B		B	

Intersection Summary

Cycle Length: 114
 Actuated Cycle Length: 114
 Offset: 56 (49%), Referenced to phase 4:EBT and 8:WBTL, Start of Green
 Natural Cycle: 60
 Control Type: Actuated-Coordinated
 Maximum v/c Ratio: 0.64
 Intersection Signal Delay: 10.3
 Intersection Capacity Utilization 50.3%
 Analysis Period (min) 15
 Intersection LOS: B
 ICU Level of Service A

Splits and Phases: 4: Powers Blvd SB Ramp & Old Ranch Rd

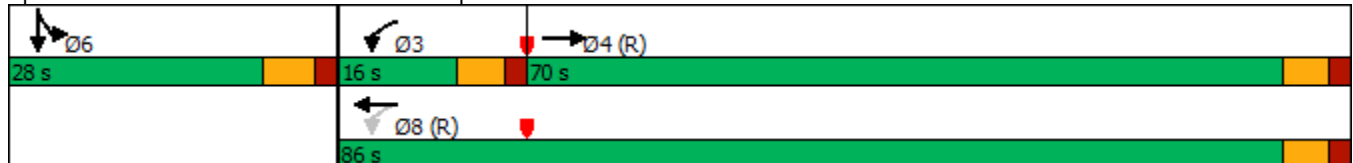

HCM 6th Signalized Intersection Summary
4: Powers Blvd SB Ramp & Old Ranch Rd

2023 Existing AM
09/06/2023



Movement	EBL	EBT	EBR	WBL	WBT	WBR	NBL	NBT	NBR	SBL	SBT	SBR
Lane Configurations		↑↑	↗	↘	↑↑					↘	↕	↗
Traffic Volume (veh/h)	0	367	240	314	740	0	0	0	0	111	0	48
Future Volume (veh/h)	0	367	240	314	740	0	0	0	0	111	0	48
Initial Q (Qb), veh	0	0	0	0	0	0				0	0	0
Ped-Bike Adj(A_pbT)	1.00		1.00	1.00		1.00				1.00		1.00
Parking Bus, Adj	1.00	1.00	1.00	1.00	1.00	1.00				1.00	1.00	1.00
Work Zone On Approach		No			No						No	
Adj Sat Flow, veh/h/ln	0	1870	1870	1870	1870	0				1870	1870	1870
Adj Flow Rate, veh/h	0	477	0	408	961	0				163	0	0
Peak Hour Factor	0.77	0.77	0.77	0.77	0.77	0.77				0.77	0.77	0.77
Percent Heavy Veh, %	0	2	2	2	2	0				2	2	2
Cap, veh/h	0	1995		734	2494	0				672	0	
Arrive On Green	0.00	1.00	0.00	0.12	0.93	0.00				0.19	0.00	0.00
Sat Flow, veh/h	0	3647	1585	1781	3647	0				3563	0	1585
Grp Volume(v), veh/h	0	477	0	408	961	0				163	0	0
Grp Sat Flow(s),veh/h/ln	0	1777	1585	1781	1777	0				1781	0	1585
Q Serve(g_s), s	0.0	0.0	0.0	10.0	3.2	0.0				4.4	0.0	0.0
Cycle Q Clear(g_c), s	0.0	0.0	0.0	10.0	3.2	0.0				4.4	0.0	0.0
Prop In Lane	0.00		1.00	1.00		0.00				1.00		1.00
Lane Grp Cap(c), veh/h	0	1995		734	2494	0				672	0	
V/C Ratio(X)	0.00	0.24		0.56	0.39	0.00				0.24	0.00	
Avail Cap(c_a), veh/h	0	1995		734	2494	0				672	0	
HCM Platoon Ratio	1.00	2.00	2.00	1.33	1.33	1.00				1.00	1.00	1.00
Upstream Filter(I)	0.00	0.96	0.00	0.78	0.78	0.00				1.00	0.00	0.00
Uniform Delay (d), s/veh	0.0	0.0	0.0	8.4	1.2	0.0				39.3	0.0	0.0
Incr Delay (d2), s/veh	0.0	0.3	0.0	0.7	0.4	0.0				0.9	0.0	0.0
Initial Q Delay(d3),s/veh	0.0	0.0	0.0	0.0	0.0	0.0				0.0	0.0	0.0
%ile BackOfQ(50%),veh/ln	0.0	0.1	0.0	4.0	0.9	0.0				2.0	0.0	0.0
Unsig. Movement Delay, s/veh												
LnGrp Delay(d),s/veh	0.0	0.3	0.0	9.1	1.6	0.0				40.2	0.0	0.0
LnGrp LOS	A	A		A	A	A				D	A	
Approach Vol, veh/h		477			1369							163
Approach Delay, s/veh		0.3			3.8							40.2
Approach LOS		A			A							D
Timer - Assigned Phs			3	4		6		8				
Phs Duration (G+Y+Rc), s			16.0	70.0		28.0		86.0				
Change Period (Y+Rc), s			6.0	6.0		6.5		6.0				
Max Green Setting (Gmax), s			10.0	64.0		21.5		80.0				
Max Q Clear Time (g_c+I1), s			12.0	2.0		6.4		5.2				
Green Ext Time (p_c), s			0.0	3.7		0.4		9.1				
Intersection Summary												
HCM 6th Ctrl Delay			5.9									
HCM 6th LOS			A									
Notes												
User approved volume balancing among the lanes for turning movement.												
Unsignalized Delay for [EBR, SBR] is excluded from calculations of the approach delay and intersection delay.												

Timings
4: Powers Blvd SB Ramp & Old Ranch Rd

2023 Existing PM
09/06/2023

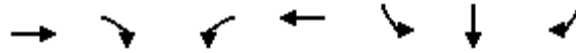

Lane Group	EBT	EBR	WBL	WBT	SBL	SBT	SBR
Lane Configurations	↑↑	↑	↵	↑↑	↵	↕	↵
Traffic Volume (vph)	296	213	209	296	92	2	31
Future Volume (vph)	296	213	209	296	92	2	31
Turn Type	NA	Free	pm+pt	NA	Split	NA	Free
Protected Phases	4		3	8	6	6	
Permitted Phases		Free	8				Free
Detector Phase	4		3	8	6	6	
Switch Phase							
Minimum Initial (s)	15.0		4.0	15.0	6.0	6.0	
Minimum Split (s)	24.0		10.0	24.0	24.5	24.5	
Total Split (s)	70.0		16.0	86.0	28.0	28.0	
Total Split (%)	61.4%		14.0%	75.4%	24.6%	24.6%	
Yellow Time (s)	4.0		4.0	4.0	4.5	4.5	
All-Red Time (s)	2.0		2.0	2.0	2.0	2.0	
Lost Time Adjust (s)	0.0		0.0	0.0	0.0	0.0	
Total Lost Time (s)	6.0		6.0	6.0	6.5	6.5	
Lead/Lag	Lag		Lead				
Lead-Lag Optimize?	Yes		Yes				
Recall Mode	C-Max		None	C-Max	Max	Max	
Act Effct Green (s)	64.6	114.0	80.0	80.0	21.5	21.5	114.0
Actuated g/C Ratio	0.57	1.00	0.70	0.70	0.19	0.19	1.00
v/c Ratio	0.15	0.14	0.29	0.12	0.16	0.16	0.02
Control Delay	3.7	0.3	9.3	7.8	40.3	39.2	0.0
Queue Delay	0.0	0.0	0.0	0.0	0.0	0.0	0.0
Total Delay	3.7	0.3	9.3	7.8	40.3	39.2	0.0
LOS	A	A	A	A	D	D	A
Approach Delay	2.3			8.4		30.9	
Approach LOS	A			A		C	

Intersection Summary

Cycle Length: 114
 Actuated Cycle Length: 114
 Offset: 56 (49%), Referenced to phase 4:EBT and 8:WBTL, Start of Green
 Natural Cycle: 60
 Control Type: Actuated-Coordinated
 Maximum v/c Ratio: 0.29
 Intersection Signal Delay: 8.1
 Intersection Capacity Utilization 44.5%
 Analysis Period (min) 15
 Intersection LOS: A
 ICU Level of Service A

Splits and Phases: 4: Powers Blvd SB Ramp & Old Ranch Rd

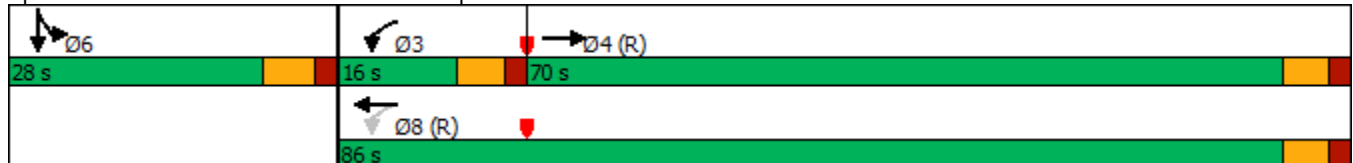

HCM 6th Signalized Intersection Summary
4: Powers Blvd SB Ramp & Old Ranch Rd

2023 Existing PM
09/06/2023



Movement	EBL	EBT	EBR	WBL	WBT	WBR	NBL	NBT	NBR	SBL	SBT	SBR
Lane Configurations		↑↑	↑	↑	↑↑					↑	↑	↑
Traffic Volume (veh/h)	0	296	213	209	296	0	0	0	0	92	2	31
Future Volume (veh/h)	0	296	213	209	296	0	0	0	0	92	2	31
Initial Q (Qb), veh	0	0	0	0	0	0				0	0	0
Ped-Bike Adj(A_pbT)	1.00		1.00	1.00		1.00				1.00		1.00
Parking Bus, Adj	1.00	1.00	1.00	1.00	1.00	1.00				1.00	1.00	1.00
Work Zone On Approach		No			No						No	
Adj Sat Flow, veh/h/ln	0	1870	1870	1870	1870	0				1870	1870	1870
Adj Flow Rate, veh/h	0	308	0	218	308	0				107	0	0
Peak Hour Factor	0.96	0.96	0.96	0.96	0.96	0.96				0.96	0.96	0.96
Percent Heavy Veh, %	0	2	2	2	2	0				2	2	2
Cap, veh/h	0	2063		807	2494	0				672	0	
Arrive On Green	0.00	1.00	0.00	0.14	1.00	0.00				0.19	0.00	0.00
Sat Flow, veh/h	0	3647	1585	1781	3647	0				3563	0	1585
Grp Volume(v), veh/h	0	308	0	218	308	0				107	0	0
Grp Sat Flow(s),veh/h/ln	0	1777	1585	1781	1777	0				1781	0	1585
Q Serve(g_s), s	0.0	0.0	0.0	5.7	0.0	0.0				2.9	0.0	0.0
Cycle Q Clear(g_c), s	0.0	0.0	0.0	5.7	0.0	0.0				2.9	0.0	0.0
Prop In Lane	0.00		1.00	1.00		0.00				1.00		1.00
Lane Grp Cap(c), veh/h	0	2063		807	2494	0				672	0	
V/C Ratio(X)	0.00	0.15		0.27	0.12	0.00				0.16	0.00	
Avail Cap(c_a), veh/h	0	2063		841	2494	0				672	0	
HCM Platoon Ratio	1.00	2.00	2.00	2.00	2.00	1.00				1.00	1.00	1.00
Upstream Filter(I)	0.00	0.98	0.00	0.97	0.97	0.00				1.00	0.00	0.00
Uniform Delay (d), s/veh	0.0	0.0	0.0	6.8	0.0	0.0				38.7	0.0	0.0
Incr Delay (d2), s/veh	0.0	0.2	0.0	0.2	0.1	0.0				0.5	0.0	0.0
Initial Q Delay(d3),s/veh	0.0	0.0	0.0	0.0	0.0	0.0				0.0	0.0	0.0
%ile BackOfQ(50%),veh/ln	0.0	0.0	0.0	1.8	0.0	0.0				1.3	0.0	0.0
Unsig. Movement Delay, s/veh												
LnGrp Delay(d),s/veh	0.0	0.2	0.0	6.9	0.1	0.0				39.2	0.0	0.0
LnGrp LOS	A	A		A	A	A				D	A	
Approach Vol, veh/h		308			526						107	
Approach Delay, s/veh		0.2			2.9						39.2	
Approach LOS		A			A						D	
Timer - Assigned Phs			3	4		6		8				
Phs Duration (G+Y+Rc), s			13.8	72.2		28.0		86.0				
Change Period (Y+Rc), s			6.0	6.0		6.5		6.0				
Max Green Setting (Gmax), s			10.0	64.0		21.5		80.0				
Max Q Clear Time (g_c+I1), s			7.7	2.0		4.9		2.0				
Green Ext Time (p_c), s			0.1	2.2		0.3		2.3				
Intersection Summary												
HCM 6th Ctrl Delay			6.1									
HCM 6th LOS			A									
Notes												
User approved volume balancing among the lanes for turning movement.												
Unsignalized Delay for [EBR, SBR] is excluded from calculations of the approach delay and intersection delay.												

Timings
4: Powers Blvd SB Ramp & Old Ranch Rd

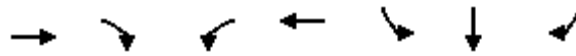

Lane Group	EBT	EBR	WBL	WBT	SBL	SBT	SBR
Lane Configurations	↑↑	↑	↵	↑↑	↵	↕	↵
Traffic Volume (vph)	378	247	323	762	114	0	49
Future Volume (vph)	378	247	323	762	114	0	49
Turn Type	NA	Free	pm+pt	NA	Split	NA	Free
Protected Phases	4		3	8	6	6	
Permitted Phases		Free	8				Free
Detector Phase	4		3	8	6	6	
Switch Phase							
Minimum Initial (s)	15.0		4.0	15.0	6.0	6.0	
Minimum Split (s)	24.0		10.0	24.0	24.5	24.5	
Total Split (s)	70.0		16.0	86.0	28.0	28.0	
Total Split (%)	61.4%		14.0%	75.4%	24.6%	24.6%	
Yellow Time (s)	4.0		4.0	4.0	4.5	4.5	
All-Red Time (s)	2.0		2.0	2.0	2.0	2.0	
Lost Time Adjust (s)	0.0		0.0	0.0	0.0	0.0	
Total Lost Time (s)	6.0		6.0	6.0	6.5	6.5	
Lead/Lag	Lag		Lead				
Lead-Lag Optimize?	Yes		Yes				
Recall Mode	C-Max		None	C-Max	Max	Max	
Act Effct Green (s)	64.0	114.0	80.0	80.0	21.5	21.5	114.0
Actuated g/C Ratio	0.56	1.00	0.70	0.70	0.19	0.19	1.00
v/c Ratio	0.25	0.20	0.66	0.40	0.24	0.21	0.04
Control Delay	7.4	0.3	16.6	11.1	41.7	8.4	0.0
Queue Delay	0.0	0.0	0.0	0.0	0.0	0.0	0.0
Total Delay	7.4	0.3	16.6	11.1	41.7	8.4	0.0
LOS	A	A	B	B	D	A	A
Approach Delay	4.6			12.7		18.2	
Approach LOS	A			B		B	

Intersection Summary

Cycle Length: 114
 Actuated Cycle Length: 114
 Offset: 56 (49%), Referenced to phase 4:EBT and 8:WBTL, Start of Green
 Natural Cycle: 60
 Control Type: Actuated-Coordinated
 Maximum v/c Ratio: 0.66
 Intersection Signal Delay: 10.5
 Intersection Capacity Utilization 51.1%
 Analysis Period (min) 15
 Intersection LOS: B
 ICU Level of Service A

Splits and Phases: 4: Powers Blvd SB Ramp & Old Ranch Rd

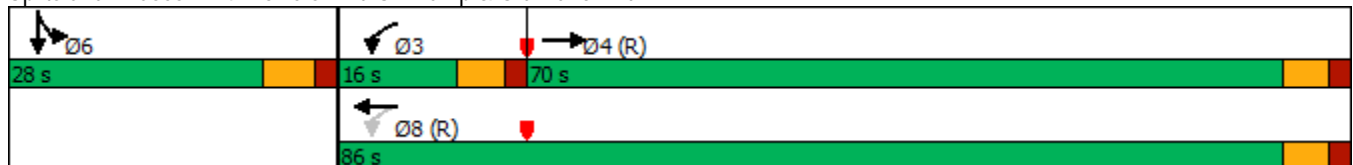

HCM 6th Signalized Intersection Summary
4: Powers Blvd SB Ramp & Old Ranch Rd

2025 Background AM

09/06/2023



Movement	EBL	EBT	EBR	WBL	WBT	WBR	NBL	NBT	NBR	SBL	SBT	SBR
Lane Configurations		↑↑	↗	↘	↑↑					↖	↕	↗
Traffic Volume (veh/h)	0	378	247	323	762	0	0	0	0	114	0	49
Future Volume (veh/h)	0	378	247	323	762	0	0	0	0	114	0	49
Initial Q (Qb), veh	0	0	0	0	0	0				0	0	0
Ped-Bike Adj(A_pbT)	1.00		1.00	1.00		1.00				1.00		1.00
Parking Bus, Adj	1.00	1.00	1.00	1.00	1.00	1.00				1.00	1.00	1.00
Work Zone On Approach		No			No						No	
Adj Sat Flow, veh/h/ln	0	1870	1870	1870	1870	0				1870	1870	1870
Adj Flow Rate, veh/h	0	491	0	419	990	0				168	0	0
Peak Hour Factor	0.77	0.77	0.77	0.77	0.77	0.77				0.77	0.77	0.77
Percent Heavy Veh, %	0	2	2	2	2	0				2	2	2
Cap, veh/h	0	1995		728	2494	0				672	0	
Arrive On Green	0.00	1.00	0.00	0.12	0.93	0.00				0.19	0.00	0.00
Sat Flow, veh/h	0	3647	1585	1781	3647	0				3563	0	1585
Grp Volume(v), veh/h	0	491	0	419	990	0				168	0	0
Grp Sat Flow(s),veh/h/ln	0	1777	1585	1781	1777	0				1781	0	1585
Q Serve(g_s), s	0.0	0.0	0.0	10.0	3.4	0.0				4.6	0.0	0.0
Cycle Q Clear(g_c), s	0.0	0.0	0.0	10.0	3.4	0.0				4.6	0.0	0.0
Prop In Lane	0.00		1.00	1.00		0.00				1.00		1.00
Lane Grp Cap(c), veh/h	0	1995		728	2494	0				672	0	
V/C Ratio(X)	0.00	0.25		0.58	0.40	0.00				0.25	0.00	
Avail Cap(c_a), veh/h	0	1995		728	2494	0				672	0	
HCM Platoon Ratio	1.00	2.00	2.00	1.33	1.33	1.00				1.00	1.00	1.00
Upstream Filter(I)	0.00	0.96	0.00	0.76	0.76	0.00				1.00	0.00	0.00
Uniform Delay (d), s/veh	0.0	0.0	0.0	8.6	1.2	0.0				39.4	0.0	0.0
Incr Delay (d2), s/veh	0.0	0.3	0.0	0.8	0.4	0.0				0.9	0.0	0.0
Initial Q Delay(d3),s/veh	0.0	0.0	0.0	0.0	0.0	0.0				0.0	0.0	0.0
%ile BackOfQ(50%),veh/ln	0.0	0.1	0.0	4.2	0.9	0.0				2.1	0.0	0.0
Unsig. Movement Delay, s/veh												
LnGrp Delay(d),s/veh	0.0	0.3	0.0	9.4	1.6	0.0				40.3	0.0	0.0
LnGrp LOS	A	A		A	A	A				D	A	
Approach Vol, veh/h		491			1409						168	
Approach Delay, s/veh		0.3			3.9						40.3	
Approach LOS		A			A						D	
Timer - Assigned Phs			3	4		6		8				
Phs Duration (G+Y+Rc), s			16.0	70.0		28.0		86.0				
Change Period (Y+Rc), s			6.0	6.0		6.5		6.0				
Max Green Setting (Gmax), s			10.0	64.0		21.5		80.0				
Max Q Clear Time (g_c+I1), s			12.0	2.0		6.6		5.4				
Green Ext Time (p_c), s			0.0	3.8		0.4		9.5				
Intersection Summary												
HCM 6th Ctrl Delay			6.0									
HCM 6th LOS			A									
Notes												
User approved volume balancing among the lanes for turning movement.												
Unsignalized Delay for [EBR, SBR] is excluded from calculations of the approach delay and intersection delay.												

Timings
4: Powers Blvd SB Ramp & Old Ranch Rd

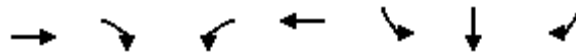

Lane Group	EBT	EBR	WBL	WBT	SBL	SBT	SBR
Lane Configurations	↑↑	↑	↑	↑↑	↑	↕	↑
Traffic Volume (vph)	305	219	215	305	95	2	32
Future Volume (vph)	305	219	215	305	95	2	32
Turn Type	NA	Free	pm+pt	NA	Split	NA	Free
Protected Phases	4		3	8	6	6	
Permitted Phases		Free	8				Free
Detector Phase	4		3	8	6	6	
Switch Phase							
Minimum Initial (s)	15.0		4.0	15.0	6.0	6.0	
Minimum Split (s)	24.0		10.0	24.0	24.5	24.5	
Total Split (s)	70.0		16.0	86.0	28.0	28.0	
Total Split (%)	61.4%		14.0%	75.4%	24.6%	24.6%	
Yellow Time (s)	4.0		4.0	4.0	4.5	4.5	
All-Red Time (s)	2.0		2.0	2.0	2.0	2.0	
Lost Time Adjust (s)	0.0		0.0	0.0	0.0	0.0	
Total Lost Time (s)	6.0		6.0	6.0	6.5	6.5	
Lead/Lag	Lag		Lead				
Lead-Lag Optimize?	Yes		Yes				
Recall Mode	C-Max		None	C-Max	Max	Max	
Act Effect Green (s)	64.6	114.0	80.0	80.0	21.5	21.5	114.0
Actuated g/C Ratio	0.57	1.00	0.70	0.70	0.19	0.19	1.00
v/c Ratio	0.16	0.14	0.30	0.13	0.16	0.17	0.02
Control Delay	3.7	0.3	9.3	7.8	40.4	39.3	0.0
Queue Delay	0.0	0.0	0.0	0.0	0.0	0.0	0.0
Total Delay	3.7	0.3	9.3	7.8	40.4	39.3	0.0
LOS	A	A	A	A	D	D	A
Approach Delay	2.3			8.4		31.0	
Approach LOS	A			A		C	

Intersection Summary

Cycle Length: 114
 Actuated Cycle Length: 114
 Offset: 56 (49%), Referenced to phase 4:EBT and 8:WBTL, Start of Green
 Natural Cycle: 60
 Control Type: Actuated-Coordinated
 Maximum v/c Ratio: 0.30
 Intersection Signal Delay: 8.2
 Intersection Capacity Utilization 44.8%
 Analysis Period (min) 15

Intersection LOS: A
 ICU Level of Service A

Splits and Phases: 4: Powers Blvd SB Ramp & Old Ranch Rd

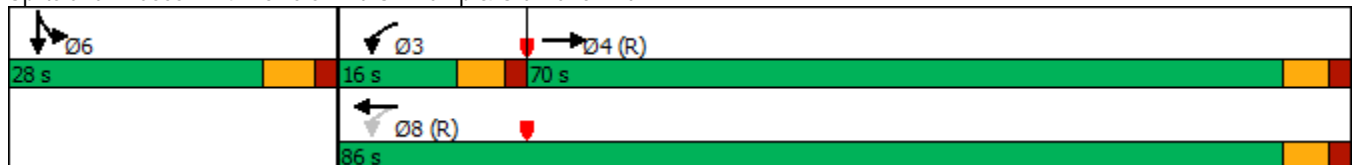

HCM 6th Signalized Intersection Summary
4: Powers Blvd SB Ramp & Old Ranch Rd

2025 Background PM

09/06/2023

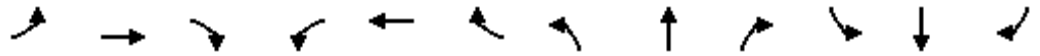

Movement	EBL	EBT	EBR	WBL	WBT	WBR	NBL	NBT	NBR	SBL	SBT	SBR
Lane Configurations		↑↑	↗	↘	↑↑					↘	↕	↗
Traffic Volume (veh/h)	0	305	219	215	305	0	0	0	0	95	2	32
Future Volume (veh/h)	0	305	219	215	305	0	0	0	0	95	2	32
Initial Q (Qb), veh	0	0	0	0	0	0				0	0	0
Ped-Bike Adj(A_pbT)	1.00		1.00	1.00		1.00				1.00		1.00
Parking Bus, Adj	1.00	1.00	1.00	1.00	1.00	1.00				1.00	1.00	1.00
Work Zone On Approach		No			No						No	
Adj Sat Flow, veh/h/ln	0	1870	1870	1870	1870	0				1870	1870	1870
Adj Flow Rate, veh/h	0	318	0	224	318	0				110	0	0
Peak Hour Factor	0.96	0.96	0.96	0.96	0.96	0.96				0.96	0.96	0.96
Percent Heavy Veh, %	0	2	2	2	2	0				2	2	2
Cap, veh/h	0	2057		803	2494	0				672	0	
Arrive On Green	0.00	1.00	0.00	0.14	1.00	0.00				0.19	0.00	0.00
Sat Flow, veh/h	0	3647	1585	1781	3647	0				3563	0	1585
Grp Volume(v), veh/h	0	318	0	224	318	0				110	0	0
Grp Sat Flow(s),veh/h/ln	0	1777	1585	1781	1777	0				1781	0	1585
Q Serve(g_s), s	0.0	0.0	0.0	5.9	0.0	0.0				2.9	0.0	0.0
Cycle Q Clear(g_c), s	0.0	0.0	0.0	5.9	0.0	0.0				2.9	0.0	0.0
Prop In Lane	0.00		1.00	1.00		0.00				1.00		1.00
Lane Grp Cap(c), veh/h	0	2057		803	2494	0				672	0	
V/C Ratio(X)	0.00	0.15		0.28	0.13	0.00				0.16	0.00	
Avail Cap(c_a), veh/h	0	2057		834	2494	0				672	0	
HCM Platoon Ratio	1.00	2.00	2.00	2.00	2.00	1.00				1.00	1.00	1.00
Upstream Filter(l)	0.00	0.98	0.00	0.97	0.97	0.00				1.00	0.00	0.00
Uniform Delay (d), s/veh	0.0	0.0	0.0	6.8	0.0	0.0				38.7	0.0	0.0
Incr Delay (d2), s/veh	0.0	0.2	0.0	0.2	0.1	0.0				0.5	0.0	0.0
Initial Q Delay(d3),s/veh	0.0	0.0	0.0	0.0	0.0	0.0				0.0	0.0	0.0
%ile BackOfQ(50%),veh/ln	0.0	0.0	0.0	1.8	0.0	0.0				1.3	0.0	0.0
Unsig. Movement Delay, s/veh												
LnGrp Delay(d),s/veh	0.0	0.2	0.0	7.0	0.1	0.0				39.2	0.0	0.0
LnGrp LOS	A	A		A	A	A				D	A	
Approach Vol, veh/h		318			542						110	
Approach Delay, s/veh		0.2			2.9						39.2	
Approach LOS		A			A						D	
Timer - Assigned Phs			3	4		6		8				
Phs Duration (G+Y+Rc), s			14.0	72.0		28.0		86.0				
Change Period (Y+Rc), s			6.0	6.0		6.5		6.0				
Max Green Setting (Gmax), s			10.0	64.0		21.5		80.0				
Max Q Clear Time (g_c+I1), s			7.9	2.0		4.9		2.0				
Green Ext Time (p_c), s			0.1	2.3		0.3		2.3				
Intersection Summary												
HCM 6th Ctrl Delay			6.1									
HCM 6th LOS			A									
Notes												
User approved volume balancing among the lanes for turning movement.												
Unsignalized Delay for [EBR, SBR] is excluded from calculations of the approach delay and intersection delay.												

Timings

2025 Total AM

4: Powers Blvd SB Ramp & Old Ranch Rd

09/06/2023

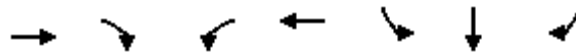

Lane Group	EBT	EBR	WBL	WBT	SBL	SBT	SBR
Lane Configurations	↑↑	↑	↵	↑↑	↵	↕	↵
Traffic Volume (vph)	404	291	323	781	114	0	55
Future Volume (vph)	404	291	323	781	114	0	55
Turn Type	NA	Free	pm+pt	NA	Split	NA	Free
Protected Phases	4		3	8	6	6	
Permitted Phases		Free	8				Free
Detector Phase	4		3	8	6	6	
Switch Phase							
Minimum Initial (s)	15.0		4.0	15.0	6.0	6.0	
Minimum Split (s)	24.0		10.0	24.0	24.5	24.5	
Total Split (s)	70.0		16.0	86.0	28.0	28.0	
Total Split (%)	61.4%		14.0%	75.4%	24.6%	24.6%	
Yellow Time (s)	4.0		4.0	4.0	4.5	4.5	
All-Red Time (s)	2.0		2.0	2.0	2.0	2.0	
Lost Time Adjust (s)	0.0		0.0	0.0	0.0	0.0	
Total Lost Time (s)	6.0		6.0	6.0	6.5	6.5	
Lead/Lag	Lag		Lead				
Lead-Lag Optimize?	Yes		Yes				
Recall Mode	C-Max		None	C-Max	Max	Max	
Act Effect Green (s)	64.0	114.0	80.0	80.0	21.5	21.5	114.0
Actuated g/C Ratio	0.56	1.00	0.70	0.70	0.19	0.19	1.00
v/c Ratio	0.26	0.24	0.69	0.41	0.25	0.21	0.04
Control Delay	10.5	0.4	17.1	11.0	41.8	8.4	0.1
Queue Delay	0.0	0.0	0.0	0.0	0.0	0.0	0.0
Total Delay	10.5	0.4	17.1	11.0	41.8	8.4	0.1
LOS	B	A	B	B	D	A	A
Approach Delay	6.2			12.7		17.9	
Approach LOS	A			B		B	

Intersection Summary

Cycle Length: 114
 Actuated Cycle Length: 114
 Offset: 56 (49%), Referenced to phase 4:EBT and 8:WBTL, Start of Green
 Natural Cycle: 65
 Control Type: Actuated-Coordinated
 Maximum v/c Ratio: 0.69
 Intersection Signal Delay: 10.9
 Intersection Capacity Utilization 51.7%
 Analysis Period (min) 15
 Intersection LOS: B
 ICU Level of Service A

Splits and Phases: 4: Powers Blvd SB Ramp & Old Ranch Rd

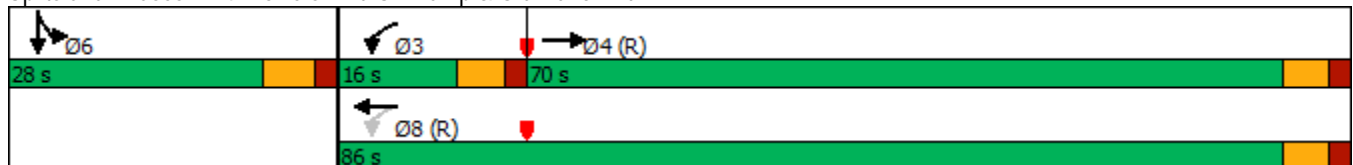

HCM 6th Signalized Intersection Summary
 4: Powers Blvd SB Ramp & Old Ranch Rd

2025 Total AM
 09/06/2023



Movement	EBL	EBT	EBR	WBL	WBT	WBR	NBL	NBT	NBR	SBL	SBT	SBR
Lane Configurations		↑↑	↑	↑	↑↑					↑	↑↓	↑
Traffic Volume (veh/h)	0	404	291	323	781	0	0	0	0	114	0	55
Future Volume (veh/h)	0	404	291	323	781	0	0	0	0	114	0	55
Initial Q (Qb), veh	0	0	0	0	0	0				0	0	0
Ped-Bike Adj(A_pbT)	1.00		1.00	1.00		1.00				1.00		1.00
Parking Bus, Adj	1.00	1.00	1.00	1.00	1.00	1.00				1.00	1.00	1.00
Work Zone On Approach		No			No						No	
Adj Sat Flow, veh/h/ln	0	1870	1870	1870	1870	0				1870	1870	1870
Adj Flow Rate, veh/h	0	525	0	419	1014	0				170	0	0
Peak Hour Factor	0.77	0.77	0.77	0.77	0.77	0.77				0.77	0.77	0.77
Percent Heavy Veh, %	0	2	2	2	2	0				2	2	2
Cap, veh/h	0	1995		712	2494	0				672	0	
Arrive On Green	0.00	1.00	0.00	0.12	0.93	0.00				0.19	0.00	0.00
Sat Flow, veh/h	0	3647	1585	1781	3647	0				3563	0	1585
Grp Volume(v), veh/h	0	525	0	419	1014	0				170	0	0
Grp Sat Flow(s),veh/h/ln	0	1777	1585	1781	1777	0				1781	0	1585
Q Serve(g_s), s	0.0	0.0	0.0	10.0	3.5	0.0				4.6	0.0	0.0
Cycle Q Clear(g_c), s	0.0	0.0	0.0	10.0	3.5	0.0				4.6	0.0	0.0
Prop In Lane	0.00		1.00	1.00		0.00				1.00		1.00
Lane Grp Cap(c), veh/h	0	1995		712	2494	0				672	0	
V/C Ratio(X)	0.00	0.26		0.59	0.41	0.00				0.25	0.00	
Avail Cap(c_a), veh/h	0	1995		712	2494	0				672	0	
HCM Platoon Ratio	1.00	2.00	2.00	1.33	1.33	1.00				1.00	1.00	1.00
Upstream Filter(I)	0.00	0.94	0.00	0.75	0.75	0.00				1.00	0.00	0.00
Uniform Delay (d), s/veh	0.0	0.0	0.0	8.6	1.2	0.0				39.4	0.0	0.0
Incr Delay (d2), s/veh	0.0	0.3	0.0	1.0	0.4	0.0				0.9	0.0	0.0
Initial Q Delay(d3),s/veh	0.0	0.0	0.0	0.0	0.0	0.0				0.0	0.0	0.0
%ile BackOfQ(50%),veh/ln	0.0	0.1	0.0	4.2	0.9	0.0				2.1	0.0	0.0
Unsig. Movement Delay, s/veh												
LnGrp Delay(d),s/veh	0.0	0.3	0.0	9.5	1.6	0.0				40.3	0.0	0.0
LnGrp LOS	A	A		A	A	A				D	A	
Approach Vol, veh/h		525			1433						170	
Approach Delay, s/veh		0.3			3.9						40.3	
Approach LOS		A			A						D	
Timer - Assigned Phs			3	4		6		8				
Phs Duration (G+Y+Rc), s			16.0	70.0		28.0		86.0				
Change Period (Y+Rc), s			6.0	6.0		6.5		6.0				
Max Green Setting (Gmax), s			10.0	64.0		21.5		80.0				
Max Q Clear Time (g_c+I1), s			12.0	2.0		6.6		5.5				
Green Ext Time (p_c), s			0.0	4.1		0.4		9.8				
Intersection Summary												
HCM 6th Ctrl Delay			5.9									
HCM 6th LOS			A									
Notes												
User approved volume balancing among the lanes for turning movement.												
Unsignalized Delay for [EBR, SBR] is excluded from calculations of the approach delay and intersection delay.												

Timings

2025 Total AM

4: Powers Blvd SB Ramp & Old Ranch Rd

09/06/2023

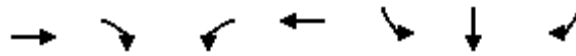

Lane Group	EBT	EBR	WBL	WBT	SBL	SBT	SBR
Lane Configurations	↑↑	↑	↵	↑↑	↵	↕	↵
Traffic Volume (vph)	404	291	323	781	114	0	55
Future Volume (vph)	404	291	323	781	114	0	55
Turn Type	NA	Free	pm+pt	NA	Split	NA	Free
Protected Phases	4		3	8	6	6	
Permitted Phases		Free	8				Free
Detector Phase	4		3	8	6	6	
Switch Phase							
Minimum Initial (s)	15.0		4.0	15.0	6.0	6.0	
Minimum Split (s)	24.0		10.0	24.0	24.5	24.5	
Total Split (s)	70.0		16.0	86.0	28.0	28.0	
Total Split (%)	61.4%		14.0%	75.4%	24.6%	24.6%	
Yellow Time (s)	4.0		4.0	4.0	4.5	4.5	
All-Red Time (s)	2.0		2.0	2.0	2.0	2.0	
Lost Time Adjust (s)	0.0		0.0	0.0	0.0	0.0	
Total Lost Time (s)	6.0		6.0	6.0	6.5	6.5	
Lead/Lag	Lag		Lead				
Lead-Lag Optimize?	Yes		Yes				
Recall Mode	C-Max		None	C-Max	Max	Max	
Act Effect Green (s)	64.0	114.0	80.0	80.0	21.5	21.5	114.0
Actuated g/C Ratio	0.56	1.00	0.70	0.70	0.19	0.19	1.00
v/c Ratio	0.26	0.24	0.69	0.41	0.25	0.21	0.04
Control Delay	10.5	0.4	17.1	11.0	41.8	8.4	0.1
Queue Delay	0.0	0.0	0.0	0.0	0.0	0.0	0.0
Total Delay	10.5	0.4	17.1	11.0	41.8	8.4	0.1
LOS	B	A	B	B	D	A	A
Approach Delay	6.2			12.7		17.9	
Approach LOS	A			B		B	

Intersection Summary

Cycle Length: 114
 Actuated Cycle Length: 114
 Offset: 56 (49%), Referenced to phase 4:EBT and 8:WBTL, Start of Green
 Natural Cycle: 65
 Control Type: Actuated-Coordinated
 Maximum v/c Ratio: 0.69
 Intersection Signal Delay: 10.9
 Intersection Capacity Utilization 51.7%
 Analysis Period (min) 15
 Intersection LOS: B
 ICU Level of Service A

Splits and Phases: 4: Powers Blvd SB Ramp & Old Ranch Rd

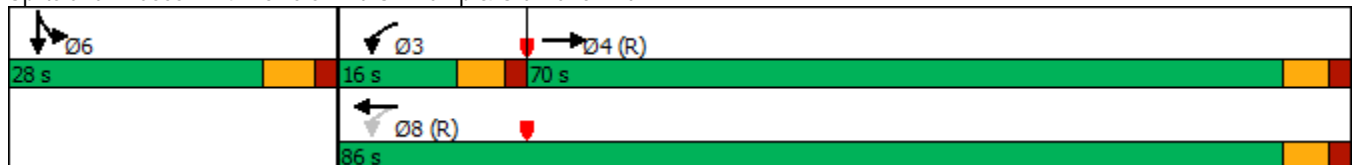

HCM 6th Signalized Intersection Summary
 4: Powers Blvd SB Ramp & Old Ranch Rd

2025 Total AM
 09/06/2023



Movement	EBL	EBT	EBR	WBL	WBT	WBR	NBL	NBT	NBR	SBL	SBT	SBR
Lane Configurations		↑↑	↑	↑	↑↑					↑	↑↓	↑
Traffic Volume (veh/h)	0	404	291	323	781	0	0	0	0	114	0	55
Future Volume (veh/h)	0	404	291	323	781	0	0	0	0	114	0	55
Initial Q (Qb), veh	0	0	0	0	0	0				0	0	0
Ped-Bike Adj(A_pbT)	1.00		1.00	1.00		1.00				1.00		1.00
Parking Bus, Adj	1.00	1.00	1.00	1.00	1.00	1.00				1.00	1.00	1.00
Work Zone On Approach		No			No						No	
Adj Sat Flow, veh/h/ln	0	1870	1870	1870	1870	0				1870	1870	1870
Adj Flow Rate, veh/h	0	525	0	419	1014	0				170	0	0
Peak Hour Factor	0.77	0.77	0.77	0.77	0.77	0.77				0.77	0.77	0.77
Percent Heavy Veh, %	0	2	2	2	2	0				2	2	2
Cap, veh/h	0	1995		712	2494	0				672	0	
Arrive On Green	0.00	1.00	0.00	0.12	0.93	0.00				0.19	0.00	0.00
Sat Flow, veh/h	0	3647	1585	1781	3647	0				3563	0	1585
Grp Volume(v), veh/h	0	525	0	419	1014	0				170	0	0
Grp Sat Flow(s),veh/h/ln	0	1777	1585	1781	1777	0				1781	0	1585
Q Serve(g_s), s	0.0	0.0	0.0	10.0	3.5	0.0				4.6	0.0	0.0
Cycle Q Clear(g_c), s	0.0	0.0	0.0	10.0	3.5	0.0				4.6	0.0	0.0
Prop In Lane	0.00		1.00	1.00		0.00				1.00		1.00
Lane Grp Cap(c), veh/h	0	1995		712	2494	0				672	0	
V/C Ratio(X)	0.00	0.26		0.59	0.41	0.00				0.25	0.00	
Avail Cap(c_a), veh/h	0	1995		712	2494	0				672	0	
HCM Platoon Ratio	1.00	2.00	2.00	1.33	1.33	1.00				1.00	1.00	1.00
Upstream Filter(I)	0.00	0.94	0.00	0.75	0.75	0.00				1.00	0.00	0.00
Uniform Delay (d), s/veh	0.0	0.0	0.0	8.6	1.2	0.0				39.4	0.0	0.0
Incr Delay (d2), s/veh	0.0	0.3	0.0	1.0	0.4	0.0				0.9	0.0	0.0
Initial Q Delay(d3),s/veh	0.0	0.0	0.0	0.0	0.0	0.0				0.0	0.0	0.0
%ile BackOfQ(50%),veh/ln	0.0	0.1	0.0	4.2	0.9	0.0				2.1	0.0	0.0
Unsig. Movement Delay, s/veh												
LnGrp Delay(d),s/veh	0.0	0.3	0.0	9.5	1.6	0.0				40.3	0.0	0.0
LnGrp LOS	A	A		A	A	A				D	A	
Approach Vol, veh/h		525			1433						170	
Approach Delay, s/veh		0.3			3.9						40.3	
Approach LOS		A			A						D	
Timer - Assigned Phs			3	4		6		8				
Phs Duration (G+Y+Rc), s			16.0	70.0		28.0		86.0				
Change Period (Y+Rc), s			6.0	6.0		6.5		6.0				
Max Green Setting (Gmax), s			10.0	64.0		21.5		80.0				
Max Q Clear Time (g_c+I1), s			12.0	2.0		6.6		5.5				
Green Ext Time (p_c), s			0.0	4.1		0.4		9.8				
Intersection Summary												
HCM 6th Ctrl Delay			5.9									
HCM 6th LOS			A									
Notes												
User approved volume balancing among the lanes for turning movement.												
Unsignalized Delay for [EBR, SBR] is excluded from calculations of the approach delay and intersection delay.												

Timings
4: Powers Blvd SB Ramp & Old Ranch Rd

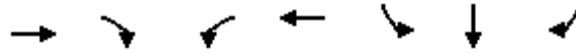

Lane Group	EBT	EBR	WBL	WBT	SBL	SBT	SBR
Lane Configurations	↑↑	↑	↘	↑↑	↘	↕	↗
Traffic Volume (vph)	509	333	436	1027	154	0	67
Future Volume (vph)	509	333	436	1027	154	0	67
Turn Type	NA	Free	pm+pt	NA	Split	NA	Free
Protected Phases	4		3	8	6	6	
Permitted Phases		Free	8				Free
Detector Phase	4		3	8	6	6	
Switch Phase							
Minimum Initial (s)	15.0		4.0	15.0	6.0	6.0	
Minimum Split (s)	24.0		10.0	24.0	24.5	24.5	
Total Split (s)	70.0		16.0	86.0	28.0	28.0	
Total Split (%)	61.4%		14.0%	75.4%	24.6%	24.6%	
Yellow Time (s)	4.0		4.0	4.0	4.5	4.5	
All-Red Time (s)	2.0		2.0	2.0	2.0	2.0	
Lost Time Adjust (s)	0.0		0.0	0.0	0.0	0.0	
Total Lost Time (s)	6.0		6.0	6.0	6.5	6.5	
Lead/Lag	Lag		Lead				
Lead-Lag Optimize?	Yes		Yes				
Recall Mode	C-Max		None	C-Max	Max	Max	
Act Effect Green (s)	64.0	114.0	80.0	80.0	21.5	21.5	114.0
Actuated g/C Ratio	0.56	1.00	0.70	0.70	0.19	0.19	1.00
v/c Ratio	0.33	0.27	1.06	0.54	0.33	0.28	0.05
Control Delay	7.1	0.4	65.8	12.2	43.5	13.6	0.1
Queue Delay	0.0	0.0	0.0	0.7	0.0	0.0	0.0
Total Delay	7.1	0.4	65.8	12.9	43.5	13.6	0.1
LOS	A	A	E	B	D	B	A
Approach Delay	4.4			28.6		21.0	
Approach LOS	A			C		C	

Intersection Summary

Cycle Length: 114
 Actuated Cycle Length: 114
 Offset: 56 (49%), Referenced to phase 4:EBT and 8:WBTL, Start of Green
 Natural Cycle: 80
 Control Type: Actuated-Coordinated
 Maximum v/c Ratio: 1.06
 Intersection Signal Delay: 19.9
 Intersection Capacity Utilization 62.4%
 Analysis Period (min) 15
 Intersection LOS: B
 ICU Level of Service B

Splits and Phases: 4: Powers Blvd SB Ramp & Old Ranch Rd

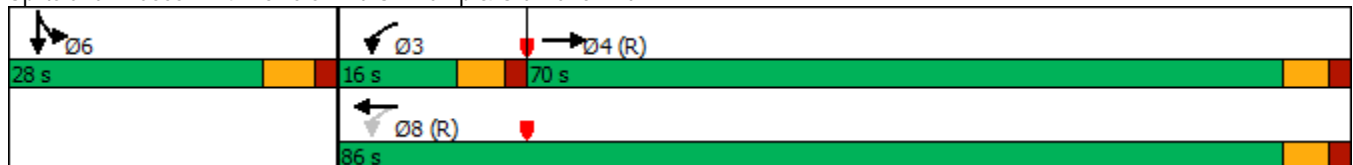

HCM 6th Signalized Intersection Summary
4: Powers Blvd SB Ramp & Old Ranch Rd

2045 Background AM

09/06/2023

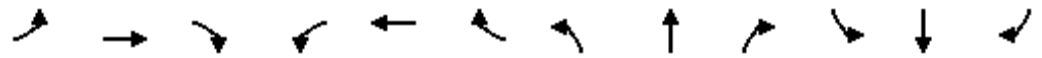

Movement	EBL	EBT	EBR	WBL	WBT	WBR	NBL	NBT	NBR	SBL	SBT	SBR
Lane Configurations		↑↑	↗	↘	↑↑					↘	↕	↗
Traffic Volume (veh/h)	0	509	333	436	1027	0	0	0	0	154	0	67
Future Volume (veh/h)	0	509	333	436	1027	0	0	0	0	154	0	67
Initial Q (Qb), veh	0	0	0	0	0	0				0	0	0
Ped-Bike Adj(A_pbT)	1.00		1.00	1.00		1.00				1.00		1.00
Parking Bus, Adj	1.00	1.00	1.00	1.00	1.00	1.00				1.00	1.00	1.00
Work Zone On Approach		No			No						No	
Adj Sat Flow, veh/h/ln	0	1870	1870	1870	1870	0				1870	1870	1870
Adj Flow Rate, veh/h	0	661	0	566	1334	0				227	0	0
Peak Hour Factor	0.77	0.77	0.77	0.77	0.77	0.77				0.77	0.77	0.77
Percent Heavy Veh, %	0	2	2	2	2	0				2	2	2
Cap, veh/h	0	1995		654	2494	0				672	0	
Arrive On Green	0.00	1.00	0.00	0.09	0.70	0.00				0.19	0.00	0.00
Sat Flow, veh/h	0	3647	1585	1781	3647	0				3563	0	1585
Grp Volume(v), veh/h	0	661	0	566	1334	0				227	0	0
Grp Sat Flow(s),veh/h/ln	0	1777	1585	1781	1777	0				1781	0	1585
Q Serve(g_s), s	0.0	0.0	0.0	10.0	20.4	0.0				6.3	0.0	0.0
Cycle Q Clear(g_c), s	0.0	0.0	0.0	10.0	20.4	0.0				6.3	0.0	0.0
Prop In Lane	0.00		1.00	1.00		0.00				1.00		1.00
Lane Grp Cap(c), veh/h	0	1995		654	2494	0				672	0	
V/C Ratio(X)	0.00	0.33		0.87	0.53	0.00				0.34	0.00	
Avail Cap(c_a), veh/h	0	1995		654	2494	0				672	0	
HCM Platoon Ratio	1.00	2.00	2.00	1.00	1.00	1.00				1.00	1.00	1.00
Upstream Filter(I)	0.00	0.91	0.00	0.47	0.47	0.00				1.00	0.00	0.00
Uniform Delay (d), s/veh	0.0	0.0	0.0	13.1	8.1	0.0				40.1	0.0	0.0
Incr Delay (d2), s/veh	0.0	0.4	0.0	6.0	0.4	0.0				1.4	0.0	0.0
Initial Q Delay(d3),s/veh	0.0	0.0	0.0	0.0	0.0	0.0				0.0	0.0	0.0
%ile BackOfQ(50%),veh/ln	0.0	0.1	0.0	5.8	7.1	0.0				2.9	0.0	0.0
Unsig. Movement Delay, s/veh												
LnGrp Delay(d),s/veh	0.0	0.4	0.0	19.1	8.5	0.0				41.4	0.0	0.0
LnGrp LOS	A	A		B	A	A				D	A	
Approach Vol, veh/h		661			1900						227	
Approach Delay, s/veh		0.4			11.7						41.4	
Approach LOS		A			B						D	
Timer - Assigned Phs			3	4		6		8				
Phs Duration (G+Y+Rc), s			16.0	70.0		28.0		86.0				
Change Period (Y+Rc), s			6.0	6.0		6.5		6.0				
Max Green Setting (Gmax), s			10.0	64.0		21.5		80.0				
Max Q Clear Time (g_c+I1), s			12.0	2.0		8.3		22.4				
Green Ext Time (p_c), s			0.0	5.4		0.6		15.2				

Intersection Summary

HCM 6th Ctrl Delay	11.4
HCM 6th LOS	B

Notes

User approved volume balancing among the lanes for turning movement.
Unsignalized Delay for [EBR, SBR] is excluded from calculations of the approach delay and intersection delay.

Timings
4: Powers Blvd SB Ramp & Old Ranch Rd

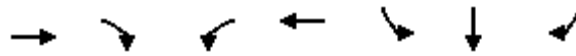

Lane Group	EBT	EBR	WBL	WBT	SBL	SBT	SBR
Lane Configurations	↑↑	↑	↵	↑↑	↵	↕	↵
Traffic Volume (vph)	411	296	290	411	128	3	43
Future Volume (vph)	411	296	290	411	128	3	43
Turn Type	NA	Free	pm+pt	NA	Split	NA	Free
Protected Phases	4		3	8	6	6	
Permitted Phases		Free	8				Free
Detector Phase	4		3	8	6	6	
Switch Phase							
Minimum Initial (s)	15.0		4.0	15.0	6.0	6.0	
Minimum Split (s)	24.0		10.0	24.0	24.5	24.5	
Total Split (s)	70.0		16.0	86.0	28.0	28.0	
Total Split (%)	61.4%		14.0%	75.4%	24.6%	24.6%	
Yellow Time (s)	4.0		4.0	4.0	4.5	4.5	
All-Red Time (s)	2.0		2.0	2.0	2.0	2.0	
Lost Time Adjust (s)	0.0		0.0	0.0	0.0	0.0	
Total Lost Time (s)	6.0		6.0	6.0	6.5	6.5	
Lead/Lag	Lag		Lead				
Lead-Lag Optimize?	Yes		Yes				
Recall Mode	C-Max		None	C-Max	Max	Max	
Act Effect Green (s)	64.2	114.0	80.0	80.0	21.5	21.5	114.0
Actuated g/C Ratio	0.56	1.00	0.70	0.70	0.19	0.19	1.00
v/c Ratio	0.21	0.19	0.45	0.17	0.22	0.23	0.03
Control Delay	3.7	0.4	11.6	8.8	41.4	39.9	0.0
Queue Delay	0.0	0.0	0.0	0.0	0.0	0.0	0.0
Total Delay	3.7	0.4	11.6	8.8	41.4	39.9	0.0
LOS	A	A	B	A	D	D	A
Approach Delay	2.3			9.9		31.7	
Approach LOS	A			A		C	

Intersection Summary

Cycle Length: 114
 Actuated Cycle Length: 114
 Offset: 56 (49%), Referenced to phase 4:EBT and 8:WBTL, Start of Green
 Natural Cycle: 60
 Control Type: Actuated-Coordinated
 Maximum v/c Ratio: 0.45
 Intersection Signal Delay: 8.9
 Intersection Capacity Utilization 49.0%
 Analysis Period (min) 15
 Intersection LOS: A
 ICU Level of Service A

Splits and Phases: 4: Powers Blvd SB Ramp & Old Ranch Rd

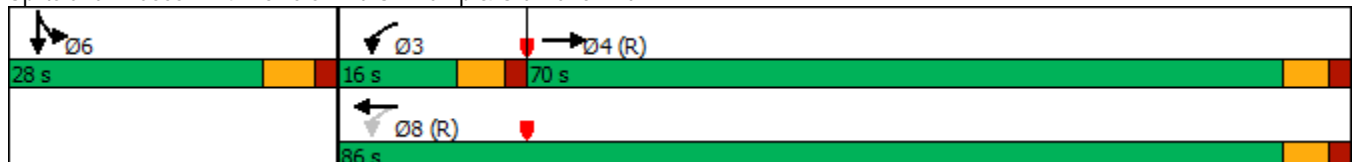

HCM 6th Signalized Intersection Summary
4: Powers Blvd SB Ramp & Old Ranch Rd

2045 Background PM

09/06/2023

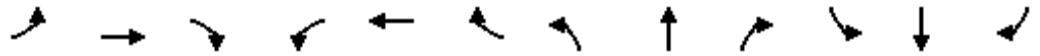

Movement	EBL	EBT	EBR	WBL	WBT	WBR	NBL	NBT	NBR	SBL	SBT	SBR
Lane Configurations		↑↑	↗	↘	↑↑					↖	↕	↗
Traffic Volume (veh/h)	0	411	296	290	411	0	0	0	0	128	3	43
Future Volume (veh/h)	0	411	296	290	411	0	0	0	0	128	3	43
Initial Q (Qb), veh	0	0	0	0	0	0				0	0	0
Ped-Bike Adj(A_pbT)	1.00		1.00	1.00		1.00				1.00		1.00
Parking Bus, Adj	1.00	1.00	1.00	1.00	1.00	1.00				1.00	1.00	1.00
Work Zone On Approach		No			No						No	
Adj Sat Flow, veh/h/ln	0	1870	1870	1870	1870	0				1870	1870	1870
Adj Flow Rate, veh/h	0	428	0	302	428	0				148	0	0
Peak Hour Factor	0.96	0.96	0.96	0.96	0.96	0.96				0.96	0.96	0.96
Percent Heavy Veh, %	0	2	2	2	2	0				2	2	2
Cap, veh/h	0	1995		758	2494	0				672	0	
Arrive On Green	0.00	1.00	0.00	0.18	1.00	0.00				0.19	0.00	0.00
Sat Flow, veh/h	0	3647	1585	1781	3647	0				3563	0	1585
Grp Volume(v), veh/h	0	428	0	302	428	0				148	0	0
Grp Sat Flow(s),veh/h/ln	0	1777	1585	1781	1777	0				1781	0	1585
Q Serve(g_s), s	0.0	0.0	0.0	8.8	0.0	0.0				4.0	0.0	0.0
Cycle Q Clear(g_c), s	0.0	0.0	0.0	8.8	0.0	0.0				4.0	0.0	0.0
Prop In Lane	0.00		1.00	1.00		0.00				1.00		1.00
Lane Grp Cap(c), veh/h	0	1995		758	2494	0				672	0	
V/C Ratio(X)	0.00	0.21		0.40	0.17	0.00				0.22	0.00	
Avail Cap(c_a), veh/h	0	1995		758	2494	0				672	0	
HCM Platoon Ratio	1.00	2.00	2.00	2.00	2.00	1.00				1.00	1.00	1.00
Upstream Filter(l)	0.00	0.95	0.00	0.93	0.93	0.00				1.00	0.00	0.00
Uniform Delay (d), s/veh	0.0	0.0	0.0	7.1	0.0	0.0				39.2	0.0	0.0
Incr Delay (d2), s/veh	0.0	0.2	0.0	0.3	0.1	0.0				0.8	0.0	0.0
Initial Q Delay(d3),s/veh	0.0	0.0	0.0	0.0	0.0	0.0				0.0	0.0	0.0
%ile BackOfQ(50%),veh/ln	0.0	0.1	0.0	2.5	0.0	0.0				1.8	0.0	0.0
Unsig. Movement Delay, s/veh												
LnGrp Delay(d),s/veh	0.0	0.2	0.0	7.4	0.1	0.0				39.9	0.0	0.0
LnGrp LOS	A	A		A	A	A				D	A	
Approach Vol, veh/h		428			730						148	
Approach Delay, s/veh		0.2			3.1						39.9	
Approach LOS		A			A						D	
Timer - Assigned Phs			3	4		6		8				
Phs Duration (G+Y+Rc), s			16.0	70.0		28.0		86.0				
Change Period (Y+Rc), s			6.0	6.0		6.5		6.0				
Max Green Setting (Gmax), s			10.0	64.0		21.5		80.0				
Max Q Clear Time (g_c+I1), s			10.8	2.0		6.0		2.0				
Green Ext Time (p_c), s			0.0	3.2		0.4		3.2				

Intersection Summary

HCM 6th Ctrl Delay	6.4
HCM 6th LOS	A

Notes

User approved volume balancing among the lanes for turning movement.
Unsignalized Delay for [EBR, SBR] is excluded from calculations of the approach delay and intersection delay.

Timings

2045 Total AM

09/06/2023

4: Powers Blvd SB Ramp & Old Ranch Rd

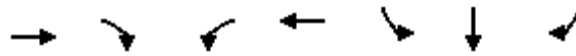

Lane Group	EBT	EBR	WBL	WBT	SBL	SBT	SBR
Lane Configurations	↑↑	↑	↵	↑↑	↵	↕	↵
Traffic Volume (vph)	535	377	436	1046	154	0	73
Future Volume (vph)	535	377	436	1046	154	0	73
Turn Type	NA	Free	pm+pt	NA	Split	NA	Free
Protected Phases	4		3	8	6	6	
Permitted Phases		Free	8				Free
Detector Phase	4		3	8	6	6	
Switch Phase							
Minimum Initial (s)	15.0		4.0	15.0	6.0	6.0	
Minimum Split (s)	24.0		10.0	24.0	21.5	21.5	
Total Split (s)	70.0		22.0	92.0	22.0	22.0	
Total Split (%)	61.4%		19.3%	80.7%	19.3%	19.3%	
Yellow Time (s)	4.0		4.0	4.0	4.5	4.5	
All-Red Time (s)	2.0		2.0	2.0	2.0	2.0	
Lost Time Adjust (s)	0.0		0.0	0.0	0.0	0.0	
Total Lost Time (s)	6.0		6.0	6.0	6.5	6.5	
Lead/Lag	Lag		Lead				
Lead-Lag Optimize?	Yes		Yes				
Recall Mode	C-Max		None	C-Max	Max	Max	
Act Effect Green (s)	64.0	114.0	86.0	86.0	15.5	15.5	114.0
Actuated g/C Ratio	0.56	1.00	0.75	0.75	0.14	0.14	1.00
v/c Ratio	0.35	0.31	0.93	0.51	0.46	0.36	0.06
Control Delay	6.1	0.6	26.8	8.4	52.8	16.9	0.1
Queue Delay	0.0	0.0	0.0	0.6	0.0	0.0	0.0
Total Delay	6.1	0.6	26.8	9.0	52.8	16.9	0.1
LOS	A	A	C	A	D	B	A
Approach Delay	3.9			14.3		24.9	
Approach LOS	A			B		C	

Intersection Summary

Cycle Length: 114
 Actuated Cycle Length: 114
 Offset: 56 (49%), Referenced to phase 4:EBT and 8:WBTL, Start of Green
 Natural Cycle: 75
 Control Type: Actuated-Coordinated
 Maximum v/c Ratio: 0.93
 Intersection Signal Delay: 11.6
 Intersection LOS: B
 Intersection Capacity Utilization 63.3%
 ICU Level of Service B
 Analysis Period (min) 15

Splits and Phases: 4: Powers Blvd SB Ramp & Old Ranch Rd

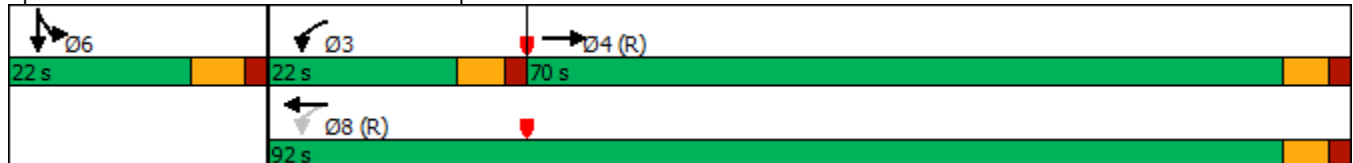

HCM 6th Signalized Intersection Summary
4: Powers Blvd SB Ramp & Old Ranch Rd

2045 Total AM

09/06/2023

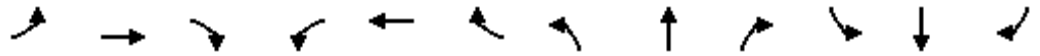

Movement	EBL	EBT	EBR	WBL	WBT	WBR	NBL	NBT	NBR	SBL	SBT	SBR
Lane Configurations		↑↑	↗	↘	↑↑					↘	↕	↗
Traffic Volume (veh/h)	0	535	377	436	1046	0	0	0	0	154	0	73
Future Volume (veh/h)	0	535	377	436	1046	0	0	0	0	154	0	73
Initial Q (Qb), veh	0	0	0	0	0	0				0	0	0
Ped-Bike Adj(A_pbT)	1.00		1.00	1.00		1.00				1.00		1.00
Parking Bus, Adj	1.00	1.00	1.00	1.00	1.00	1.00				1.00	1.00	1.00
Work Zone On Approach		No			No						No	
Adj Sat Flow, veh/h/ln	0	1870	1870	1870	1870	0				1870	1870	1870
Adj Flow Rate, veh/h	0	695	0	566	1358	0				230	0	0
Peak Hour Factor	0.77	0.77	0.77	0.77	0.77	0.77				0.77	0.77	0.77
Percent Heavy Veh, %	0	2	2	2	2	0				2	2	2
Cap, veh/h	0	1995		734	2681	0				484	0	
Arrive On Green	0.00	1.00	0.00	0.14	0.75	0.00				0.14	0.00	0.00
Sat Flow, veh/h	0	3647	1585	1781	3647	0				3563	0	1585
Grp Volume(v), veh/h	0	695	0	566	1358	0				230	0	0
Grp Sat Flow(s),veh/h/ln	0	1777	1585	1781	1777	0				1781	0	1585
Q Serve(g_s), s	0.0	0.0	0.0	14.9	17.3	0.0				6.8	0.0	0.0
Cycle Q Clear(g_c), s	0.0	0.0	0.0	14.9	17.3	0.0				6.8	0.0	0.0
Prop In Lane	0.00		1.00	1.00		0.00				1.00		1.00
Lane Grp Cap(c), veh/h	0	1995		734	2681	0				484	0	
V/C Ratio(X)	0.00	0.35		0.77	0.51	0.00				0.47	0.00	
Avail Cap(c_a), veh/h	0	1995		734	2681	0				484	0	
HCM Platoon Ratio	1.00	2.00	2.00	1.00	1.00	1.00				1.00	1.00	1.00
Upstream Filter(I)	0.00	0.86	0.00	0.45	0.45	0.00				1.00	0.00	0.00
Uniform Delay (d), s/veh	0.0	0.0	0.0	6.7	5.6	0.0				45.5	0.0	0.0
Incr Delay (d2), s/veh	0.0	0.4	0.0	2.3	0.3	0.0				3.3	0.0	0.0
Initial Q Delay(d3),s/veh	0.0	0.0	0.0	0.0	0.0	0.0				0.0	0.0	0.0
%ile BackOfQ(50%),veh/ln	0.0	0.1	0.0	5.4	5.5	0.0				3.2	0.0	0.0
Unsig. Movement Delay, s/veh												
LnGrp Delay(d),s/veh	0.0	0.4	0.0	9.0	5.9	0.0				48.8	0.0	0.0
LnGrp LOS	A	A		A	A	A				D	A	
Approach Vol, veh/h		695			1924						230	
Approach Delay, s/veh		0.4			6.8						48.8	
Approach LOS		A			A						D	
Timer - Assigned Phs			3	4		6		8				
Phs Duration (G+Y+Rc), s			22.0	70.0		22.0		92.0				
Change Period (Y+Rc), s			6.0	6.0		6.5		6.0				
Max Green Setting (Gmax), s			16.0	64.0		15.5		86.0				
Max Q Clear Time (g_c+I1), s			16.9	2.0		8.8		19.3				
Green Ext Time (p_c), s			0.0	5.8		0.4		16.0				
Intersection Summary												
HCM 6th Ctrl Delay			8.6									
HCM 6th LOS			A									
Notes												
User approved volume balancing among the lanes for turning movement.												
Unsignalized Delay for [EBR, SBR] is excluded from calculations of the approach delay and intersection delay.												

Timings

2045 Total PM

09/06/2023

4: Powers Blvd SB Ramp & Old Ranch Rd

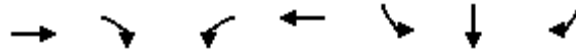

Lane Group	EBT	EBR	WBL	WBT	SBL	SBT	SBR
Lane Configurations	↑↑	↑	↵	↑↑	↵	↕	↵
Traffic Volume (vph)	429	327	290	474	128	3	64
Future Volume (vph)	429	327	290	474	128	3	64
Turn Type	NA	Free	pm+pt	NA	Split	NA	Free
Protected Phases	4		3	8	6	6	
Permitted Phases		Free	8				Free
Detector Phase	4		3	8	6	6	
Switch Phase							
Minimum Initial (s)	15.0		4.0	15.0	6.0	6.0	
Minimum Split (s)	24.0		10.0	24.0	24.5	24.5	
Total Split (s)	70.0		16.0	86.0	28.0	28.0	
Total Split (%)	61.4%		14.0%	75.4%	24.6%	24.6%	
Yellow Time (s)	4.0		4.0	4.0	4.5	4.5	
All-Red Time (s)	2.0		2.0	2.0	2.0	2.0	
Lost Time Adjust (s)	0.0		0.0	0.0	0.0	0.0	
Total Lost Time (s)	6.0		6.0	6.0	6.5	6.5	
Lead/Lag	Lag		Lead				
Lead-Lag Optimize?	Yes		Yes				
Recall Mode	C-Max		None	C-Max	Max	Max	
Act Effect Green (s)	64.2	114.0	80.0	80.0	21.5	21.5	114.0
Actuated g/C Ratio	0.56	1.00	0.70	0.70	0.19	0.19	1.00
v/c Ratio	0.22	0.22	0.46	0.20	0.23	0.23	0.04
Control Delay	4.0	0.5	11.1	8.3	41.5	39.4	0.1
Queue Delay	0.0	0.0	0.0	0.0	0.0	0.0	0.0
Total Delay	4.0	0.5	11.1	8.3	41.5	39.4	0.1
LOS	A	A	B	A	D	D	A
Approach Delay	2.5			9.4		28.5	
Approach LOS	A			A		C	

Intersection Summary

Cycle Length: 114
 Actuated Cycle Length: 114
 Offset: 56 (49%), Referenced to phase 4:EBT and 8:WBTL, Start of Green
 Natural Cycle: 60
 Control Type: Actuated-Coordinated
 Maximum v/c Ratio: 0.46
 Intersection Signal Delay: 8.5
 Intersection LOS: A
 Intersection Capacity Utilization 49.0%
 ICU Level of Service A
 Analysis Period (min) 15

Splits and Phases: 4: Powers Blvd SB Ramp & Old Ranch Rd

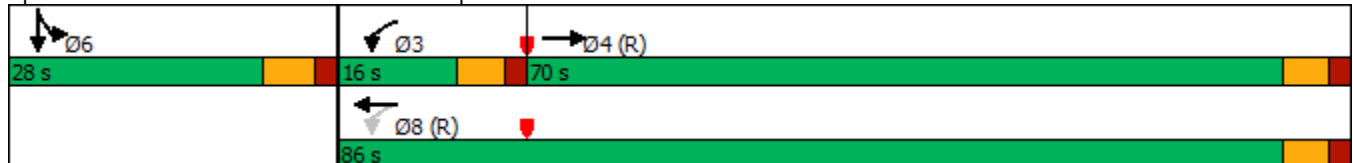

HCM 6th Signalized Intersection Summary
 4: Powers Blvd SB Ramp & Old Ranch Rd

2045 Total PM
 09/06/2023



Movement	EBL	EBT	EBR	WBL	WBT	WBR	NBL	NBT	NBR	SBL	SBT	SBR
Lane Configurations		↑↑	↗	↘	↑↑					↘	↕	↗
Traffic Volume (veh/h)	0	429	327	290	474	0	0	0	0	128	3	64
Future Volume (veh/h)	0	429	327	290	474	0	0	0	0	128	3	64
Initial Q (Qb), veh	0	0	0	0	0	0				0	0	0
Ped-Bike Adj(A_pbT)	1.00		1.00	1.00		1.00				1.00		1.00
Parking Bus, Adj	1.00	1.00	1.00	1.00	1.00	1.00				1.00	1.00	1.00
Work Zone On Approach		No			No						No	
Adj Sat Flow, veh/h/ln	0	1870	1870	1870	1870	0				1870	1870	1870
Adj Flow Rate, veh/h	0	447	0	302	494	0				155	0	0
Peak Hour Factor	0.96	0.96	0.96	0.96	0.96	0.96				0.96	0.96	0.96
Percent Heavy Veh, %	0	2	2	2	2	0				2	2	2
Cap, veh/h	0	1995		749	2494	0				672	0	
Arrive On Green	0.00	1.00	0.00	0.18	1.00	0.00				0.19	0.00	0.00
Sat Flow, veh/h	0	3647	1585	1781	3647	0				3563	0	1585
Grp Volume(v), veh/h	0	447	0	302	494	0				155	0	0
Grp Sat Flow(s),veh/h/ln	0	1777	1585	1781	1777	0				1781	0	1585
Q Serve(g_s), s	0.0	0.0	0.0	8.8	0.0	0.0				4.2	0.0	0.0
Cycle Q Clear(g_c), s	0.0	0.0	0.0	8.8	0.0	0.0				4.2	0.0	0.0
Prop In Lane	0.00		1.00	1.00		0.00				1.00		1.00
Lane Grp Cap(c), veh/h	0	1995		749	2494	0				672	0	
V/C Ratio(X)	0.00	0.22		0.40	0.20	0.00				0.23	0.00	
Avail Cap(c_a), veh/h	0	1995		749	2494	0				672	0	
HCM Platoon Ratio	1.00	2.00	2.00	2.00	2.00	1.00				1.00	1.00	1.00
Upstream Filter(l)	0.00	0.95	0.00	0.91	0.91	0.00				1.00	0.00	0.00
Uniform Delay (d), s/veh	0.0	0.0	0.0	7.1	0.0	0.0				39.2	0.0	0.0
Incr Delay (d2), s/veh	0.0	0.2	0.0	0.3	0.2	0.0				0.8	0.0	0.0
Initial Q Delay(d3),s/veh	0.0	0.0	0.0	0.0	0.0	0.0				0.0	0.0	0.0
%ile BackOfQ(50%),veh/ln	0.0	0.1	0.0	2.5	0.1	0.0				1.9	0.0	0.0
Unsig. Movement Delay, s/veh												
LnGrp Delay(d),s/veh	0.0	0.2	0.0	7.4	0.2	0.0				40.0	0.0	0.0
LnGrp LOS	A	A		A	A	A				D	A	
Approach Vol, veh/h		447			796						155	
Approach Delay, s/veh		0.2			2.9						40.0	
Approach LOS		A			A						D	
Timer - Assigned Phs			3	4		6		8				
Phs Duration (G+Y+Rc), s			16.0	70.0		28.0		86.0				
Change Period (Y+Rc), s			6.0	6.0		6.5		6.0				
Max Green Setting (Gmax), s			10.0	64.0		21.5		80.0				
Max Q Clear Time (g_c+I1), s			10.8	2.0		6.2		2.0				
Green Ext Time (p_c), s			0.0	3.4		0.4		3.8				
Intersection Summary												
HCM 6th Ctrl Delay			6.2									
HCM 6th LOS			A									
Notes												
User approved volume balancing among the lanes for turning movement.												
Unsignalized Delay for [EBR, SBR] is excluded from calculations of the approach delay and intersection delay.												

Timings
5: Powers Blvd NB Ramp & Old Ranch Rd

2023 Existing AM
09/06/2023



Lane Group	EBL	EBT	WBT	WBR	NBL	NBT	NBR
Lane Configurations	↶	↷	↷	↷	↶	↷	↷
Traffic Volume (vph)	36	447	775	134	249	0	307
Future Volume (vph)	36	447	775	134	249	0	307
Turn Type	pm+pt	NA	NA	Free	Split	NA	Free
Protected Phases	7	4	8		2	2	
Permitted Phases	4			Free			Free
Detector Phase	7	4	8		2	2	
Switch Phase							
Minimum Initial (s)	4.0	12.0	12.0		6.0	6.0	
Minimum Split (s)	10.0	24.0	24.0		20.0	20.0	
Total Split (s)	18.0	94.0	76.0		20.0	20.0	
Total Split (%)	15.8%	82.5%	66.7%		17.5%	17.5%	
Yellow Time (s)	4.0	4.0	4.0		4.5	4.5	
All-Red Time (s)	2.0	2.0	2.0		2.0	2.0	
Lost Time Adjust (s)	0.0	0.0	0.0		0.0	0.0	
Total Lost Time (s)	6.0	6.0	6.0		6.5	6.5	
Lead/Lag	Lead		Lag				
Lead-Lag Optimize?	Yes		Yes				
Recall Mode	None	C-Max	C-Max		Max	Max	
Act Effct Green (s)	88.0	88.0	78.1	114.0	13.5	13.5	114.0
Actuated g/C Ratio	0.77	0.77	0.69	1.00	0.12	0.12	1.00
v/c Ratio	0.12	0.21	0.42	0.11	1.27	0.95	0.15
Control Delay	8.3	10.9	9.0	0.1	194.9	77.6	0.2
Queue Delay	0.0	0.0	0.0	0.0	0.0	0.0	0.0
Total Delay	8.3	10.9	9.0	0.1	194.9	77.6	0.2
LOS	A	B	A	A	F	E	A
Approach Delay		10.7	7.7			93.8	
Approach LOS		B	A			F	

Intersection Summary

Cycle Length: 114
 Actuated Cycle Length: 114
 Offset: 2 (2%), Referenced to phase 4:EBTL and 8:WBT, Start of Green
 Natural Cycle: 60
 Control Type: Actuated-Coordinated
 Maximum v/c Ratio: 1.27
 Intersection Signal Delay: 33.0
 Intersection LOS: C
 Intersection Capacity Utilization 50.3%
 ICU Level of Service A
 Analysis Period (min) 15

Splits and Phases: 5: Powers Blvd NB Ramp & Old Ranch Rd



HCM 6th Signalized Intersection Summary
5: Powers Blvd NB Ramp & Old Ranch Rd

2023 Existing AM
09/06/2023



Movement	EBL	EBT	EBR	WBL	WBT	WBR	NBL	NBT	NBR	SBL	SBT	SBR
Lane Configurations	↘	↑↑			↑↑	↗	↘	↕	↗			
Traffic Volume (veh/h)	36	447	0	0	775	134	249	0	307	0	0	0
Future Volume (veh/h)	36	447	0	0	775	134	249	0	307	0	0	0
Initial Q (Qb), veh	0	0	0	0	0	0	0	0	0			
Ped-Bike Adj(A_pbT)	1.00		1.00	1.00		1.00	1.00		1.00			
Parking Bus, Adj	1.00	1.00	1.00	1.00	1.00	1.00	1.00	1.00	1.00			
Work Zone On Approach		No			No			No				
Adj Sat Flow, veh/h/ln	1870	1870	0	0	1870	1870	1870	1870	1870			
Adj Flow Rate, veh/h	47	581	0	0	1006	0	459	0	0			
Peak Hour Factor	0.77	0.77	0.77	0.77	0.77	0.77	0.77	0.77	0.77			
Percent Heavy Veh, %	2	2	0	0	2	2	2	2	2			
Cap, veh/h	431	2743	0	0	2460		422	0				
Arrive On Green	0.03	0.77	0.00	0.00	0.69	0.00	0.12	0.00	0.00			
Sat Flow, veh/h	1781	3647	0	0	3647	1585	3563	0	1585			
Grp Volume(v), veh/h	47	581	0	0	1006	0	459	0	0			
Grp Sat Flow(s),veh/h/ln	1781	1777	0	0	1777	1585	1781	0	1585			
Q Serve(g_s), s	0.8	5.1	0.0	0.0	13.9	0.0	13.5	0.0	0.0			
Cycle Q Clear(g_c), s	0.8	5.1	0.0	0.0	13.9	0.0	13.5	0.0	0.0			
Prop In Lane	1.00		0.00	0.00		1.00	1.00		1.00			
Lane Grp Cap(c), veh/h	431	2743	0	0	2460		422	0				
V/C Ratio(X)	0.11	0.21	0.00	0.00	0.41		1.09	0.00				
Avail Cap(c_a), veh/h	570	2743	0	0	2460		422	0				
HCM Platoon Ratio	1.00	1.00	1.00	1.00	1.00	1.00	1.00	1.00	1.00			
Upstream Filter(I)	0.98	0.98	0.00	0.00	1.00	0.00	1.00	0.00	0.00			
Uniform Delay (d), s/veh	5.3	3.5	0.0	0.0	7.5	0.0	50.3	0.0	0.0			
Incr Delay (d2), s/veh	0.1	0.2	0.0	0.0	0.5	0.0	69.6	0.0	0.0			
Initial Q Delay(d3),s/veh	0.0	0.0	0.0	0.0	0.0	0.0	0.0	0.0	0.0			
%ile BackOfQ(50%),veh/ln	0.3	1.6	0.0	0.0	5.0	0.0	10.1	0.0	0.0			
Unsig. Movement Delay, s/veh												
LnGrp Delay(d),s/veh	5.4	3.7	0.0	0.0	8.0	0.0	119.8	0.0	0.0			
LnGrp LOS	A	A	A	A	A		F	A				
Approach Vol, veh/h		628			1006			459				
Approach Delay, s/veh		3.8			8.0			119.8				
Approach LOS		A			A			F				
Timer - Assigned Phs		2		4			7	8				
Phs Duration (G+Y+Rc), s		20.0		94.0			9.1	84.9				
Change Period (Y+Rc), s		6.5		6.0			6.0	6.0				
Max Green Setting (Gmax), s		13.5		88.0			12.0	70.0				
Max Q Clear Time (g_c+I1), s		15.5		7.1			2.8	15.9				
Green Ext Time (p_c), s		0.0		4.6			0.0	9.5				

Intersection Summary

HCM 6th Ctrl Delay	31.3
HCM 6th LOS	C

Notes

User approved volume balancing among the lanes for turning movement.
Unsignalized Delay for [NBR, WBR] is excluded from calculations of the approach delay and intersection delay.

Timings
5: Powers Blvd NB Ramp & Old Ranch Rd

2023 Existing PM
09/06/2023



Lane Group	EBL	EBT	WBT	WBR	NBL	NBT	NBR
Lane Configurations	↶	↷	↷	↷	↶	↷	↷
Traffic Volume (vph)	31	382	333	105	139	2	215
Future Volume (vph)	31	382	333	105	139	2	215
Turn Type	pm+pt	NA	NA	Free	Split	NA	Free
Protected Phases	7	4	8		2	2	
Permitted Phases	4			Free			Free
Detector Phase	7	4	8		2	2	
Switch Phase							
Minimum Initial (s)	4.0	12.0	12.0		6.0	6.0	
Minimum Split (s)	10.0	24.0	24.0		20.0	20.0	
Total Split (s)	18.0	94.0	76.0		20.0	20.0	
Total Split (%)	15.8%	82.5%	66.7%		17.5%	17.5%	
Yellow Time (s)	4.0	4.0	4.0		4.5	4.5	
All-Red Time (s)	2.0	2.0	2.0		2.0	2.0	
Lost Time Adjust (s)	0.0	0.0	0.0		0.0	0.0	
Total Lost Time (s)	6.0	6.0	6.0		6.5	6.5	
Lead/Lag	Lead		Lag				
Lead-Lag Optimize?	Yes		Yes				
Recall Mode	None	C-Max	C-Max		Max	Max	
Act Effect Green (s)	88.0	88.0	80.7	114.0	13.5	13.5	114.0
Actuated g/C Ratio	0.77	0.77	0.71	1.00	0.12	0.12	1.00
v/c Ratio	0.04	0.14	0.14	0.07	0.63	0.45	0.08
Control Delay	5.8	7.6	6.2	0.1	63.1	18.5	0.1
Queue Delay	0.0	0.0	0.0	0.0	0.0	0.0	0.0
Total Delay	5.8	7.6	6.2	0.1	63.1	18.5	0.1
LOS	A	A	A	A	E	B	A
Approach Delay		7.5	4.7			28.0	
Approach LOS		A	A			C	

Intersection Summary

Cycle Length: 114
 Actuated Cycle Length: 114
 Offset: 2 (2%), Referenced to phase 4:EBTL and 8:WBT, Start of Green
 Natural Cycle: 55
 Control Type: Actuated-Coordinated
 Maximum v/c Ratio: 0.63
 Intersection Signal Delay: 12.5
 Intersection LOS: B
 Intersection Capacity Utilization 44.5%
 ICU Level of Service A
 Analysis Period (min) 15

Splits and Phases: 5: Powers Blvd NB Ramp & Old Ranch Rd

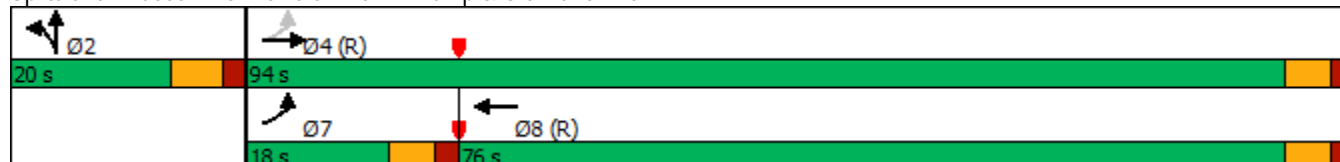

HCM 6th Signalized Intersection Summary
5: Powers Blvd NB Ramp & Old Ranch Rd

2023 Existing PM
09/06/2023



Movement	EBL	EBT	EBR	WBL	WBT	WBR	NBL	NBT	NBR	SBL	SBT	SBR
Lane Configurations	↘	↑↑			↑↑	↗	↘	↕	↗			
Traffic Volume (veh/h)	31	382	0	0	333	105	139	2	215	0	0	0
Future Volume (veh/h)	31	382	0	0	333	105	139	2	215	0	0	0
Initial Q (Qb), veh	0	0	0	0	0	0	0	0	0			
Ped-Bike Adj(A_pbT)	1.00		1.00	1.00		1.00	1.00		1.00			
Parking Bus, Adj	1.00	1.00	1.00	1.00	1.00	1.00	1.00	1.00	1.00			
Work Zone On Approach		No			No			No				
Adj Sat Flow, veh/h/ln	1870	1870	0	0	1870	1870	1870	1870	1870			
Adj Flow Rate, veh/h	32	390	0	0	340	0	95	0	0			
Peak Hour Factor	0.98	0.98	0.98	0.98	0.98	0.98	0.98	0.98	0.98			
Percent Heavy Veh, %	2	2	0	0	2	2	2	2	2			
Cap, veh/h	795	2743	0	0	2477		211	0				
Arrive On Green	0.02	0.77	0.00	0.00	0.70	0.00	0.12	0.00	0.00			
Sat Flow, veh/h	1781	3647	0	0	3647	1585	1781	0	3170			
Grp Volume(v), veh/h	32	390	0	0	340	0	95	0	0			
Grp Sat Flow(s),veh/h/ln	1781	1777	0	0	1777	1585	1781	0	1585			
Q Serve(g_s), s	0.5	3.2	0.0	0.0	3.7	0.0	5.7	0.0	0.0			
Cycle Q Clear(g_c), s	0.5	3.2	0.0	0.0	3.7	0.0	5.7	0.0	0.0			
Prop In Lane	1.00		0.00	0.00		1.00	1.00		1.00			
Lane Grp Cap(c), veh/h	795	2743	0	0	2477		211	0				
V/C Ratio(X)	0.04	0.14	0.00	0.00	0.14		0.45	0.00				
Avail Cap(c_a), veh/h	942	2743	0	0	2477		211	0				
HCM Platoon Ratio	1.00	1.00	1.00	1.00	1.00	1.00	1.00	1.00	1.00			
Upstream Filter(I)	0.99	0.99	0.00	0.00	1.00	0.00	1.00	0.00	0.00			
Uniform Delay (d), s/veh	4.2	3.3	0.0	0.0	5.8	0.0	46.8	0.0	0.0			
Incr Delay (d2), s/veh	0.0	0.1	0.0	0.0	0.1	0.0	6.8	0.0	0.0			
Initial Q Delay(d3),s/veh	0.0	0.0	0.0	0.0	0.0	0.0	0.0	0.0	0.0			
%ile BackOfQ(50%),veh/ln	0.2	1.0	0.0	0.0	1.3	0.0	2.9	0.0	0.0			
Unsig. Movement Delay, s/veh												
LnGrp Delay(d),s/veh	4.2	3.4	0.0	0.0	5.9	0.0	53.6	0.0	0.0			
LnGrp LOS	A	A	A	A	A		D	A				
Approach Vol, veh/h		422			340			95				
Approach Delay, s/veh		3.5			5.9			53.6				
Approach LOS		A			A			D				
Timer - Assigned Phs		2		4			7	8				
Phs Duration (G+Y+Rc), s		20.0		94.0			8.5	85.5				
Change Period (Y+Rc), s		6.5		6.0			6.0	6.0				
Max Green Setting (Gmax), s		13.5		88.0			12.0	70.0				
Max Q Clear Time (g_c+I1), s		7.7		5.2			2.5	5.7				
Green Ext Time (p_c), s		0.1		2.9			0.0	2.5				

Intersection Summary

HCM 6th Ctrl Delay	10.0
HCM 6th LOS	B

Notes

User approved volume balancing among the lanes for turning movement.
Unsignalized Delay for [NBR, WBR] is excluded from calculations of the approach delay and intersection delay.

Timings
5: Powers Blvd NB Ramp & Old Ranch Rd



Lane Group	EBL	EBT	WBT	WBR	NBL	NBT	NBR
Lane Configurations							
Traffic Volume (vph)	37	461	798	138	257	0	316
Future Volume (vph)	37	461	798	138	257	0	316
Turn Type	pm+pt	NA	NA	Free	Split	NA	Free
Protected Phases	7	4	8		2	2	
Permitted Phases	4			Free			Free
Detector Phase	7	4	8		2	2	
Switch Phase							
Minimum Initial (s)	4.0	12.0	12.0		6.0	6.0	
Minimum Split (s)	10.0	24.0	24.0		20.0	20.0	
Total Split (s)	18.0	94.0	76.0		20.0	20.0	
Total Split (%)	15.8%	82.5%	66.7%		17.5%	17.5%	
Yellow Time (s)	4.0	4.0	4.0		4.5	4.5	
All-Red Time (s)	2.0	2.0	2.0		2.0	2.0	
Lost Time Adjust (s)	0.0	0.0	0.0		0.0	0.0	
Total Lost Time (s)	6.0	6.0	6.0		6.5	6.5	
Lead/Lag	Lead		Lag				
Lead-Lag Optimize?	Yes		Yes				
Recall Mode	None	C-Max	C-Max		Max	Max	
Act Effect Green (s)	88.0	88.0	78.1	114.0	13.5	13.5	114.0
Actuated g/C Ratio	0.77	0.77	0.69	1.00	0.12	0.12	1.00
v/c Ratio	0.12	0.22	0.43	0.11	1.31	0.97	0.16
Control Delay	8.3	10.9	9.1	0.1	211.6	83.3	0.2
Queue Delay	0.0	0.0	0.0	0.0	0.0	0.0	0.0
Total Delay	8.3	10.9	9.1	0.1	211.6	83.3	0.2
LOS	A	B	A	A	F	F	A
Approach Delay		10.7	7.8			101.7	
Approach LOS		B	A			F	

Intersection Summary

Cycle Length: 114
 Actuated Cycle Length: 114
 Offset: 2 (2%), Referenced to phase 4:EBTL and 8:WBT, Start of Green
 Natural Cycle: 60
 Control Type: Actuated-Coordinated
 Maximum v/c Ratio: 1.31
 Intersection Signal Delay: 35.4
 Intersection LOS: D
 Intersection Capacity Utilization 51.1%
 ICU Level of Service A
 Analysis Period (min) 15

Splits and Phases: 5: Powers Blvd NB Ramp & Old Ranch Rd

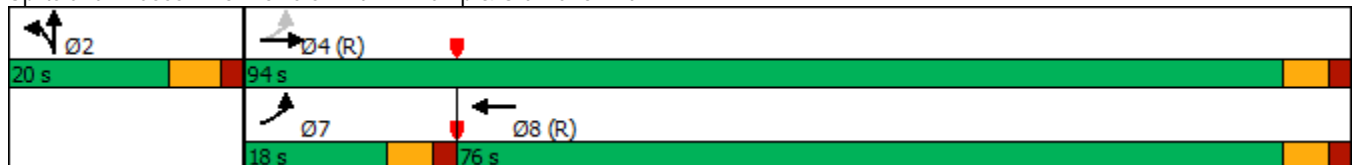

HCM 6th Signalized Intersection Summary
5: Powers Blvd NB Ramp & Old Ranch Rd

2025 Background AM
09/06/2023



Movement	EBL	EBT	EBR	WBL	WBT	WBR	NBL	NBT	NBR	SBL	SBT	SBR
Lane Configurations	↖	↗			↖	↗	↖	↕	↗			
Traffic Volume (veh/h)	37	461	0	0	798	138	257	0	316	0	0	0
Future Volume (veh/h)	37	461	0	0	798	138	257	0	316	0	0	0
Initial Q (Qb), veh	0	0	0	0	0	0	0	0	0			
Ped-Bike Adj(A_pbT)	1.00		1.00	1.00		1.00	1.00		1.00			
Parking Bus, Adj	1.00	1.00	1.00	1.00	1.00	1.00	1.00	1.00	1.00			
Work Zone On Approach		No			No			No				
Adj Sat Flow, veh/h/ln	1870	1870	0	0	1870	1870	1870	1870	1870			
Adj Flow Rate, veh/h	48	599	0	0	1036	0	473	0	0			
Peak Hour Factor	0.77	0.77	0.77	0.77	0.77	0.77	0.77	0.77	0.77			
Percent Heavy Veh, %	2	2	0	0	2	2	2	2	2			
Cap, veh/h	420	2743	0	0	2459		422	0				
Arrive On Green	0.03	0.77	0.00	0.00	0.69	0.00	0.12	0.00	0.00			
Sat Flow, veh/h	1781	3647	0	0	3647	1585	3563	0	1585			
Grp Volume(v), veh/h	48	599	0	0	1036	0	473	0	0			
Grp Sat Flow(s),veh/h/ln	1781	1777	0	0	1777	1585	1781	0	1585			
Q Serve(g_s), s	0.8	5.3	0.0	0.0	14.5	0.0	13.5	0.0	0.0			
Cycle Q Clear(g_c), s	0.8	5.3	0.0	0.0	14.5	0.0	13.5	0.0	0.0			
Prop In Lane	1.00		0.00	0.00		1.00	1.00		1.00			
Lane Grp Cap(c), veh/h	420	2743	0	0	2459		422	0				
V/C Ratio(X)	0.11	0.22	0.00	0.00	0.42		1.12	0.00				
Avail Cap(c_a), veh/h	558	2743	0	0	2459		422	0				
HCM Platoon Ratio	1.00	1.00	1.00	1.00	1.00	1.00	1.00	1.00	1.00			
Upstream Filter(I)	0.98	0.98	0.00	0.00	1.00	0.00	1.00	0.00	0.00			
Uniform Delay (d), s/veh	5.4	3.6	0.0	0.0	7.6	0.0	50.3	0.0	0.0			
Incr Delay (d2), s/veh	0.1	0.2	0.0	0.0	0.5	0.0	81.1	0.0	0.0			
Initial Q Delay(d3),s/veh	0.0	0.0	0.0	0.0	0.0	0.0	0.0	0.0	0.0			
%ile BackOfQ(50%),veh/ln	0.3	1.6	0.0	0.0	5.2	0.0	10.7	0.0	0.0			
Unsig. Movement Delay, s/veh												
LnGrp Delay(d),s/veh	5.5	3.7	0.0	0.0	8.2	0.0	131.3	0.0	0.0			
LnGrp LOS	A	A	A	A	A		F	A				
Approach Vol, veh/h		647			1036			473				
Approach Delay, s/veh		3.9			8.2			131.3				
Approach LOS		A			A			F				
Timer - Assigned Phs		2		4			7	8				
Phs Duration (G+Y+Rc), s		20.0		94.0			9.1	84.9				
Change Period (Y+Rc), s		6.5		6.0			6.0	6.0				
Max Green Setting (Gmax), s		13.5		88.0			12.0	70.0				
Max Q Clear Time (g_c+I1), s		15.5		7.3			2.8	16.5				
Green Ext Time (p_c), s		0.0		4.8			0.0	10.0				

Intersection Summary

HCM 6th Ctrl Delay	33.9
HCM 6th LOS	C

Notes

User approved volume balancing among the lanes for turning movement.
Unsignalized Delay for [NBR, WBR] is excluded from calculations of the approach delay and intersection delay.

Timings
5: Powers Blvd NB Ramp & Old Ranch Rd



Lane Group	EBL	EBT	WBT	WBR	NBL	NBT	NBR
Lane Configurations	↶	↷	↷	↷	↶	↷	↷
Traffic Volume (vph)	32	394	343	108	143	2	221
Future Volume (vph)	32	394	343	108	143	2	221
Turn Type	pm+pt	NA	NA	Free	Split	NA	Free
Protected Phases	7	4	8		2	2	
Permitted Phases	4			Free			Free
Detector Phase	7	4	8		2	2	
Switch Phase							
Minimum Initial (s)	4.0	12.0	12.0		6.0	6.0	
Minimum Split (s)	10.0	24.0	24.0		20.0	20.0	
Total Split (s)	18.0	94.0	76.0		20.0	20.0	
Total Split (%)	15.8%	82.5%	66.7%		17.5%	17.5%	
Yellow Time (s)	4.0	4.0	4.0		4.5	4.5	
All-Red Time (s)	2.0	2.0	2.0		2.0	2.0	
Lost Time Adjust (s)	0.0	0.0	0.0		0.0	0.0	
Total Lost Time (s)	6.0	6.0	6.0		6.5	6.5	
Lead/Lag	Lead		Lag				
Lead-Lag Optimize?	Yes		Yes				
Recall Mode	None	C-Max	C-Max		Max	Max	
Act Effect Green (s)	88.0	88.0	80.7	114.0	13.5	13.5	114.0
Actuated g/C Ratio	0.77	0.77	0.71	1.00	0.12	0.12	1.00
v/c Ratio	0.04	0.15	0.14	0.07	0.65	0.46	0.08
Control Delay	5.8	7.7	6.2	0.1	64.4	18.5	0.1
Queue Delay	0.0	0.0	0.0	0.0	0.0	0.0	0.0
Total Delay	5.8	7.7	6.2	0.1	64.4	18.5	0.1
LOS	A	A	A	A	E	B	A
Approach Delay		7.5	4.7			28.4	
Approach LOS		A	A			C	

Intersection Summary

Cycle Length: 114
 Actuated Cycle Length: 114
 Offset: 2 (2%), Referenced to phase 4:EBTL and 8:WBT, Start of Green
 Natural Cycle: 55
 Control Type: Actuated-Coordinated
 Maximum v/c Ratio: 0.65
 Intersection Signal Delay: 12.7
 Intersection LOS: B
 Intersection Capacity Utilization 44.8%
 ICU Level of Service A
 Analysis Period (min) 15

Splits and Phases: 5: Powers Blvd NB Ramp & Old Ranch Rd

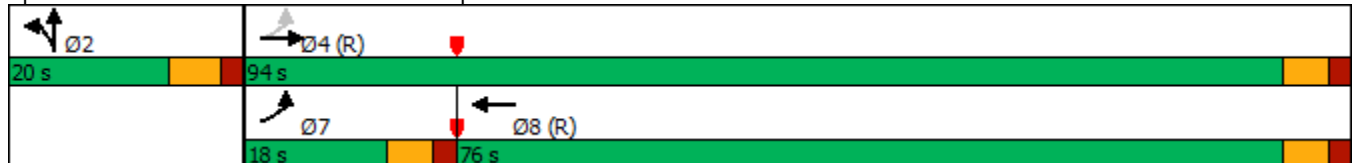

HCM 6th Signalized Intersection Summary
5: Powers Blvd NB Ramp & Old Ranch Rd

2025 Background PM
09/06/2023



Movement	EBL	EBT	EBR	WBL	WBT	WBR	NBL	NBT	NBR	SBL	SBT	SBR
Lane Configurations	↶	↷			↷	↶	↶	↷	↶			
Traffic Volume (veh/h)	32	394	0	0	343	108	143	2	221	0	0	0
Future Volume (veh/h)	32	394	0	0	343	108	143	2	221	0	0	0
Initial Q (Qb), veh	0	0	0	0	0	0	0	0	0			
Ped-Bike Adj(A_pbT)	1.00		1.00	1.00		1.00	1.00		1.00			
Parking Bus, Adj	1.00	1.00	1.00	1.00	1.00	1.00	1.00	1.00	1.00			
Work Zone On Approach		No			No			No				
Adj Sat Flow, veh/h/ln	1870	1870	0	0	1870	1870	1870	1870	1870			
Adj Flow Rate, veh/h	33	402	0	0	350	0	98	0	0			
Peak Hour Factor	0.98	0.98	0.98	0.98	0.98	0.98	0.98	0.98	0.98			
Percent Heavy Veh, %	2	2	0	0	2	2	2	2	2			
Cap, veh/h	788	2743	0	0	2475		211	0				
Arrive On Green	0.02	0.77	0.00	0.00	0.70	0.00	0.12	0.00	0.00			
Sat Flow, veh/h	1781	3647	0	0	3647	1585	1781	0	3170			
Grp Volume(v), veh/h	33	402	0	0	350	0	98	0	0			
Grp Sat Flow(s),veh/h/ln	1781	1777	0	0	1777	1585	1781	0	1585			
Q Serve(g_s), s	0.6	3.3	0.0	0.0	3.8	0.0	5.9	0.0	0.0			
Cycle Q Clear(g_c), s	0.6	3.3	0.0	0.0	3.8	0.0	5.9	0.0	0.0			
Prop In Lane	1.00		0.00	0.00		1.00	1.00		1.00			
Lane Grp Cap(c), veh/h	788	2743	0	0	2475		211	0				
V/C Ratio(X)	0.04	0.15	0.00	0.00	0.14		0.46	0.00				
Avail Cap(c_a), veh/h	935	2743	0	0	2475		211	0				
HCM Platoon Ratio	1.00	1.00	1.00	1.00	1.00	1.00	1.00	1.00	1.00			
Upstream Filter(l)	0.99	0.99	0.00	0.00	1.00	0.00	1.00	0.00	0.00			
Uniform Delay (d), s/veh	4.2	3.3	0.0	0.0	5.8	0.0	46.9	0.0	0.0			
Incr Delay (d2), s/veh	0.0	0.1	0.0	0.0	0.1	0.0	7.2	0.0	0.0			
Initial Q Delay(d3),s/veh	0.0	0.0	0.0	0.0	0.0	0.0	0.0	0.0	0.0			
%ile BackOfQ(50%),veh/ln	0.2	1.0	0.0	0.0	1.3	0.0	3.0	0.0	0.0			
Unsig. Movement Delay, s/veh												
LnGrp Delay(d),s/veh	4.2	3.5	0.0	0.0	5.9	0.0	54.1	0.0	0.0			
LnGrp LOS	A	A	A	A	A		D	A				
Approach Vol, veh/h		435			350			98				
Approach Delay, s/veh		3.5			5.9			54.1				
Approach LOS		A			A			D				
Timer - Assigned Phs		2		4			7	8				
Phs Duration (G+Y+Rc), s		20.0		94.0			8.6	85.4				
Change Period (Y+Rc), s		6.5		6.0			6.0	6.0				
Max Green Setting (Gmax), s		13.5		88.0			12.0	70.0				
Max Q Clear Time (g_c+I1), s		7.9		5.3			2.6	5.8				
Green Ext Time (p_c), s		0.1		3.0			0.0	2.6				

Intersection Summary

HCM 6th Ctrl Delay	10.1
HCM 6th LOS	B

Notes

User approved volume balancing among the lanes for turning movement.
Unsignalized Delay for [NBR, WBR] is excluded from calculations of the approach delay and intersection delay.

Timings

2025 Total AM

5: Powers Blvd NB Ramp & Old Ranch Rd

09/06/2023



Lane Group	EBL	EBT	WBT	WBR	NBL	NBT	NBR
Lane Configurations	↶	↷	↷	↷	↶	↷	↷
Traffic Volume (vph)	55	470	801	138	273	0	316
Future Volume (vph)	55	470	801	138	273	0	316
Turn Type	pm+pt	NA	NA	Free	Split	NA	Free
Protected Phases	7	4	8		2	2	
Permitted Phases	4			Free			Free
Detector Phase	7	4	8		2	2	
Switch Phase							
Minimum Initial (s)	4.0	12.0	12.0		6.0	6.0	
Minimum Split (s)	10.0	24.0	24.0		20.0	20.0	
Total Split (s)	18.0	94.0	76.0		20.0	20.0	
Total Split (%)	15.8%	82.5%	66.7%		17.5%	17.5%	
Yellow Time (s)	4.0	4.0	4.0		4.5	4.5	
All-Red Time (s)	2.0	2.0	2.0		2.0	2.0	
Lost Time Adjust (s)	0.0	0.0	0.0		0.0	0.0	
Total Lost Time (s)	6.0	6.0	6.0		6.5	6.5	
Lead/Lag	Lead		Lag				
Lead-Lag Optimize?	Yes		Yes				
Recall Mode	None	C-Max	C-Max		Max	Max	
Act Effct Green (s)	88.0	88.0	77.8	114.0	13.5	13.5	114.0
Actuated g/C Ratio	0.77	0.77	0.68	1.00	0.12	0.12	1.00
v/c Ratio	0.18	0.22	0.43	0.11	1.34	1.00	0.16
Control Delay	10.1	12.3	9.3	0.1	221.0	89.5	0.2
Queue Delay	0.0	0.0	0.0	0.0	0.0	0.0	0.0
Total Delay	10.1	12.3	9.3	0.1	221.0	89.5	0.2
LOS	B	B	A	A	F	F	A
Approach Delay		12.1	8.0			106.5	
Approach LOS		B	A			F	

Intersection Summary

Cycle Length: 114
 Actuated Cycle Length: 114
 Offset: 2 (2%), Referenced to phase 4:EBTL and 8:WBT, Start of Green
 Natural Cycle: 60
 Control Type: Actuated-Coordinated
 Maximum v/c Ratio: 1.34
 Intersection Signal Delay: 37.3
 Intersection LOS: D
 Intersection Capacity Utilization 51.7%
 ICU Level of Service A
 Analysis Period (min) 15

Splits and Phases: 5: Powers Blvd NB Ramp & Old Ranch Rd

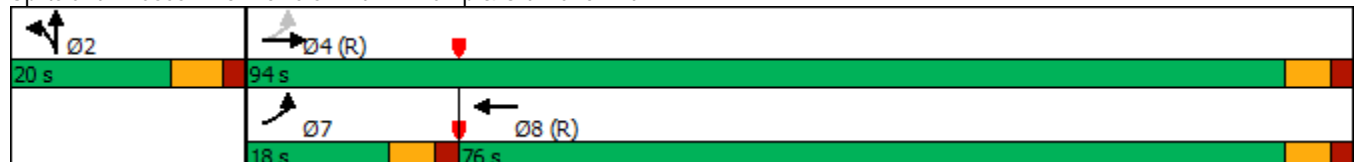

HCM 6th Signalized Intersection Summary
5: Powers Blvd NB Ramp & Old Ranch Rd

2025 Total AM
09/06/2023



Movement	EBL	EBT	EBR	WBL	WBT	WBR	NBL	NBT	NBR	SBL	SBT	SBR
Lane Configurations	↶	↷			↷	↶	↶	↷	↶			
Traffic Volume (veh/h)	55	470	0	0	801	138	273	0	316	0	0	0
Future Volume (veh/h)	55	470	0	0	801	138	273	0	316	0	0	0
Initial Q (Qb), veh	0	0	0	0	0	0	0	0	0			
Ped-Bike Adj(A_pbT)	1.00		1.00	1.00		1.00	1.00		1.00			
Parking Bus, Adj	1.00	1.00	1.00	1.00	1.00	1.00	1.00	1.00	1.00			
Work Zone On Approach		No			No			No				
Adj Sat Flow, veh/h/ln	1870	1870	0	0	1870	1870	1870	1870	1870			
Adj Flow Rate, veh/h	71	610	0	0	1040	0	491	0	0			
Peak Hour Factor	0.77	0.77	0.77	0.77	0.77	0.77	0.77	0.77	0.77			
Percent Heavy Veh, %	2	2	0	0	2	2	2	2	2			
Cap, veh/h	422	2743	0	0	2445		422	0				
Arrive On Green	0.03	0.77	0.00	0.00	0.69	0.00	0.12	0.00	0.00			
Sat Flow, veh/h	1781	3647	0	0	3647	1585	3563	0	1585			
Grp Volume(v), veh/h	71	610	0	0	1040	0	491	0	0			
Grp Sat Flow(s),veh/h/ln	1781	1777	0	0	1777	1585	1781	0	1585			
Q Serve(g_s), s	1.2	5.4	0.0	0.0	14.7	0.0	13.5	0.0	0.0			
Cycle Q Clear(g_c), s	1.2	5.4	0.0	0.0	14.7	0.0	13.5	0.0	0.0			
Prop In Lane	1.00		0.00	0.00		1.00	1.00		1.00			
Lane Grp Cap(c), veh/h	422	2743	0	0	2445		422	0				
V/C Ratio(X)	0.17	0.22	0.00	0.00	0.43		1.16	0.00				
Avail Cap(c_a), veh/h	554	2743	0	0	2445		422	0				
HCM Platoon Ratio	1.00	1.00	1.00	1.00	1.00	1.00	1.00	1.00	1.00			
Upstream Filter(l)	0.97	0.97	0.00	0.00	1.00	0.00	1.00	0.00	0.00			
Uniform Delay (d), s/veh	5.5	3.6	0.0	0.0	7.8	0.0	50.3	0.0	0.0			
Incr Delay (d2), s/veh	0.2	0.2	0.0	0.0	0.5	0.0	96.8	0.0	0.0			
Initial Q Delay(d3),s/veh	0.0	0.0	0.0	0.0	0.0	0.0	0.0	0.0	0.0			
%ile BackOfQ(50%),veh/ln	0.4	1.7	0.0	0.0	5.3	0.0	11.7	0.0	0.0			
Unsig. Movement Delay, s/veh												
LnGrp Delay(d),s/veh	5.7	3.8	0.0	0.0	8.4	0.0	147.1	0.0	0.0			
LnGrp LOS	A	A	A	A	A		F	A				
Approach Vol, veh/h		681			1040			491				
Approach Delay, s/veh		4.0			8.4			147.1				
Approach LOS		A			A			F				
Timer - Assigned Phs		2		4			7	8				
Phs Duration (G+Y+Rc), s		20.0		94.0			9.6	84.4				
Change Period (Y+Rc), s		6.5		6.0			6.0	6.0				
Max Green Setting (Gmax), s		13.5		88.0			12.0	70.0				
Max Q Clear Time (g_c+I1), s		15.5		7.4			3.2	16.7				
Green Ext Time (p_c), s		0.0		4.9			0.1	10.0				

Intersection Summary

HCM 6th Ctrl Delay	37.8
HCM 6th LOS	D

Notes

User approved volume balancing among the lanes for turning movement.
Unsignalized Delay for [NBR, WBR] is excluded from calculations of the approach delay and intersection delay.

Timings

2025 Total PM

09/06/2023

5: Powers Blvd NB Ramp & Old Ranch Rd



Lane Group	EBL	EBT	WBT	WBR	NBL	NBT	NBR
Lane Configurations	↙	↑↑	↑↑	↘	↙	↕	↘
Traffic Volume (vph)	44	400	353	108	195	2	221
Future Volume (vph)	44	400	353	108	195	2	221
Turn Type	pm+pt	NA	NA	Free	Split	NA	Free
Protected Phases	7	4	8		2	2	
Permitted Phases	4			Free			Free
Detector Phase	7	4	8		2	2	
Switch Phase							
Minimum Initial (s)	4.0	12.0	12.0		6.0	6.0	
Minimum Split (s)	10.0	24.0	24.0		20.0	20.0	
Total Split (s)	18.0	94.0	76.0		20.0	20.0	
Total Split (%)	15.8%	82.5%	66.7%		17.5%	17.5%	
Yellow Time (s)	4.0	4.0	4.0		4.5	4.5	
All-Red Time (s)	2.0	2.0	2.0		2.0	2.0	
Lost Time Adjust (s)	0.0	0.0	0.0		0.0	0.0	
Total Lost Time (s)	6.0	6.0	6.0		6.5	6.5	
Lead/Lag	Lead		Lag				
Lead-Lag Optimize?	Yes		Yes				
Recall Mode	None	C-Max	C-Max		Max	Max	
Act Effct Green (s)	88.0	88.0	78.2	114.0	13.5	13.5	114.0
Actuated g/C Ratio	0.77	0.77	0.69	1.00	0.12	0.12	1.00
v/c Ratio	0.06	0.15	0.15	0.07	0.75	0.61	0.09
Control Delay	7.1	8.8	6.9	0.1	72.0	39.0	0.1
Queue Delay	0.0	0.0	0.0	0.0	0.0	0.0	0.0
Total Delay	7.1	8.8	6.9	0.1	72.0	39.0	0.1
LOS	A	A	A	A	E	D	A
Approach Delay		8.6	5.3			38.1	
Approach LOS		A	A			D	

Intersection Summary

Cycle Length: 114
 Actuated Cycle Length: 114
 Offset: 2 (2%), Referenced to phase 4:EBTL and 8:WBT, Start of Green
 Natural Cycle: 55
 Control Type: Actuated-Coordinated
 Maximum v/c Ratio: 0.75
 Intersection Signal Delay: 16.8
 Intersection LOS: B
 Intersection Capacity Utilization 44.8%
 ICU Level of Service A
 Analysis Period (min) 15

Splits and Phases: 5: Powers Blvd NB Ramp & Old Ranch Rd



HCM 6th Signalized Intersection Summary
5: Powers Blvd NB Ramp & Old Ranch Rd

2025 Total PM
09/06/2023



Movement	EBL	EBT	EBR	WBL	WBT	WBR	NBL	NBT	NBR	SBL	SBT	SBR
Lane Configurations	↘	↑↑			↑↑	↗	↘	↕	↗			
Traffic Volume (veh/h)	44	400	0	0	353	108	195	2	221	0	0	0
Future Volume (veh/h)	44	400	0	0	353	108	195	2	221	0	0	0
Initial Q (Qb), veh	0	0	0	0	0	0	0	0	0			
Ped-Bike Adj(A_pbT)	1.00		1.00	1.00		1.00	1.00		1.00			
Parking Bus, Adj	1.00	1.00	1.00	1.00	1.00	1.00	1.00	1.00	1.00			
Work Zone On Approach		No			No			No				
Adj Sat Flow, veh/h/ln	1870	1870	0	0	1870	1870	1870	1870	1870			
Adj Flow Rate, veh/h	45	408	0	0	360	0	274	0	0			
Peak Hour Factor	0.98	0.98	0.98	0.98	0.98	0.98	0.98	0.98	0.98			
Percent Heavy Veh, %	2	2	0	0	2	2	2	2	2			
Cap, veh/h	783	2743	0	0	2461		422	0				
Arrive On Green	0.03	0.77	0.00	0.00	0.69	0.00	0.12	0.00	0.00			
Sat Flow, veh/h	1781	3647	0	0	3647	1585	3563	0	1585			
Grp Volume(v), veh/h	45	408	0	0	360	0	274	0	0			
Grp Sat Flow(s),veh/h/ln	1781	1777	0	0	1777	1585	1781	0	1585			
Q Serve(g_s), s	0.8	3.4	0.0	0.0	3.9	0.0	8.4	0.0	0.0			
Cycle Q Clear(g_c), s	0.8	3.4	0.0	0.0	3.9	0.0	8.4	0.0	0.0			
Prop In Lane	1.00		0.00	0.00		1.00	1.00		1.00			
Lane Grp Cap(c), veh/h	783	2743	0	0	2461		422	0				
V/C Ratio(X)	0.06	0.15	0.00	0.00	0.15		0.65	0.00				
Avail Cap(c_a), veh/h	923	2743	0	0	2461		422	0				
HCM Platoon Ratio	1.00	1.00	1.00	1.00	1.00	1.00	1.00	1.00	1.00			
Upstream Filter(I)	0.99	0.99	0.00	0.00	1.00	0.00	1.00	0.00	0.00			
Uniform Delay (d), s/veh	4.2	3.3	0.0	0.0	6.0	0.0	48.0	0.0	0.0			
Incr Delay (d2), s/veh	0.0	0.1	0.0	0.0	0.1	0.0	7.5	0.0	0.0			
Initial Q Delay(d3),s/veh	0.0	0.0	0.0	0.0	0.0	0.0	0.0	0.0	0.0			
%ile BackOfQ(50%),veh/ln	0.3	1.0	0.0	0.0	1.4	0.0	4.2	0.0	0.0			
Unsig. Movement Delay, s/veh												
LnGrp Delay(d),s/veh	4.2	3.5	0.0	0.0	6.1	0.0	55.5	0.0	0.0			
LnGrp LOS	A	A	A	A	A		E	A				
Approach Vol, veh/h		453			360			274				
Approach Delay, s/veh		3.5			6.1			55.5				
Approach LOS		A			A			E				
Timer - Assigned Phs		2		4			7	8				
Phs Duration (G+Y+Rc), s		20.0		94.0			9.0	85.0				
Change Period (Y+Rc), s		6.5		6.0			6.0	6.0				
Max Green Setting (Gmax), s		13.5		88.0			12.0	70.0				
Max Q Clear Time (g_c+I1), s		10.4		5.4			2.8	5.9				
Green Ext Time (p_c), s		0.3		3.1			0.0	2.7				

Intersection Summary

HCM 6th Ctrl Delay	17.5
HCM 6th LOS	B

Notes

User approved volume balancing among the lanes for turning movement.
Unsignalized Delay for [NBR, WBR] is excluded from calculations of the approach delay and intersection delay.

Timings
5: Powers Blvd NB Ramp & Old Ranch Rd



Lane Group	EBL	EBT	WBT	WBR	NBL	NBT	NBR
Lane Configurations	↖	↑↑	↑↑	↗	↖	↕	↗
Traffic Volume (vph)	50	620	1075	186	346	0	426
Future Volume (vph)	50	620	1075	186	346	0	426
Turn Type	pm+pt	NA	NA	Free	Split	NA	Free
Protected Phases	7	4	8		2	2	
Permitted Phases	4			Free			Free
Detector Phase	7	4	8		2	2	
Switch Phase							
Minimum Initial (s)	4.0	12.0	12.0		6.0	6.0	
Minimum Split (s)	10.0	24.0	24.0		20.0	20.0	
Total Split (s)	18.0	94.0	76.0		20.0	20.0	
Total Split (%)	15.8%	82.5%	66.7%		17.5%	17.5%	
Yellow Time (s)	4.0	4.0	4.0		4.5	4.5	
All-Red Time (s)	2.0	2.0	2.0		2.0	2.0	
Lost Time Adjust (s)	0.0	0.0	0.0		0.0	0.0	
Total Lost Time (s)	6.0	6.0	6.0		6.5	6.5	
Lead/Lag	Lead		Lag				
Lead-Lag Optimize?	Yes		Yes				
Recall Mode	None	C-Max	C-Max		Max	Max	
Act Effct Green (s)	88.0	88.0	77.9	114.0	13.5	13.5	114.0
Actuated g/C Ratio	0.77	0.77	0.68	1.00	0.12	0.12	1.00
v/c Ratio	0.23	0.29	0.58	0.15	1.76	1.31	0.21
Control Delay	8.8	11.3	11.2	0.2	392.2	196.6	0.3
Queue Delay	0.0	0.0	0.0	0.0	0.0	0.0	0.0
Total Delay	8.8	11.3	11.2	0.2	392.2	196.6	0.3
LOS	A	B	B	A	F	F	A
Approach Delay		11.2	9.6			202.1	
Approach LOS		B	A			F	

Intersection Summary

Cycle Length: 114
 Actuated Cycle Length: 114
 Offset: 2 (2%), Referenced to phase 4:EBTL and 8:WBT, Start of Green
 Natural Cycle: 65
 Control Type: Actuated-Coordinated
 Maximum v/c Ratio: 1.76
 Intersection Signal Delay: 64.9
 Intersection Capacity Utilization 62.4%
 Analysis Period (min) 15
 Intersection LOS: E
 ICU Level of Service B

Splits and Phases: 5: Powers Blvd NB Ramp & Old Ranch Rd



HCM 6th Signalized Intersection Summary
5: Powers Blvd NB Ramp & Old Ranch Rd

2045 Background AM

09/06/2023

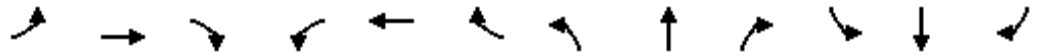

Movement	EBL	EBT	EBR	WBL	WBT	WBR	NBL	NBT	NBR	SBL	SBT	SBR
Lane Configurations	↘	↑↑			↑↑	↗	↘	↕	↗			
Traffic Volume (veh/h)	50	620	0	0	1075	186	346	0	426	0	0	0
Future Volume (veh/h)	50	620	0	0	1075	186	346	0	426	0	0	0
Initial Q (Qb), veh	0	0	0	0	0	0	0	0	0			
Ped-Bike Adj(A_pbT)	1.00		1.00	1.00		1.00	1.00		1.00			
Parking Bus, Adj	1.00	1.00	1.00	1.00	1.00	1.00	1.00	1.00	1.00			
Work Zone On Approach		No			No			No				
Adj Sat Flow, veh/h/ln	1870	1870	0	0	1870	1870	1870	1870	1870			
Adj Flow Rate, veh/h	65	805	0	0	1396	0	637	0	0			
Peak Hour Factor	0.77	0.77	0.77	0.77	0.77	0.77	0.77	0.77	0.77			
Percent Heavy Veh, %	2	2	0	0	2	2	2	2	2			
Cap, veh/h	306	2743	0	0	2447		422	0				
Arrive On Green	0.02	0.52	0.00	0.00	0.69	0.00	0.12	0.00	0.00			
Sat Flow, veh/h	1781	3647	0	0	3647	1585	3563	0	1585			
Grp Volume(v), veh/h	65	805	0	0	1396	0	637	0	0			
Grp Sat Flow(s),veh/h/ln	1781	1777	0	0	1777	1585	1781	0	1585			
Q Serve(g_s), s	1.1	14.7	0.0	0.0	23.0	0.0	13.5	0.0	0.0			
Cycle Q Clear(g_c), s	1.1	14.7	0.0	0.0	23.0	0.0	13.5	0.0	0.0			
Prop In Lane	1.00		0.00	0.00		1.00	1.00		1.00			
Lane Grp Cap(c), veh/h	306	2743	0	0	2447		422	0				
V/C Ratio(X)	0.21	0.29	0.00	0.00	0.57		1.51	0.00				
Avail Cap(c_a), veh/h	439	2743	0	0	2447		422	0				
HCM Platoon Ratio	0.67	0.67	1.00	1.00	1.00	1.00	1.00	1.00	1.00			
Upstream Filter(I)	0.95	0.95	0.00	0.00	1.00	0.00	1.00	0.00	0.00			
Uniform Delay (d), s/veh	7.5	9.8	0.0	0.0	9.1	0.0	50.3	0.0	0.0			
Incr Delay (d2), s/veh	0.3	0.3	0.0	0.0	1.0	0.0	241.5	0.0	0.0			
Initial Q Delay(d3),s/veh	0.0	0.0	0.0	0.0	0.0	0.0	0.0	0.0	0.0			
%ile BackOfQ(50%),veh/ln	0.4	6.4	0.0	0.0	8.3	0.0	20.1	0.0	0.0			
Unsig. Movement Delay, s/veh												
LnGrp Delay(d),s/veh	7.8	10.1	0.0	0.0	10.1	0.0	291.7	0.0	0.0			
LnGrp LOS	A	B	A	A	B		F	A				
Approach Vol, veh/h		870			1396			637				
Approach Delay, s/veh		9.9			10.1			291.7				
Approach LOS		A			B			F				
Timer - Assigned Phs		2		4			7	8				
Phs Duration (G+Y+Rc), s		20.0		94.0			9.5	84.5				
Change Period (Y+Rc), s		6.5		6.0			6.0	6.0				
Max Green Setting (Gmax), s		13.5		88.0			12.0	70.0				
Max Q Clear Time (g_c+I1), s		15.5		16.7			3.1	25.0				
Green Ext Time (p_c), s		0.0		7.0			0.1	15.5				

Intersection Summary

HCM 6th Ctrl Delay	71.8
HCM 6th LOS	E

Notes

User approved volume balancing among the lanes for turning movement.
Unsignalized Delay for [NBR, WBR] is excluded from calculations of the approach delay and intersection delay.

Timings
5: Powers Blvd NB Ramp & Old Ranch Rd



Lane Group	EBL	EBT	WBT	WBR	NBL	NBT	NBR
Lane Configurations	↶	↷	↷	↷	↶	↷	↷
Traffic Volume (vph)	43	530	462	146	193	3	298
Future Volume (vph)	43	530	462	146	193	3	298
Turn Type	pm+pt	NA	NA	Free	Split	NA	Free
Protected Phases	7	4	8		2	2	
Permitted Phases	4			Free			Free
Detector Phase	7	4	8		2	2	
Switch Phase							
Minimum Initial (s)	4.0	12.0	12.0		6.0	6.0	
Minimum Split (s)	10.0	24.0	24.0		20.0	20.0	
Total Split (s)	18.0	94.0	76.0		20.0	20.0	
Total Split (%)	15.8%	82.5%	66.7%		17.5%	17.5%	
Yellow Time (s)	4.0	4.0	4.0		4.5	4.5	
All-Red Time (s)	2.0	2.0	2.0		2.0	2.0	
Lost Time Adjust (s)	0.0	0.0	0.0		0.0	0.0	
Total Lost Time (s)	6.0	6.0	6.0		6.5	6.5	
Lead/Lag	Lead		Lag				
Lead-Lag Optimize?	Yes		Yes				
Recall Mode	None	C-Max	C-Max		Max	Max	
Act Effct Green (s)	88.0	88.0	78.2	114.0	13.5	13.5	114.0
Actuated g/C Ratio	0.77	0.77	0.69	1.00	0.12	0.12	1.00
v/c Ratio	0.06	0.20	0.19	0.09	0.88	0.56	0.11
Control Delay	5.4	7.4	7.2	0.1	88.9	19.2	0.1
Queue Delay	0.0	0.0	0.0	0.0	0.0	0.0	0.0
Total Delay	5.4	7.4	7.2	0.1	88.9	19.2	0.1
LOS	A	A	A	A	F	B	A
Approach Delay		7.3	5.5			37.2	
Approach LOS		A	A			D	

Intersection Summary

Cycle Length: 114
 Actuated Cycle Length: 114
 Offset: 2 (2%), Referenced to phase 4:EBTL and 8:WBT, Start of Green
 Natural Cycle: 55
 Control Type: Actuated-Coordinated
 Maximum v/c Ratio: 0.88
 Intersection Signal Delay: 15.5
 Intersection LOS: B
 Intersection Capacity Utilization 49.0%
 ICU Level of Service A
 Analysis Period (min) 15

Splits and Phases: 5: Powers Blvd NB Ramp & Old Ranch Rd



HCM 6th Signalized Intersection Summary
5: Powers Blvd NB Ramp & Old Ranch Rd

2045 Background PM
09/06/2023



Movement	EBL	EBT	EBR	WBL	WBT	WBR	NBL	NBT	NBR	SBL	SBT	SBR
Lane Configurations	↘	↑↑			↑↑	↗	↘	↕	↗			
Traffic Volume (veh/h)	43	530	0	0	462	146	193	3	298	0	0	0
Future Volume (veh/h)	43	530	0	0	462	146	193	3	298	0	0	0
Initial Q (Qb), veh	0	0	0	0	0	0	0	0	0			
Ped-Bike Adj(A_pbT)	1.00		1.00	1.00		1.00	1.00		1.00			
Parking Bus, Adj	1.00	1.00	1.00	1.00	1.00	1.00	1.00	1.00	1.00			
Work Zone On Approach		No			No			No				
Adj Sat Flow, veh/h/ln	1870	1870	0	0	1870	1870	1870	1870	1870			
Adj Flow Rate, veh/h	44	541	0	0	471	0	132	0	0			
Peak Hour Factor	0.98	0.98	0.98	0.98	0.98	0.98	0.98	0.98	0.98			
Percent Heavy Veh, %	2	2	0	0	2	2	2	2	2			
Cap, veh/h	706	2743	0	0	2462		211	0				
Arrive On Green	0.02	0.52	0.00	0.00	0.69	0.00	0.12	0.00	0.00			
Sat Flow, veh/h	1781	3647	0	0	3647	1585	1781	0	3170			
Grp Volume(v), veh/h	44	541	0	0	471	0	132	0	0			
Grp Sat Flow(s),veh/h/ln	1781	1777	0	0	1777	1585	1781	0	1585			
Q Serve(g_s), s	0.8	9.3	0.0	0.0	5.3	0.0	8.0	0.0	0.0			
Cycle Q Clear(g_c), s	0.8	9.3	0.0	0.0	5.3	0.0	8.0	0.0	0.0			
Prop In Lane	1.00		0.00	0.00		1.00	1.00		1.00			
Lane Grp Cap(c), veh/h	706	2743	0	0	2462		211	0				
V/C Ratio(X)	0.06	0.20	0.00	0.00	0.19		0.63	0.00				
Avail Cap(c_a), veh/h	847	2743	0	0	2462		211	0				
HCM Platoon Ratio	0.67	0.67	1.00	1.00	1.00	1.00	1.00	1.00	1.00			
Upstream Filter(I)	0.99	0.99	0.00	0.00	1.00	0.00	1.00	0.00	0.00			
Uniform Delay (d), s/veh	4.3	8.5	0.0	0.0	6.2	0.0	47.8	0.0	0.0			
Incr Delay (d2), s/veh	0.0	0.2	0.0	0.0	0.2	0.0	13.2	0.0	0.0			
Initial Q Delay(d3),s/veh	0.0	0.0	0.0	0.0	0.0	0.0	0.0	0.0	0.0			
%ile BackOfQ(50%),veh/ln	0.3	3.7	0.0	0.0	1.9	0.0	4.3	0.0	0.0			
Unsig. Movement Delay, s/veh												
LnGrp Delay(d),s/veh	4.4	8.7	0.0	0.0	6.4	0.0	61.1	0.0	0.0			
LnGrp LOS	A	A	A	A	A		E	A				
Approach Vol, veh/h		585			471			132				
Approach Delay, s/veh		8.4			6.4			61.1				
Approach LOS		A			A			E				
Timer - Assigned Phs		2		4			7	8				
Phs Duration (G+Y+Rc), s		20.0		94.0			9.0	85.0				
Change Period (Y+Rc), s		6.5		6.0			6.0	6.0				
Max Green Setting (Gmax), s		13.5		88.0			12.0	70.0				
Max Q Clear Time (g_c+I1), s		10.0		11.3			2.8	7.3				
Green Ext Time (p_c), s		0.1		4.2			0.0	3.6				

Intersection Summary

HCM 6th Ctrl Delay	13.4
HCM 6th LOS	B

Notes

User approved volume balancing among the lanes for turning movement.
Unsignalized Delay for [NBR, WBR] is excluded from calculations of the approach delay and intersection delay.

Timings

2045 Total AM

09/06/2023

5: Powers Blvd NB Ramp & Old Ranch Rd



Lane Group	EBL	EBT	WBT	WBR	NBL	NBT	NBR
Lane Configurations	↘	↑↑	↑↑	↗	↘	↕	↗
Traffic Volume (vph)	68	629	1078	186	362	0	426
Future Volume (vph)	68	629	1078	186	362	0	426
Turn Type	pm+pt	NA	NA	Free	Split	NA	Free
Protected Phases	7	4	8		2	2	
Permitted Phases	4			Free			Free
Detector Phase	7	4	8		2	2	
Switch Phase							
Minimum Initial (s)	4.0	12.0	12.0		6.0	6.0	
Minimum Split (s)	10.0	24.0	24.0		20.0	20.0	
Total Split (s)	12.0	73.0	61.0		41.0	41.0	
Total Split (%)	10.5%	64.0%	53.5%		36.0%	36.0%	
Yellow Time (s)	4.0	4.0	4.0		4.5	4.5	
All-Red Time (s)	2.0	2.0	2.0		2.0	2.0	
Lost Time Adjust (s)	0.0	0.0	0.0		0.0	0.0	
Total Lost Time (s)	6.0	6.0	6.0		6.5	6.5	
Lead/Lag	Lead		Lag				
Lead-Lag Optimize?	Yes		Yes				
Recall Mode	None	C-Max	C-Max		Max	Max	
Act Effct Green (s)	67.0	67.0	57.4	114.0	34.5	34.5	114.0
Actuated g/C Ratio	0.59	0.59	0.50	1.00	0.30	0.30	1.00
v/c Ratio	0.55	0.39	0.79	0.15	0.70	0.66	0.22
Control Delay	25.1	17.7	28.0	0.2	43.9	31.9	0.3
Queue Delay	0.0	0.0	0.0	0.0	0.0	0.0	0.0
Total Delay	25.1	17.7	28.0	0.2	43.9	31.9	0.3
LOS	C	B	C	A	D	C	A
Approach Delay		18.5	23.9			26.0	
Approach LOS		B	C			C	

Intersection Summary

Cycle Length: 114
 Actuated Cycle Length: 114
 Offset: 2 (2%), Referenced to phase 4:EBTL and 8:WBT, Start of Green
 Natural Cycle: 70
 Control Type: Actuated-Coordinated
 Maximum v/c Ratio: 0.79
 Intersection Signal Delay: 23.1
 Intersection LOS: C
 Intersection Capacity Utilization 63.3%
 ICU Level of Service B
 Analysis Period (min) 15

Splits and Phases: 5: Powers Blvd NB Ramp & Old Ranch Rd

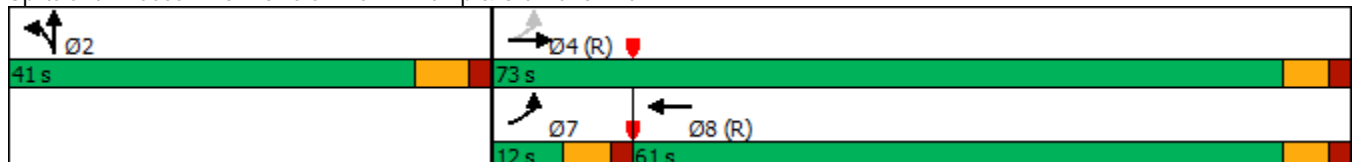

HCM 6th Signalized Intersection Summary
5: Powers Blvd NB Ramp & Old Ranch Rd

2045 Total AM
09/06/2023



Movement	EBL	EBT	EBR	WBL	WBT	WBR	NBL	NBT	NBR	SBL	SBT	SBR
Lane Configurations	↘	↑↑			↑↑	↗	↘	↕	↗			
Traffic Volume (veh/h)	68	629	0	0	1078	186	362	0	426	0	0	0
Future Volume (veh/h)	68	629	0	0	1078	186	362	0	426	0	0	0
Initial Q (Qb), veh	0	0	0	0	0	0	0	0	0			
Ped-Bike Adj(A_pbT)	1.00		1.00	1.00		1.00	1.00		1.00			
Parking Bus, Adj	1.00	1.00	1.00	1.00	1.00	1.00	1.00	1.00	1.00			
Work Zone On Approach		No			No			No				
Adj Sat Flow, veh/h/ln	1870	1870	0	0	1870	1870	1870	1870	1870			
Adj Flow Rate, veh/h	88	817	0	0	1400	0	655	0	0			
Peak Hour Factor	0.77	0.77	0.77	0.77	0.77	0.77	0.77	0.77	0.77			
Percent Heavy Veh, %	2	2	0	0	2	2	2	2	2			
Cap, veh/h	197	2089	0	0	1765		1078	0				
Arrive On Green	0.01	0.19	0.00	0.00	0.50	0.00	0.30	0.00	0.00			
Sat Flow, veh/h	1781	3647	0	0	3647	1585	3563	0	1585			
Grp Volume(v), veh/h	88	817	0	0	1400	0	655	0	0			
Grp Sat Flow(s),veh/h/ln	1781	1777	0	0	1777	1585	1781	0	1585			
Q Serve(g_s), s	2.6	22.9	0.0	0.0	37.3	0.0	17.9	0.0	0.0			
Cycle Q Clear(g_c), s	2.6	22.9	0.0	0.0	37.3	0.0	17.9	0.0	0.0			
Prop In Lane	1.00		0.00	0.00		1.00	1.00		1.00			
Lane Grp Cap(c), veh/h	197	2089	0	0	1765		1078	0				
V/C Ratio(X)	0.45	0.39	0.00	0.00	0.79		0.61	0.00				
Avail Cap(c_a), veh/h	222	2089	0	0	1765		1078	0				
HCM Platoon Ratio	0.33	0.33	1.00	1.00	1.00	1.00	1.00	1.00	1.00			
Upstream Filter(l)	0.94	0.94	0.00	0.00	1.00	0.00	1.00	0.00	0.00			
Uniform Delay (d), s/veh	21.4	28.2	0.0	0.0	23.8	0.0	34.0	0.0	0.0			
Incr Delay (d2), s/veh	1.5	0.5	0.0	0.0	3.8	0.0	2.5	0.0	0.0			
Initial Q Delay(d3),s/veh	0.0	0.0	0.0	0.0	0.0	0.0	0.0	0.0	0.0			
%ile BackOfQ(50%),veh/ln	1.2	11.0	0.0	0.0	16.0	0.0	8.1	0.0	0.0			
Unsig. Movement Delay, s/veh												
LnGrp Delay(d),s/veh	22.9	28.7	0.0	0.0	27.6	0.0	36.5	0.0	0.0			
LnGrp LOS	C	C	A	A	C		D	A				
Approach Vol, veh/h		905			1400			655				
Approach Delay, s/veh		28.1			27.6			36.5				
Approach LOS		C			C			D				
Timer - Assigned Phs		2		4			7	8				
Phs Duration (G+Y+Rc), s		41.0		73.0			10.4	62.6				
Change Period (Y+Rc), s		6.5		6.0			6.0	6.0				
Max Green Setting (Gmax), s		34.5		67.0			6.0	55.0				
Max Q Clear Time (g_c+l1), s		19.9		24.9			4.6	39.3				
Green Ext Time (p_c), s		2.2		7.0			0.0	9.3				

Intersection Summary

HCM 6th Ctrl Delay	29.7
HCM 6th LOS	C

Notes

User approved volume balancing among the lanes for turning movement.
Unsignalized Delay for [NBR, WBR] is excluded from calculations of the approach delay and intersection delay.

Timings
5: Powers Blvd NB Ramp & Old Ranch Rd

2045 Total PM
09/06/2023



Lane Group	EBL	EBT	WBT	WBR	NBL	NBT	NBR
Lane Configurations	↙	↑↑	↑↑	↗	↙	↕	↗
Traffic Volume (vph)	55	536	472	146	245	3	298
Future Volume (vph)	55	536	472	146	245	3	298
Turn Type	pm+pt	NA	NA	Free	Split	NA	Free
Protected Phases	7	4	8		2	2	
Permitted Phases	4			Free			Free
Detector Phase	7	4	8		2	2	
Switch Phase							
Minimum Initial (s)	4.0	12.0	12.0		6.0	6.0	
Minimum Split (s)	10.0	24.0	24.0		20.0	20.0	
Total Split (s)	18.0	94.0	76.0		20.0	20.0	
Total Split (%)	15.8%	82.5%	66.7%		17.5%	17.5%	
Yellow Time (s)	4.0	4.0	4.0		4.5	4.5	
All-Red Time (s)	2.0	2.0	2.0		2.0	2.0	
Lost Time Adjust (s)	0.0	0.0	0.0		0.0	0.0	
Total Lost Time (s)	6.0	6.0	6.0		6.5	6.5	
Lead/Lag	Lead		Lag				
Lead-Lag Optimize?	Yes		Yes				
Recall Mode	None	C-Max	C-Max		Max	Max	
Act Effct Green (s)	88.0	88.0	78.0	114.0	13.5	13.5	114.0
Actuated g/C Ratio	0.77	0.77	0.68	1.00	0.12	0.12	1.00
v/c Ratio	0.08	0.20	0.20	0.09	0.96	0.77	0.12
Control Delay	11.5	14.0	7.3	0.1	106.1	50.8	0.2
Queue Delay	0.0	0.0	0.0	0.0	0.0	0.0	0.0
Total Delay	11.5	14.0	7.3	0.1	106.1	50.8	0.2
LOS	B	B	A	A	F	D	A
Approach Delay		13.7	5.6			53.6	
Approach LOS		B	A			D	

Intersection Summary

Cycle Length: 114
 Actuated Cycle Length: 114
 Offset: 2 (2%), Referenced to phase 4:EBTL and 8:WBT, Start of Green
 Natural Cycle: 55
 Control Type: Actuated-Coordinated
 Maximum v/c Ratio: 0.96
 Intersection Signal Delay: 23.3
 Intersection Capacity Utilization 49.0%
 Analysis Period (min) 15

Intersection LOS: C
 ICU Level of Service A

Splits and Phases: 5: Powers Blvd NB Ramp & Old Ranch Rd



HCM 6th Signalized Intersection Summary
5: Powers Blvd NB Ramp & Old Ranch Rd

2045 Total PM
09/06/2023



Movement	EBL	EBT	EBR	WBL	WBT	WBR	NBL	NBT	NBR	SBL	SBT	SBR
Lane Configurations	↘	↑↑			↑↑	↗	↘	↕	↗			
Traffic Volume (veh/h)	55	536	0	0	472	146	245	3	298	0	0	0
Future Volume (veh/h)	55	536	0	0	472	146	245	3	298	0	0	0
Initial Q (Qb), veh	0	0	0	0	0	0	0	0	0			
Ped-Bike Adj(A_pbT)	1.00		1.00	1.00		1.00	1.00		1.00			
Parking Bus, Adj	1.00	1.00	1.00	1.00	1.00	1.00	1.00	1.00	1.00			
Work Zone On Approach		No			No			No				
Adj Sat Flow, veh/h/ln	1870	1870	0	0	1870	1870	1870	1870	1870			
Adj Flow Rate, veh/h	56	547	0	0	482	0	354	0	0			
Peak Hour Factor	0.98	0.98	0.98	0.98	0.98	0.98	0.98	0.98	0.98			
Percent Heavy Veh, %	2	2	0	0	2	2	2	2	2			
Cap, veh/h	701	2743	0	0	2453		422	0				
Arrive On Green	0.02	0.52	0.00	0.00	0.69	0.00	0.12	0.00	0.00			
Sat Flow, veh/h	1781	3647	0	0	3647	1585	3563	0	1585			
Grp Volume(v), veh/h	56	547	0	0	482	0	354	0	0			
Grp Sat Flow(s),veh/h/ln	1781	1777	0	0	1777	1585	1781	0	1585			
Q Serve(g_s), s	1.0	9.4	0.0	0.0	5.5	0.0	11.1	0.0	0.0			
Cycle Q Clear(g_c), s	1.0	9.4	0.0	0.0	5.5	0.0	11.1	0.0	0.0			
Prop In Lane	1.00		0.00	0.00		1.00	1.00		1.00			
Lane Grp Cap(c), veh/h	701	2743	0	0	2453		422	0				
V/C Ratio(X)	0.08	0.20	0.00	0.00	0.20		0.84	0.00				
Avail Cap(c_a), veh/h	836	2743	0	0	2453		422	0				
HCM Platoon Ratio	0.67	0.67	1.00	1.00	1.00	1.00	1.00	1.00	1.00			
Upstream Filter(I)	0.98	0.98	0.00	0.00	1.00	0.00	1.00	0.00	0.00			
Uniform Delay (d), s/veh	4.4	8.6	0.0	0.0	6.3	0.0	49.2	0.0	0.0			
Incr Delay (d2), s/veh	0.0	0.2	0.0	0.0	0.2	0.0	17.8	0.0	0.0			
Initial Q Delay(d3),s/veh	0.0	0.0	0.0	0.0	0.0	0.0	0.0	0.0	0.0			
%ile BackOfQ(50%),veh/ln	0.3	3.8	0.0	0.0	2.0	0.0	6.0	0.0	0.0			
Unsig. Movement Delay, s/veh												
LnGrp Delay(d),s/veh	4.4	8.7	0.0	0.0	6.5	0.0	67.0	0.0	0.0			
LnGrp LOS	A	A	A	A	A		E	A				
Approach Vol, veh/h		603			482			354				
Approach Delay, s/veh		8.3			6.5			67.0				
Approach LOS		A			A			E				
Timer - Assigned Phs		2		4			7	8				
Phs Duration (G+Y+Rc), s		20.0		94.0			9.3	84.7				
Change Period (Y+Rc), s		6.5		6.0			6.0	6.0				
Max Green Setting (Gmax), s		13.5		88.0			12.0	70.0				
Max Q Clear Time (g_c+I1), s		13.1		11.4			3.0	7.5				
Green Ext Time (p_c), s		0.1		4.3			0.1	3.7				

Intersection Summary

HCM 6th Ctrl Delay				22.2								
HCM 6th LOS				C								

Notes

User approved volume balancing among the lanes for turning movement.
Unsignalized Delay for [NBR, WBR] is excluded from calculations of the approach delay and intersection delay.

Intersection												
Int Delay, s/veh	4.9											
Movement	EBL	EBT	EBR	WBL	WBT	WBR	NBL	NBT	NBR	SBL	SBT	SBR
Lane Configurations		↕			↕		↕	↕		↕	↕	
Traffic Vol, veh/h	0	0	62	18	0	0	22	19	6	0	53	0
Future Vol, veh/h	0	0	62	18	0	0	22	19	6	0	53	0
Conflicting Peds, #/hr	0	0	0	0	0	0	0	0	0	0	0	0
Sign Control	Stop	Stop	Stop	Stop	Stop	Stop	Free	Free	Free	Free	Free	Free
RT Channelized	-	-	None	-	-	None	-	-	None	-	-	None
Storage Length	-	-	-	-	-	-	0	-	-	0	-	-
Veh in Median Storage, #	-	0	-	-	0	-	-	0	-	-	0	-
Grade, %	-	0	-	-	0	-	-	0	-	-	0	-
Peak Hour Factor	92	92	92	92	92	92	92	92	92	92	92	92
Heavy Vehicles, %	2	2	2	2	2	2	2	2	2	2	2	2
Mvmt Flow	0	0	67	20	0	0	24	21	7	0	58	0

Major/Minor	Minor2		Minor1		Major1			Major2				
Conflicting Flow All	131	134	58	165	131	25	58	0	0	28	0	0
Stage 1	58	58	-	73	73	-	-	-	-	-	-	-
Stage 2	73	76	-	92	58	-	-	-	-	-	-	-
Critical Hdwy	7.12	6.52	6.22	7.12	6.52	6.22	4.12	-	-	4.12	-	-
Critical Hdwy Stg 1	6.12	5.52	-	6.12	5.52	-	-	-	-	-	-	-
Critical Hdwy Stg 2	6.12	5.52	-	6.12	5.52	-	-	-	-	-	-	-
Follow-up Hdwy	3.518	4.018	3.318	3.518	4.018	3.318	2.218	-	-	2.218	-	-
Pot Cap-1 Maneuver	848	760	1008	805	763	1058	1546	-	-	1588	-	-
Stage 1	954	847	-	942	837	-	-	-	-	-	-	-
Stage 2	942	834	-	915	847	-	-	-	-	-	-	-
Platoon blocked, %	1	1		1	1	1		-	-	1	-	-
Mov Cap-1 Maneuver	838	748	1008	742	751	1058	1546	-	-	1588	-	-
Mov Cap-2 Maneuver	838	748	-	742	751	-	-	-	-	-	-	-
Stage 1	939	847	-	927	823	-	-	-	-	-	-	-
Stage 2	927	821	-	854	847	-	-	-	-	-	-	-

Approach	EB		WB		NB		SB	
HCM Control Delay, s	8.8		10		3.4		0	
HCM LOS	A		B					

Minor Lane/Major Mvmt	NBL	NBT	NBR	EBLn1WBLn1	SBL	SBT	SBR
Capacity (veh/h)	1546	-	-	1008	742	1588	-
HCM Lane V/C Ratio	0.015	-	-	0.067	0.026	-	-
HCM Control Delay (s)	7.4	-	-	8.8	10	0	-
HCM Lane LOS	A	-	-	A	B	A	-
HCM 95th %tile Q(veh)	0	-	-	0.2	0.1	0	-

Intersection												
Int Delay, s/veh	4.2											
Movement	EBL	EBT	EBR	WBL	WBT	WBR	NBL	NBT	NBR	SBL	SBT	SBR
Lane Configurations		↕			↕		↕	↕		↕	↕	
Traffic Vol, veh/h	0	0	43	12	0	0	73	63	21	0	37	0
Future Vol, veh/h	0	0	43	12	0	0	73	63	21	0	37	0
Conflicting Peds, #/hr	0	0	0	0	0	0	0	0	0	0	0	0
Sign Control	Stop	Stop	Stop	Stop	Stop	Stop	Free	Free	Free	Free	Free	Free
RT Channelized	-	-	None	-	-	None	-	-	None	-	-	None
Storage Length	-	-	-	-	-	-	0	-	-	0	-	-
Veh in Median Storage, #	-	0	-	-	0	-	-	0	-	-	0	-
Grade, %	-	0	-	-	0	-	-	0	-	-	0	-
Peak Hour Factor	92	92	92	92	92	92	92	92	92	92	92	92
Heavy Vehicles, %	2	2	2	2	2	2	2	2	2	2	2	2
Mvmt Flow	0	0	47	13	0	0	79	68	23	0	40	0

Major/Minor	Minor2		Minor1		Major1			Major2				
Conflicting Flow All	278	289	40	302	278	80	40	0	0	91	0	0
Stage 1	40	40	-	238	238	-	-	-	-	-	-	-
Stage 2	238	249	-	64	40	-	-	-	-	-	-	-
Critical Hdwy	7.12	6.52	6.22	7.12	6.52	6.22	4.12	-	-	4.12	-	-
Critical Hdwy Stg 1	6.12	5.52	-	6.12	5.52	-	-	-	-	-	-	-
Critical Hdwy Stg 2	6.12	5.52	-	6.12	5.52	-	-	-	-	-	-	-
Follow-up Hdwy	3.518	4.018	3.318	3.518	4.018	3.318	2.218	-	-	2.218	-	-
Pot Cap-1 Maneuver	695	633	1031	668	642	1008	1570	-	-	1514	-	-
Stage 1	975	862	-	780	715	-	-	-	-	-	-	-
Stage 2	780	707	-	947	862	-	-	-	-	-	-	-
Platoon blocked, %	1	1		1	1	1		-	-	1	-	-
Mov Cap-1 Maneuver	668	601	1031	614	610	1008	1570	-	-	1514	-	-
Mov Cap-2 Maneuver	668	601	-	614	610	-	-	-	-	-	-	-
Stage 1	926	862	-	741	679	-	-	-	-	-	-	-
Stage 2	740	672	-	904	862	-	-	-	-	-	-	-

Approach	EB		WB		NB		SB	
HCM Control Delay, s	8.7		11		3.4		0	
HCM LOS	A		B					

Minor Lane/Major Mvmt	NBL	NBT	NBR	EBLn1WBLn1	SBL	SBT	SBR
Capacity (veh/h)	1570	-	-	1031	614	1514	-
HCM Lane V/C Ratio	0.051	-	-	0.045	0.021	-	-
HCM Control Delay (s)	7.4	-	-	8.7	11	0	-
HCM Lane LOS	A	-	-	A	B	A	-
HCM 95th %tile Q(veh)	0.2	-	-	0.1	0.1	0	-

HCM 6th TWSC
6: Chapel Ridge Dr & North Access

2045 Total AM
09/06/2023

Intersection												
Int Delay, s/veh	4.9											
Movement	EBL	EBT	EBR	WBL	WBT	WBR	NBL	NBT	NBR	SBL	SBT	SBR
Lane Configurations		↕			↕		↕	↕		↕	↕	
Traffic Vol, veh/h	0	0	62	18	0	0	22	19	6	0	53	0
Future Vol, veh/h	0	0	62	18	0	0	22	19	6	0	53	0
Conflicting Peds, #/hr	0	0	0	0	0	0	0	0	0	0	0	0
Sign Control	Stop	Stop	Stop	Stop	Stop	Stop	Free	Free	Free	Free	Free	Free
RT Channelized	-	-	None	-	-	None	-	-	None	-	-	None
Storage Length	-	-	-	-	-	-	0	-	-	0	-	-
Veh in Median Storage, #	-	0	-	-	0	-	-	0	-	-	0	-
Grade, %	-	0	-	-	0	-	-	0	-	-	0	-
Peak Hour Factor	92	92	92	92	92	92	92	92	92	92	92	92
Heavy Vehicles, %	2	2	2	2	2	2	2	2	2	2	2	2
Mvmt Flow	0	0	67	20	0	0	24	21	7	0	58	0

Major/Minor	Minor2		Minor1		Major1			Major2				
Conflicting Flow All	131	134	58	165	131	25	58	0	0	28	0	0
Stage 1	58	58	-	73	73	-	-	-	-	-	-	-
Stage 2	73	76	-	92	58	-	-	-	-	-	-	-
Critical Hdwy	7.12	6.52	6.22	7.12	6.52	6.22	4.12	-	-	4.12	-	-
Critical Hdwy Stg 1	6.12	5.52	-	6.12	5.52	-	-	-	-	-	-	-
Critical Hdwy Stg 2	6.12	5.52	-	6.12	5.52	-	-	-	-	-	-	-
Follow-up Hdwy	3.518	4.018	3.318	3.518	4.018	3.318	2.218	-	-	2.218	-	-
Pot Cap-1 Maneuver	848	760	1008	805	763	1058	1546	-	-	1588	-	-
Stage 1	954	847	-	942	837	-	-	-	-	-	-	-
Stage 2	942	834	-	915	847	-	-	-	-	-	-	-
Platoon blocked, %	1	1		1	1	1		-	-	1	-	-
Mov Cap-1 Maneuver	838	748	1008	742	751	1058	1546	-	-	1588	-	-
Mov Cap-2 Maneuver	838	748	-	742	751	-	-	-	-	-	-	-
Stage 1	939	847	-	927	823	-	-	-	-	-	-	-
Stage 2	927	821	-	854	847	-	-	-	-	-	-	-

Approach	EB		WB		NB		SB	
HCM Control Delay, s	8.8		10		3.4		0	
HCM LOS	A		B					

Minor Lane/Major Mvmt	NBL	NBT	NBR	EBLn1WBLn1	SBL	SBT	SBR
Capacity (veh/h)	1546	-	-	1008	742	1588	-
HCM Lane V/C Ratio	0.015	-	-	0.067	0.026	-	-
HCM Control Delay (s)	7.4	-	-	8.8	10	0	-
HCM Lane LOS	A	-	-	A	B	A	-
HCM 95th %tile Q(veh)	0	-	-	0.2	0.1	0	-

Intersection												
Int Delay, s/veh	4.2											
Movement	EBL	EBT	EBR	WBL	WBT	WBR	NBL	NBT	NBR	SBL	SBT	SBR
Lane Configurations		↕			↕		↕	↕		↕	↕	
Traffic Vol, veh/h	0	0	43	12	0	0	73	63	21	0	37	0
Future Vol, veh/h	0	0	43	12	0	0	73	63	21	0	37	0
Conflicting Peds, #/hr	0	0	0	0	0	0	0	0	0	0	0	0
Sign Control	Stop	Stop	Stop	Stop	Stop	Stop	Free	Free	Free	Free	Free	Free
RT Channelized	-	-	None	-	-	None	-	-	None	-	-	None
Storage Length	-	-	-	-	-	-	0	-	-	0	-	-
Veh in Median Storage, #	-	0	-	-	0	-	-	0	-	-	0	-
Grade, %	-	0	-	-	0	-	-	0	-	-	0	-
Peak Hour Factor	92	92	92	92	92	92	92	92	92	92	92	92
Heavy Vehicles, %	2	2	2	2	2	2	2	2	2	2	2	2
Mvmt Flow	0	0	47	13	0	0	79	68	23	0	40	0

Major/Minor	Minor2		Minor1		Major1			Major2				
Conflicting Flow All	278	289	40	302	278	80	40	0	0	91	0	0
Stage 1	40	40	-	238	238	-	-	-	-	-	-	-
Stage 2	238	249	-	64	40	-	-	-	-	-	-	-
Critical Hdwy	7.12	6.52	6.22	7.12	6.52	6.22	4.12	-	-	4.12	-	-
Critical Hdwy Stg 1	6.12	5.52	-	6.12	5.52	-	-	-	-	-	-	-
Critical Hdwy Stg 2	6.12	5.52	-	6.12	5.52	-	-	-	-	-	-	-
Follow-up Hdwy	3.518	4.018	3.318	3.518	4.018	3.318	2.218	-	-	2.218	-	-
Pot Cap-1 Maneuver	695	633	1031	668	642	1008	1570	-	-	1514	-	-
Stage 1	975	862	-	780	715	-	-	-	-	-	-	-
Stage 2	780	707	-	947	862	-	-	-	-	-	-	-
Platoon blocked, %	1	1		1	1	1		-	-	1	-	-
Mov Cap-1 Maneuver	668	601	1031	614	610	1008	1570	-	-	1514	-	-
Mov Cap-2 Maneuver	668	601	-	614	610	-	-	-	-	-	-	-
Stage 1	926	862	-	741	679	-	-	-	-	-	-	-
Stage 2	740	672	-	904	862	-	-	-	-	-	-	-

Approach	EB		WB		NB		SB	
HCM Control Delay, s	8.7		11		3.4		0	
HCM LOS	A		B					

Minor Lane/Major Mvmt	NBL	NBT	NBR	EBLn1WBLn1	SBL	SBT	SBR
Capacity (veh/h)	1570	-	-	1031	614	1514	-
HCM Lane V/C Ratio	0.051	-	-	0.045	0.021	-	-
HCM Control Delay (s)	7.4	-	-	8.7	11	0	-
HCM Lane LOS	A	-	-	A	B	A	-
HCM 95th %tile Q(veh)	0.2	-	-	0.1	0.1	0	-

Intersection						
Int Delay, s/veh	1.8					
Movement	WBL	WBR	NBT	NBR	SBL	SBT
Lane Configurations	↔		↔		↔	↔
Traffic Vol, veh/h	44	0	47	16	0	132
Future Vol, veh/h	44	0	47	16	0	132
Conflicting Peds, #/hr	0	0	0	0	0	0
Sign Control	Stop	Stop	Free	Free	Free	Free
RT Channelized	-	None	-	None	-	None
Storage Length	0	-	-	-	0	-
Veh in Median Storage, #	0	-	0	-	-	0
Grade, %	0	-	0	-	-	0
Peak Hour Factor	92	92	92	92	92	92
Heavy Vehicles, %	2	2	2	2	2	2
Mvmt Flow	48	0	51	17	0	143

Major/Minor	Minor1	Major1	Major2		
Conflicting Flow All	203	60	0	0	68
Stage 1	60	-	-	-	-
Stage 2	143	-	-	-	-
Critical Hdwy	6.42	6.22	-	-	4.12
Critical Hdwy Stg 1	5.42	-	-	-	-
Critical Hdwy Stg 2	5.42	-	-	-	-
Follow-up Hdwy	3.518	3.318	-	-	2.218
Pot Cap-1 Maneuver	789	1012	-	-	1536
Stage 1	966	-	-	-	-
Stage 2	884	-	-	-	-
Platoon blocked, %	1	1	-	-	1
Mov Cap-1 Maneuver	789	1012	-	-	1536
Mov Cap-2 Maneuver	789	-	-	-	-
Stage 1	966	-	-	-	-
Stage 2	884	-	-	-	-

Approach	WB	NB	SB
HCM Control Delay, s	9.9	0	0
HCM LOS	A		

Minor Lane/Major Mvmt	NBT	NBRWBLn1	SBL	SBT
Capacity (veh/h)	-	-	789	1536
HCM Lane V/C Ratio	-	-	0.061	-
HCM Control Delay (s)	-	-	9.9	0
HCM Lane LOS	-	-	A	A
HCM 95th %tile Q(veh)	-	-	0.2	0

HCM 6th TWSC
7: Chapel Ridge Dr & South Access

2025 Total PM
09/06/2023

Intersection						
Int Delay, s/veh	0.9					
Movement	WBL	WBR	NBT	NBR	SBL	SBT
Lane Configurations						
Traffic Vol, veh/h	31	0	157	52	0	92
Future Vol, veh/h	31	0	157	52	0	92
Conflicting Peds, #/hr	0	0	0	0	0	0
Sign Control	Stop	Stop	Free	Free	Free	Free
RT Channelized	-	None	-	None	-	None
Storage Length	0	-	-	-	0	-
Veh in Median Storage, #	0	-	0	-	-	0
Grade, %	0	-	0	-	-	0
Peak Hour Factor	92	92	92	92	92	92
Heavy Vehicles, %	2	2	2	2	2	2
Mvmt Flow	34	0	171	57	0	100

Major/Minor	Minor1	Major1	Major2		
Conflicting Flow All	300	200	0	0	228
Stage 1	200	-	-	-	-
Stage 2	100	-	-	-	-
Critical Hdwy	6.42	6.22	-	-	4.12
Critical Hdwy Stg 1	5.42	-	-	-	-
Critical Hdwy Stg 2	5.42	-	-	-	-
Follow-up Hdwy	3.518	3.318	-	-	2.218
Pot Cap-1 Maneuver	747	917	-	-	1361
Stage 1	874	-	-	-	-
Stage 2	924	-	-	-	-
Platoon blocked, %	1	1	-	-	1
Mov Cap-1 Maneuver	747	917	-	-	1361
Mov Cap-2 Maneuver	747	-	-	-	-
Stage 1	874	-	-	-	-
Stage 2	924	-	-	-	-

Approach	WB	NB	SB
HCM Control Delay, s	10	0	0
HCM LOS	B		

Minor Lane/Major Mvmt	NBT	NBRWBLn1	SBL	SBT
Capacity (veh/h)	-	-	747	1361
HCM Lane V/C Ratio	-	-	0.045	-
HCM Control Delay (s)	-	-	10	0
HCM Lane LOS	-	-	B	A
HCM 95th %tile Q(veh)	-	-	0.1	0

HCM 6th TWSC
7: Chapel Ridge Dr & South Access

2045 Total AM
09/06/2023

Intersection						
Int Delay, s/veh	1.8					
Movement	WBL	WBR	NBT	NBR	SBL	SBT
Lane Configurations	↔		↔		↔	↔
Traffic Vol, veh/h	44	0	47	16	0	132
Future Vol, veh/h	44	0	47	16	0	132
Conflicting Peds, #/hr	0	0	0	0	0	0
Sign Control	Stop	Stop	Free	Free	Free	Free
RT Channelized	-	None	-	None	-	None
Storage Length	0	-	-	-	0	-
Veh in Median Storage, #	0	-	0	-	-	0
Grade, %	0	-	0	-	-	0
Peak Hour Factor	92	92	92	92	92	92
Heavy Vehicles, %	2	2	2	2	2	2
Mvmt Flow	48	0	51	17	0	143

Major/Minor	Minor1	Major1	Major2		
Conflicting Flow All	203	60	0	0	68
Stage 1	60	-	-	-	-
Stage 2	143	-	-	-	-
Critical Hdwy	6.42	6.22	-	-	4.12
Critical Hdwy Stg 1	5.42	-	-	-	-
Critical Hdwy Stg 2	5.42	-	-	-	-
Follow-up Hdwy	3.518	3.318	-	-	2.218
Pot Cap-1 Maneuver	789	1012	-	-	1536
Stage 1	966	-	-	-	-
Stage 2	884	-	-	-	-
Platoon blocked, %	1	1	-	-	1
Mov Cap-1 Maneuver	789	1012	-	-	1536
Mov Cap-2 Maneuver	789	-	-	-	-
Stage 1	966	-	-	-	-
Stage 2	884	-	-	-	-

Approach	WB	NB	SB
HCM Control Delay, s	9.9	0	0
HCM LOS	A		

Minor Lane/Major Mvmt	NBT	NBRWBLn1	SBL	SBT
Capacity (veh/h)	-	-	789	1536
HCM Lane V/C Ratio	-	-	0.061	-
HCM Control Delay (s)	-	-	9.9	0
HCM Lane LOS	-	-	A	A
HCM 95th %tile Q(veh)	-	-	0.2	0

Intersection						
Int Delay, s/veh	0.9					
Movement	WBL	WBR	NBT	NBR	SBL	SBT
Lane Configurations						
Traffic Vol, veh/h	31	0	157	52	0	92
Future Vol, veh/h	31	0	157	52	0	92
Conflicting Peds, #/hr	0	0	0	0	0	0
Sign Control	Stop	Stop	Free	Free	Free	Free
RT Channelized	-	None	-	None	-	None
Storage Length	0	-	-	-	0	-
Veh in Median Storage, #	0	-	0	-	-	0
Grade, %	0	-	0	-	-	0
Peak Hour Factor	92	92	92	92	92	92
Heavy Vehicles, %	2	2	2	2	2	2
Mvmt Flow	34	0	171	57	0	100

Major/Minor	Minor1	Major1	Major2		
Conflicting Flow All	300	200	0	0	228
Stage 1	200	-	-	-	-
Stage 2	100	-	-	-	-
Critical Hdwy	6.42	6.22	-	-	4.12
Critical Hdwy Stg 1	5.42	-	-	-	-
Critical Hdwy Stg 2	5.42	-	-	-	-
Follow-up Hdwy	3.518	3.318	-	-	2.218
Pot Cap-1 Maneuver	747	917	-	-	1361
Stage 1	874	-	-	-	-
Stage 2	924	-	-	-	-
Platoon blocked, %	1	1	-	-	1
Mov Cap-1 Maneuver	747	917	-	-	1361
Mov Cap-2 Maneuver	747	-	-	-	-
Stage 1	874	-	-	-	-
Stage 2	924	-	-	-	-

Approach	WB	NB	SB
HCM Control Delay, s	10	0	0
HCM LOS	B		

Minor Lane/Major Mvmt	NBT	NBRWBLn1	SBL	SBT
Capacity (veh/h)	-	-	747	1361
HCM Lane V/C Ratio	-	-	0.045	-
HCM Control Delay (s)	-	-	10	0
HCM Lane LOS	-	-	B	A
HCM 95th %tile Q(veh)	-	-	0.1	0

APPENDIX E

Signal Timing Worksheets

Intersection 395 at Voyager Pkwy and Old Ranch Rd - Timing table, page 1

Page 1	Phases											
	1	2	3	4	5	6	7	8	9	10	11	12
Min Green	4	23	0	4	4	23	0	4	0	0	0	0
Passage Time I	2.0	3.0	0.0	2.0	2.0	3.0	0.0	2.0	0.0	0.0	0.0	0.0
Passage Time II	0.0	0.0	0.0	0.0	0.0	0.0	0.0	0.0	0.0	0.0	0.0	0.0
Max Green I	12	30	0	25	12	30	0	25	0	0	0	0
Max Green II	0	0	0	0	0	0	0	0	0	0	0	0
Yellow Clearance	3.0	5.5	0.0	4.5	3.0	5.5	0.0	4.5	0.0	0.0	0.0	0.0
Red Clearance	2.0	2.0	0.0	2.0	2.0	2.0	0.0	2.0	0.0	0.0	0.0	0.0
Added Initial	0.0	0.0	0.0	0.0	0.0	0.0	0.0	0.0	0.0	0.0	0.0	0.0
Max Added Initial	0	0	0	0	0	0	0	0	0	0	0	0
Time Before Reduction	0	0	0	0	0	0	0	0	0	0	0	0
Cars Before Reduction	0	0	0	0	0	0	0	0	0	0	0	0
Time To Reduce	0	0	0	0	0	0	0	0	0	0	0	0
Min Passage	0.0	0.0	0.0	0.0	0.0	0.0	0.0	0.0	0.0	0.0	0.0	0.0
Recall Green Time	0	0	0	0	0	0	0	0	0	0	0	0
Red Revert Time	5.0	5.0	0.0	5.0	5.0	5.0	0.0	5.0	0.0	0.0	0.0	0.0
Walk Time	0	7	0	0	0	7	0	7	0	0	0	0
Pedestrian Clearance	0	16	0	0	0	16	0	39	0	0	0	0
Handicap Walk	0	0	0	0	0	0	0	0	0	0	0	0
Handicap Ped Clearance	0	0	0	0	0	0	0	0	0	0	0	0
Voyager Pkwy	X	X			X	X						
Old Ranch Rd				X				X				
Compass Direction	S	N		E	N	S		W				
Through, Turn or XPed	Left,prt	Thru		Thru	Left,prt	Thru		Thru				

Intersection 395 at Voyager Pkwy and Old Ranch Rd - Sequence table, page 1

Page 1	Ring 1 Phases				Ring 2 Phases				Ring 3 Phases			
	1	2	3	4	5	6	7	8	9	10	11	12
State 1	Vehicle				Vehicle							
Barrier 1												
State 2		V & P				V & P						
Barrier 2	XXXXXXXXXXXXXXXXXXXXXXXXXX				XXXXXXXXXXXXXXXXXXXXXXXXXX							
State 3				Vehicle				V & P				
Barrier 3	XXXXXXXXXXXXXXXXXXXXXXXXXX				XXXXXXXXXXXXXXXXXXXXXXXXXX							
State 4												
Barrier 4												
State 5												
Barrier 5												
State 6												
Barrier 6												
State 7												
Barrier 7												
State 8												
Barrier 8												
State 9												
Barrier 9												
State 10												
Barrier 10												
State 11												
Barrier 11												
State 12												
Barrier 12												

Intersection 395 at Voyager Pkwy and Old Ranch Rd - Phases control table, page 1

Page 1	Vehicle Phases		Ped Phases
	_____111 123456789012		_____111 123456789012
Min Recalls		Ped Recalls	
Max Recalls	2 6	Handicap Ped Recalls	
Recall If Maxed		Soft Ped Recalls	
Dual Entry	4 8	Do Not Recall Ped	2 4 6 8
Do Not Skip		Allow Walk Reduction	
Simultaneous Gap Out		Hold In Walk	
Restricted Phases		Allow Ped Re-service	
Sequential Initial Timing		Rest In Walk	No
Max Timer Starts For Call			
Reduction Starts For Call			
Red To Avoid Left Turn Trap			
Rest In Red	No		

Intersection 395 at Voyager Pkwy and Old Ranch Rd - Spec signaling cntrl tbl, pg 1

Page 1							
Signaling Control 1				Signaling Control 2			
Function	Flashing permissive left turn	Timer 1	2.0	Function	Flashing permissive left turn	Timer 1	2.0
Operand	0	Timer 2	0.0	Operand	0	Timer 2	0.0
Trigger	Always enabled	Timer 3	0.0	Trigger	Always enabled	Timer 3	0.0
	111	Output 1	25		111	Output 1	1
	123456789012	Output 2	34		123456789012	Output 2	35
Phases 1	5	Output 3	41	Phases 1	1	Output 3	40
Phases 2	2 6	Output 4	1	Phases 2	2 6	Output 4	1
Overlaps 1				Overlaps 1			
Overlaps 2				Overlaps 2			
Signaling Control 3				Signaling Control 4			
Function	None	Timer 1	0.0	Function	None	Timer 1	0.0
Operand	0	Timer 2	0.0	Operand	0	Timer 2	0.0
Trigger	Always enabled	Timer 3	0.0	Trigger	Always enabled	Timer 3	0.0
	111	Output 1	1		111	Output 1	1
	123456789012	Output 2	1		123456789012	Output 2	1
Phases 1		Output 3	1	Phases 1		Output 3	1
Phases 2		Output 4	1	Phases 2		Output 4	1
Overlaps 1				Overlaps 1			
Overlaps 2				Overlaps 2			

Intersection 395 at Voyager Pkwy and Old Ranch Rd - Schedule table, events 1-25

Event Num	Ena- bled	Event Type	Event Parameters		Start					Duration Minutes	Stop		Repetition		Priority
			Param 1	Param 2	Mon	Day	Hour	Min	Sec		Mon	Day	Repeat	Intervals	
1															
2															
3	Yes	Run Plan	Plan 6	Ofst #1	1	1	06	30	00	720	12	31	Weekly	MTWTF	Low
4															
5															
6															
7															
8															
9															
10															
11															
12															
13															
14															
15															
16															
17															
18															
19															
20															
21															
22															
23															
24															
25															

Intersection 395 at Voyager Pkwy and Old Ranch Rd - Coordination table, plans 5-6

Plan 5	111	Cycle Length	138	Phases	Splits	Alternate Mins	Alternate Passages	Alternate Maxes
	123456789012	Offset 1	44					
Coordinated Phases		Offset 2	0	1	16	0	0.0	16
	2 6	Offset 3	0	2	85	0	0.0	99
Secondary Coordinated Phases		Offset 4	0	3	0	0	0.0	0
		Relative Secondary Offset	0	4	37	0	0.0	40
Extra Time Phases		Permissive Period	Auto	5	16	0	0.0	16
		Max Cycle Addition	34	6	85	0	0.0	99
Additional Max Recalls		Max Cycle Subtraction	34	7	0	0	0.0	0
		Coord Actuated Period	0	8	37	0	0.0	40
Units	Seconds	Top Of Cycle Green Point	End	9	0	0	0.0	0
		Big Bang Preempt Recvry	No	10	0	0	0.0	0
		Big Bang Ped Recovery	No	11	0	0	0.0	0
		Min Lagging Left Split	0%	12	0	0	0.0	0
Plan 6	111	Cycle Length	69	Phases	Splits	Alternate Mins	Alternate Passages	Alternate Maxes
	123456789012	Offset 1	26					
Coordinated Phases		Offset 2	0	1	13	0	0.0	12
	2 6	Offset 3	0	2	31	14	0.0	31
Secondary Coordinated Phases		Offset 4	0	3	0	0	0.0	0
		Relative Secondary Offset	0	4	25	0	0.0	25
Extra Time Phases		Permissive Period	Auto	5	13	0	0.0	12
		Max Cycle Addition	17	6	31	14	0.0	31
Additional Max Recalls		Max Cycle Subtraction	17	7	0	0	0.0	0
		Coord Actuated Period	0	8	25	0	0.0	25
Units	Seconds	Top Of Cycle Green Point	End	9	0	0	0.0	0
		Big Bang Preempt Recvry	No	10	0	0	0.0	0
		Big Bang Ped Recovery	No	11	0	0	0.0	0
		Min Lagging Left Split	0%	12	0	0	0.0	0

Intersection 537 at Old Ranch Rd and Powers Blvd Northbound - Timing table, page 1

Page 1	Phases											
	1	2	3	4	5	6	7	8	9	10	11	12
Min Green	0	6	0	12	0	0	4	12	0	0	0	0
Passage Time I	0.0	3.0	0.0	2.0	0.0	0.0	1.0	2.0	0.0	0.0	0.0	0.0
Passage Time II	0.0	0.0	0.0	0.0	0.0	0.0	0.0	0.0	0.0	0.0	0.0	0.0
Max Green I	0	20	0	40	0	0	8	40	0	0	0	0
Max Green II	0	0	0	0	0	0	0	0	0	0	0	0
Yellow Clearance	0.0	4.5	0.0	4.0	0.0	0.0	4.0	4.0	0.0	0.0	0.0	0.0
Red Clearance	0.0	2.0	0.0	2.0	0.0	0.0	2.0	2.0	0.0	0.0	0.0	0.0
Added Initial	0.0	0.0	0.0	0.0	0.0	0.0	0.0	0.0	0.0	0.0	0.0	0.0
Max Added Initial	0	0	0	0	0	0	0	0	0	0	0	0
Time Before Reduction	0	0	0	0	0	0	0	0	0	0	0	0
Cars Before Reduction	0	0	0	0	0	0	0	0	0	0	0	0
Time To Reduce	0	0	0	0	0	0	0	0	0	0	0	0
Min Passage	0.0	0.0	0.0	0.0	0.0	0.0	0.0	0.0	0.0	0.0	0.0	0.0
Recall Green Time	0	0	0	0	0	0	0	0	0	0	0	0
Red Revert Time	0.0	0.0	0.0	0.0	0.0	0.0	0.0	0.0	0.0	0.0	0.0	0.0
Walk Time	0	7	0	7	0	0	0	7	0	0	0	0
Pedestrian Clearance	0	25	0	11	0	0	0	11	0	0	0	0
Handicap Walk	0	0	0	0	0	0	0	0	0	0	0	0
Handicap Ped Clearance	0	0	0	0	0	0	0	0	0	0	0	0
Old Ranch Rd				X			X	X				
Powers Blvd Northbound		X										
Compass Direction		NW		NE			NE	SW				
Through, Turn or XPed		Thru		Thru			Left.p/p	Thru				

Intersection 537 at Old Ranch Rd and Powers Blvd Northbound - Sequence table, page 1

Page 1	Ring 1 Phases				Ring 2 Phases				Ring 3 Phases			
	1	2	3	4	5	6	7	8	9	10	11	12
State 1		V & P										
Barrier 1	XXXXXXXXXXXXXXXXXXXXXXXXXX				XXXXXXXXXXXXXXXXXXXXXXXXXX							
State 2								V & P				
Barrier 2												
State 3			V & P			Vehicle						
Barrier 3	XXXXXXXXXXXXXXXXXXXXXXXXXX				XXXXXXXXXXXXXXXXXXXXXXXXXX							
State 4												
Barrier 4												
State 5												
Barrier 5												
State 6												
Barrier 6												
State 7												
Barrier 7												
State 8												
Barrier 8												
State 9												
Barrier 9												
State 10												
Barrier 10												
State 11												
Barrier 11												
State 12												
Barrier 12												

Intersection 537 at Old Ranch Rd and Powers Blvd Northbound - Phases control table, page 1

Page 1	Vehicle Phases		Ped Phases
	_____111 123456789012		_____111 123456789012
Min Recalls		Ped Recalls	
Max Recalls	4 8	Handicap Ped Recalls	
Recall If Maxed		Soft Ped Recalls	
Dual Entry		Do Not Recall Ped	2 4 6 8
Do Not Skip		Allow Walk Reduction	
Simultaneous Gap Out		Hold In Walk	
Restricted Phases		Allow Ped Re-service	4 8
Sequential Initial Timing		Rest In Walk	No
Max Timer Starts For Call			
Reduction Starts For Call			
Red To Avoid Left Turn Trap			
Rest In Red	No		

Intersection 537 at Old Ranch Rd and Powers Blvd Northbound - Schedule table, events 1-25

Event Num	Enabled	Event Type	Event Parameters		Start					Duration Minutes	Stop		Repetition		Priority
			Param 1	Param 2	Mon	Day	Hour	Min	Sec		Mon	Day	Repeat	Intervals	
1	Yes	Run Plan	Plan 3	Ofst #1	1	1	08	30	00	360	12	31	Weekly	MTWTF	Low
2	Yes	Run Plan	Plan 1	Ofst #1	1	1	06	30	00	120	12	31	Weekly	MTWTF	Low
3	Yes	Run Plan	Plan 1	Ofst #1	1	1	14	30	00	210	12	31	Weekly	MTWTF	Low
4	Yes	Run Plan	Plan 4	Ofst #1	1	1	18	00	00	180	12	31	Weekly	MTWTF	Low
5	No	Run Plan	Plan 3	Ofst #1	1	1	21	00	00	180	12	31	Weekly	MTWTF	Low
6	No	Run Plan	Plan 3	Ofst #1	1	1	00	00	00	420	12	31	Weekly	S S	Low
7	Yes	Run Plan	Plan 4	Ofst #1	1	1	07	00	00	840	12	31	Weekly	S S	Low
8	No	Run Plan	Plan 3	Ofst #1	1	1	21	00	00	180	12	31	Weekly	S S	Low
9															
10															
11															
12															
13															
14															
15															
16															
17															
18															
19															
20															
21															
22															
23															
24															
25															

Intersection 537 at Old Ranch Rd and Powers Blvd Northbound - Coordination table, plans 1-2

Plan 1	111	Cycle Length	114	Phases	Splits	Alternate Mins	Alternate Passages	Alternate Maxes
	123456789012	Offset 1	56					
Coordinated Phases	4 8	Offset 2	0	1	0	0	0.0	0
		Offset 3	0	2	20	6	0.0	18
Secondary Coordinated Phases		Offset 4	0	3	0	0	0.0	0
		Relative Secondary Offset	0	4	94	0	0.0	112
Extra Time Phases		Permissive Period	Auto	5	0	0	0.0	0
		Max Cycle Addition	28	6	0	0	0.0	0
Additional Max Recalls		Max Cycle Subtraction	28	7	18	0	0.0	17
		Coord Actuated Period	0	8	76	0	0.0	90
Units	Seconds	Top Of Cycle Green Point	End	9	0	0	0.0	0
		Big Bang Preempt Recvry	No	10	0	0	0.0	0
		Big Bang Ped Recovery	No	11	0	0	0.0	0
		Min Lagging Left Split	0%	12	0	0	0.0	0
Plan 2	111	Cycle Length	114	Phases	Splits	Alternate Mins	Alternate Passages	Alternate Maxes
	123456789012	Offset 1	56					
Coordinated Phases	4 8	Offset 2	0	1	0	0	0.0	0
		Offset 3	0	2	28	12	0.0	28
Secondary Coordinated Phases		Offset 4	0	3	0	0	0.0	0
		Relative Secondary Offset	0	4	86	0	0.0	102
Extra Time Phases		Permissive Period	Auto	5	0	0	0.0	0
		Max Cycle Addition	28	6	0	0	0.0	0
Additional Max Recalls		Max Cycle Subtraction	28	7	23	0	0.0	23
		Coord Actuated Period	0	8	63	0	0.0	73
Units	Seconds	Top Of Cycle Green Point	End	9	0	0	0.0	0
		Big Bang Preempt Recvry	No	10	0	0	0.0	0
		Big Bang Ped Recovery	No	11	0	0	0.0	0
		Min Lagging Left Split	0%	12	0	0	0.0	0

Intersection 537 at Old Ranch Rd and Powers Blvd Northbound - Coordination table, plans 3-4

Plan 3	111	Cycle Length	94	Phases	Splits	Alternate Mins	Alternate Passages	Alternate Maxes
	123456789012	Offset 1	79					
Coordinated Phases	4 8	Offset 2	0	1	0	0	0.0	0
		Offset 3	0	2	24	9	0.0	23
Secondary Coordinated Phases		Offset 4	0	3	0	0	0.0	0
		Relative Secondary Offset	0	4	70	0	0.0	82
Extra Time Phases		Permissive Period	Auto	5	0	0	0.0	0
		Max Cycle Addition	23	6	0	0	0.0	0
Additional Max Recalls		Max Cycle Subtraction	23	7	15	0	0.0	13
		Coord Actuated Period	0	8	55	0	0.0	63
Units	Seconds	Top Of Cycle Green Point	End	9	0	0	0.0	0
		Big Bang Preempt Recvry	No	10	0	0	0.0	0
		Big Bang Ped Recovery	No	11	0	0	0.0	0
		Min Lagging Left Split	0%	12	0	0	0.0	0
Plan 4	111	Cycle Length	75	Phases	Splits	Alternate Mins	Alternate Passages	Alternate Maxes
	123456789012	Offset 1	61					
Coordinated Phases	4 8	Offset 2	0	1	0	0	0.0	0
		Offset 3	0	2	29	0	0.0	30
Secondary Coordinated Phases		Offset 4	0	3	0	0	0.0	0
		Relative Secondary Offset	0	4	46	0	0.0	52
Extra Time Phases		Permissive Period	Auto	5	0	0	0.0	0
		Max Cycle Addition	18	6	0	0	0.0	0
Additional Max Recalls		Max Cycle Subtraction	18	7	16	0	0.0	15
		Coord Actuated Period	0	8	30	0	0.0	32
Units	Seconds	Top Of Cycle Green Point	End	9	0	0	0.0	0
		Big Bang Preempt Recvry	No	10	0	0	0.0	0
		Big Bang Ped Recovery	No	11	0	0	0.0	0
		Min Lagging Left Split	0%	12	0	0	0.0	0

Intersection 538 at Old Ranch Rd and Powers Blvd Southbound - Timing table, page 1

Page 1	Phases											
	1	2	3	4	5	6	7	8	9	10	11	12
Min Green	0	0	4	15	0	6	0	15	0	0	0	0
Passage Time I	0.0	0.0	1.0	2.0	0.0	3.0	0.0	2.0	0.0	0.0	0.0	0.0
Passage Time II	0.0	0.0	0.0	0.0	0.0	0.0	0.0	0.0	0.0	0.0	0.0	0.0
Max Green I	0	0	8	40	0	20	0	40	0	0	0	0
Max Green II	0	0	0	0	0	0	0	0	0	0	0	0
Yellow Clearance	0.0	0.0	4.0	4.0	0.0	4.5	0.0	4.0	0.0	0.0	0.0	0.0
Red Clearance	0.0	0.0	2.0	2.0	0.0	2.0	0.0	2.0	0.0	0.0	0.0	0.0
Added Initial	0.0	0.0	0.0	0.0	0.0	0.0	0.0	0.0	0.0	0.0	0.0	0.0
Max Added Initial	0	0	0	0	0	0	0	0	0	0	0	0
Time Before Reduction	0	0	0	0	0	0	0	0	0	0	0	0
Cars Before Reduction	0	0	0	0	0	0	0	0	0	0	0	0
Time To Reduce	0	0	0	0	0	0	0	0	0	0	0	0
Min Passage	0.0	0.0	0.0	0.0	0.0	0.0	0.0	0.0	0.0	0.0	0.0	0.0
Recall Green Time	0	0	0	0	0	0	0	0	0	0	0	0
Red Revert Time	0.0	0.0	0.0	0.0	0.0	0.0	0.0	0.0	0.0	0.0	0.0	0.0
Walk Time	0	0	0	7	0	7	0	7	0	0	0	0
Pedestrian Clearance	0	0	0	11	0	25	0	11	0	0	0	0
Handicap Walk	0	0	0	0	0	0	0	0	0	0	0	0
Handicap Ped Clearance	0	0	0	0	0	0	0	0	0	0	0	0
Old Ranch Rd			X	X				X				
Powers Blvd Southbound						X						
Compass Direction			SW	NE		SE		SW				
Through, Turn or XPed			Left,p/p	Thru		Thru		Thru				

Intersection 538 at Old Ranch Rd and Powers Blvd Southbound - Sequence table, page 1

Page 1	Ring 1 Phases				Ring 2 Phases				Ring 3 Phases			
	1	2	3	4	5	6	7	8	9	10	11	12
State 1						V & P						
Barrier 1	XXXXXXXXXXXXXXXXXXXXXXXXXXXX				XXXXXXXXXXXXXXXXXXXXXXXXXXXX							
State 2				V & P								
Barrier 2												
State 3			Vehicle					V & P				
Barrier 3	XXXXXXXXXXXXXXXXXXXXXXXXXXXX				XXXXXXXXXXXXXXXXXXXXXXXXXXXX							
State 4												
Barrier 4												
State 5												
Barrier 5												
State 6												
Barrier 6												
State 7												
Barrier 7												
State 8												
Barrier 8												
State 9												
Barrier 9												
State 10												
Barrier 10												
State 11												
Barrier 11												
State 12												
Barrier 12												

Intersection 538 at Old Ranch Rd and Powers Blvd Southbound - Phases control table, page 1

Page 1	Vehicle Phases		Ped Phases
	_____111 123456789012		_____111 123456789012
Min Recalls		Ped Recalls	
Max Recalls	4 8	Handicap Ped Recalls	
Recall If Maxed		Soft Ped Recalls	
Dual Entry		Do Not Recall Ped	2 4 6 8
Do Not Skip		Allow Walk Reduction	
Simultaneous Gap Out		Hold In Walk	
Restricted Phases		Allow Ped Re-service	4 8
Sequential Initial Timing		Rest In Walk	No
Max Timer Starts For Call			
Reduction Starts For Call			
Red To Avoid Left Turn Trap			
Rest In Red	No		

Intersection 538 at Old Ranch Rd and Powers Blvd Southbound - Schedule table, events 1-25

Event Num	Enabled	Event Type	Event Parameters		Start					Duration Minutes	Stop		Repetition		Priority
			Param 1	Param 2	Mon	Day	Hour	Min	Sec		Mon	Day	Repeat	Intervals	
1	Yes	Run Plan	Plan 3	Ofst #1	1	1	08	30	00	360	12	31	Weekly	MTWTF	Low
2	Yes	Run Plan	Plan 1	Ofst #1	1	1	06	30	00	120	12	31	Weekly	MTWTF	Low
3	Yes	Run Plan	Plan 1	Ofst #1	1	1	14	30	00	210	12	31	Weekly	MTWTF	Low
4	Yes	Run Plan	Plan 4	Ofst #1	1	1	18	00	00	180	12	31	Weekly	MTWTF	Low
5	No	Run Plan	Plan 3	Ofst #1	1	1	21	00	00	180	12	31	Weekly	MTWTF	Low
6	No	Run Plan	Plan 3	Ofst #1	1	1	00	00	00	420	12	31	Weekly	S S	Low
7	Yes	Run Plan	Plan 4	Ofst #1	1	1	07	00	00	840	12	31	Weekly	S S	Low
8	No	Run Plan	Plan 3	Ofst #1	1	1	21	00	00	180	12	31	Weekly	S S	Low
9															
10															
11															
12															
13															
14															
15															
16															
17															
18															
19															
20															
21															
22															
23															
24															
25															

Intersection 538 at Old Ranch Rd and Powers Blvd Southbound - Coordination table, plans 1-2

Plan 1	111	Cycle Length	114	Phases	Splits	Alternate Mins	Alternate Passages	Alternate Maxes
	123456789012	Offset 1	56					
Coordinated Phases	4 8	Offset 2	0	1	0	0	0.0	0
		Offset 3	0	2	0	0	0.0	0
Secondary Coordinated Phases		Offset 4	0	3	16	0	0.0	15
		Relative Secondary Offset	0	4	70	0	0.0	82
Extra Time Phases		Permissive Period	Auto	5	0	0	0.0	0
		Max Cycle Addition	28	6	28	6	0.0	28
Additional Max Recalls		Max Cycle Subtraction	28	7	0	0	0.0	0
		Coord Actuated Period	0	8	86	0	0.0	102
Units	Seconds	Top Of Cycle Green Point	End	9	0	0	0.0	0
		Big Bang Preempt Recvry	No	10	0	0	0.0	0
		Big Bang Ped Recovery	No	11	0	0	0.0	0
		Min Lagging Left Split	0%	12	0	0	0.0	0
Plan 2	111	Cycle Length	114	Phases	Splits	Alternate Mins	Alternate Passages	Alternate Maxes
	123456789012	Offset 1	56					
Coordinated Phases	4 8	Offset 2	0	1	0	0	0.0	0
		Offset 3	0	2	0	0	0.0	0
Secondary Coordinated Phases		Offset 4	0	3	33	0	0.0	36
		Relative Secondary Offset	0	4	61	0	0.0	71
Extra Time Phases		Permissive Period	Auto	5	0	0	0.0	0
		Max Cycle Addition	28	6	20	6	0.0	18
Additional Max Recalls		Max Cycle Subtraction	28	7	0	0	0.0	0
		Coord Actuated Period	0	8	94	0	0.0	112
Units	Seconds	Top Of Cycle Green Point	End	9	0	0	0.0	0
		Big Bang Preempt Recvry	No	10	0	0	0.0	0
		Big Bang Ped Recovery	No	11	0	0	0.0	0
		Min Lagging Left Split	0%	12	0	0	0.0	0

Intersection 538 at Old Ranch Rd and Powers Blvd Southbound - Coordination table, plans 3-4

Plan 3	111	Cycle Length	94	Phases	Splits	Alternate Mins	Alternate Passages	Alternate Maxes
	123456789012	Offset 1	79					
Coordinated Phases	4 8	Offset 2	0	1	0	0	0.0	0
		Offset 3	0	2	0	0	0.0	0
Secondary Coordinated Phases		Offset 4	0	3	15	0	0.0	13
		Relative Secondary Offset	0	4	56	0	0.0	65
Extra Time Phases		Permissive Period	Auto	5	0	0	0.0	0
		Max Cycle Addition	23	6	23	8	0.0	21
Additional Max Recalls		Max Cycle Subtraction	23	7	0	0	0.0	0
		Coord Actuated Period	0	8	71	0	0.0	83
Units	Seconds	Top Of Cycle Green Point	End	9	0	0	0.0	0
		Big Bang Preempt Recvry	No	10	0	0	0.0	0
		Big Bang Ped Recovery	No	11	0	0	0.0	0
		Min Lagging Left Split	0%	12	0	0	0.0	0
Plan 4	111	Cycle Length	75	Phases	Splits	Alternate Mins	Alternate Passages	Alternate Maxes
	123456789012	Offset 1	53					
Coordinated Phases	4 8	Offset 2	0	1	0	0	0.0	0
		Offset 3	0	2	0	0	0.0	0
Secondary Coordinated Phases		Offset 4	0	3	16	0	0.0	15
		Relative Secondary Offset	0	4	30	15	0.0	32
Extra Time Phases		Permissive Period	Auto	5	0	0	0.0	0
		Max Cycle Addition	18	6	29	0	0.0	30
Additional Max Recalls		Max Cycle Subtraction	18	7	0	0	0.0	0
		Coord Actuated Period	0	8	46	0	0.0	52
Units	Seconds	Top Of Cycle Green Point	End	9	0	0	0.0	0
		Big Bang Preempt Recvry	No	10	0	0	0.0	0
		Big Bang Ped Recovery	No	11	0	0	0.0	0
		Min Lagging Left Split	0%	12	0	0	0.0	0

Intersection 643 at Old Ranch Rd and Chapel Ridge Dr - Timing table, page 1

Page 1	Phases											
	1	2	3	4	5	6	7	8	9	10	11	12
Min Green	4	6	4	4	4	6	4	4	0	0	0	0
Passage Time I	1.0	1.0	1.0	1.0	1.0	1.0	1.0	1.0	0.0	0.0	0.0	0.0
Passage Time II	2.0	2.0	2.0	2.0	2.0	2.0	2.0	2.0	0.0	0.0	0.0	0.0
Max Green I	15	45	15	20	15	45	15	20	0	0	0	0
Max Green II	7	25	7	10	7	25	7	10	0	0	0	0
Yellow Clearance	4.0	4.0	4.5	4.5	4.0	4.0	4.5	4.5	0.0	0.0	0.0	0.0
Red Clearance	2.0	2.0	2.0	2.0	2.0	2.0	2.0	2.0	0.0	0.0	0.0	0.0
Added Initial	0.0	0.0	0.0	0.0	0.0	0.0	0.0	0.0	0.0	0.0	0.0	0.0
Max Added Initial	0	0	0	0	0	0	0	0	0	0	0	0
Time Before Reduction	0	0	0	0	0	0	0	0	0	0	0	0
Cars Before Reduction	0	0	0	0	0	0	0	0	0	0	0	0
Time To Reduce	0	0	0	0	0	0	0	0	0	0	0	0
Min Passage	0.0	0.0	0.0	0.0	0.0	0.0	0.0	0.0	0.0	0.0	0.0	0.0
Recall Green Time	0	0	0	0	0	0	0	0	0	0	0	0
Red Revert Time	0.0	0.0	0.0	0.0	0.0	0.0	0.0	0.0	0.0	0.0	0.0	0.0
Walk Time	0	7	0	7	0	7	0	7	0	0	0	0
Pedestrian Clearance	0	28	0	31	0	28	0	31	0	0	0	0
Handicap Walk	0	12	0	12	0	12	0	12	0	0	0	0
Handicap Ped Clearance	0	33	0	36	0	33	0	36	0	0	0	0
Old Ranch Rd	X	X			X	X						
Chapel Ridge Dr			X	X			X	X				
Compass Direction	W	E	S	N	E	W	N	S				
Through, Turn or XPed	Left,prt	Thru	Left,prt	Thru	Left,prt	Thru	Left,prt	Thru				

Intersection 643 at Old Ranch Rd and Chapel Ridge Dr - Sequence table, page 1

Page 1	Ring 1 Phases				Ring 2 Phases				Ring 3 Phases			
	1	2	3	4	5	6	7	8	9	10	11	12
State 1		V & P				V & P						
Barrier 1												
State 2	Vehicle				Vehicle							
Barrier 2	XXXXXXXXXXXXXXXXXXXXXXXXXX				XXXXXXXXXXXXXXXXXXXXXXXXXX							
State 3				V & P				V & P				
Barrier 3												
State 4			Vehicle				Vehicle					
Barrier 4	XXXXXXXXXXXXXXXXXXXXXXXXXX				XXXXXXXXXXXXXXXXXXXXXXXXXX							
State 5												
Barrier 5												
State 6												
Barrier 6												
State 7												
Barrier 7												
State 8												
Barrier 8												
State 9												
Barrier 9												
State 10												
Barrier 10												
State 11												
Barrier 11												
State 12												
Barrier 12												

Intersection 643 at Old Ranch Rd and Chapel Ridge Dr - Phases control table, page 1

Page 1	Vehicle Phases		Ped Phases
	_____111 123456789012		_____111 123456789012
Min Recalls		Ped Recalls	
Max Recalls	2 6	Handicap Ped Recalls	
Recall If Maxed		Soft Ped Recalls	
Dual Entry	4 8	Do Not Recall Ped	2 4 6 8
Do Not Skip		Allow Walk Reduction	
Simultaneous Gap Out		Hold In Walk	
Restricted Phases		Allow Ped Re-service	
Sequential Initial Timing		Rest In Walk	No
Max Timer Starts For Call			
Reduction Starts For Call			
Red To Avoid Left Turn Trap			
Rest In Red	No		

Intersection 643 at Old Ranch Rd and Chapel Ridge Dr - Spec signaling cntrl tbl, pg 1

Page 1							
Signaling Control 1				Signaling Control 2			
Function	Flashing permissive left turn	Timer 1	2.0	Function	Flashing permissive left turn	Timer 1	2.0
Operand	0	Timer 2	0.0	Operand	0	Timer 2	0.0
Trigger	Always enabled	Timer 3	0.0	Trigger	Always enabled	Timer 3	0.0
	111	Output 1	25		111	Output 1	1
	123456789012	Output 2	34		123456789012	Output 2	35
Phases 1	5	Output 3	41	Phases 1	1	Output 3	40
Phases 2	2 6	Output 4	1	Phases 2	2 6	Output 4	1
Overlaps 1				Overlaps 1			
Overlaps 2				Overlaps 2			
Signaling Control 3				Signaling Control 4			
Function	Flashing permissive left turn	Timer 1	2.0	Function	Flashing permissive left turn	Timer 1	2.0
Operand	0	Timer 2	0.0	Operand	0	Timer 2	0.0
Trigger	Always enabled	Timer 3	0.0	Trigger	Always enabled	Timer 3	0.0
	111	Output 1	17		111	Output 1	9
	123456789012	Output 2	36		123456789012	Output 2	33
Phases 1	3	Output 3	44	Phases 1	7	Output 3	43
Phases 2	4 8	Output 4	1	Phases 2	4 8	Output 4	1
Overlaps 1				Overlaps 1			
Overlaps 2				Overlaps 2			

Intersection 643 at Old Ranch Rd and Chapel Ridge Dr - Schedule table, events 1-25

Event Num	Enabled	Event Type	Event Parameters		Start					Duration Minutes	Stop		Repetition		Priority
			Param 1	Param 2	Mon	Day	Hour	Min	Sec		Mon	Day	Repeat	Intervals	
1	Yes	Run Plan	Plan 3	Ofst #1	1	1	08	30	00	360	12	31	Weekly	MTWTF	Low
2	Yes	Run Plan	Plan 1	Ofst #1	1	1	06	30	00	120	12	31	Weekly	MTWTF	Low
3	Yes	Run Plan	Plan 1	Ofst #1	1	1	14	30	00	210	12	31	Weekly	MTWTF	Low
4	Yes	Use Max Green II			1	1	22	00	00	120	12	31	Weekly	SMTWTFS	Low
5	Yes	Use Max Green II			1	1	00	00	00	390	12	31	Weekly	SMTWTFS	Low
6	Yes	Run Plan	Plan 4	Ofst #1	1	1	18	00	00	240	12	31	Weekly	MTWTF	Very Low
7	Yes	Run Plan	Plan 4	Ofst #1	1	1	07	30	00	870	12	31	Weekly	S S	Very Low
8															
9															
10															
11															
12															
13															
14															
15															
16															
17															
18															
19															
20															
21															
22															
23															
24															
25															

Intersection 643 at Old Ranch Rd and Chapel Ridge Dr - Coordination table, plans 1-2

Plan 1	111	Cycle Length	114	Phases	Splits	Alternate Mins	Alternate Passages	Alternate Maxes
	123456789012	Offset 1	33					
Coordinated Phases		Offset 2	0	1	14	0	0.0	12
	2 6	Offset 3	0	2	56	0	0.0	65
Secondary Coordinated Phases		Offset 4	0	3	17	0	0.0	15
		Relative Secondary Offset	0	4	27	0	0.0	27
Extra Time Phases		Permissive Period	Auto	5	14	0	0.0	12
		Max Cycle Addition	28	6	56	0	0.0	65
Additional Max Recalls		Max Cycle Subtraction	28	7	17	0	0.0	15
		Coord Actuated Period	0	8	27	0	0.0	27
Units	Seconds	Top Of Cycle Green Point	End	9	0	0	0.0	0
		Big Bang Preempt Recvry	No	10	0	0	0.0	0
		Big Bang Ped Recovery	No	11	0	0	0.0	0
		Min Lagging Left Split	0%	12	0	0	0.0	0
Plan 2	111	Cycle Length	0	Phases	Splits	Alternate Mins	Alternate Passages	Alternate Maxes
	123456789012	Offset 1	0					
Coordinated Phases		Offset 2	0	1	0	0	0.0	0
		Offset 3	0	2	0	0	0.0	0
Secondary Coordinated Phases		Offset 4	0	3	0	0	0.0	0
		Relative Secondary Offset	0	4	0	0	0.0	0
Extra Time Phases		Permissive Period	Auto	5	0	0	0.0	0
		Max Cycle Addition	0	6	0	0	0.0	0
Additional Max Recalls		Max Cycle Subtraction	0	7	0	0	0.0	0
		Coord Actuated Period	0	8	0	0	0.0	0
Units	Seconds	Top Of Cycle Green Point	End	9	0	0	0.0	0
		Big Bang Preempt Recvry	No	10	0	0	0.0	0
		Big Bang Ped Recovery	No	11	0	0	0.0	0
		Min Lagging Left Split	0%	12	0	0	0.0	0

Intersection 643 at Old Ranch Rd and Chapel Ridge Dr - Coordination table, plans 3-4

Plan 3	111	Cycle Length	94	Phases	Splits	Alternate Mins	Alternate Passages	Alternate Maxes
	123456789012	Offset 1	31					
Coordinated Phases		Offset 2	0	1	13	0	0.0	11
	2 6	Offset 3	0	2	42	0	0.0	47
Secondary Coordinated Phases		Offset 4	0	3	17	0	0.0	15
		Relative Secondary Offset	0	4	22	0	0.0	21
Extra Time Phases		Permissive Period	Auto	5	13	0	0.0	11
		Max Cycle Addition	23	6	42	0	0.0	47
Additional Max Recalls		Max Cycle Subtraction	23	7	17	0	0.0	15
		Coord Actuated Period	0	8	22	0	0.0	21
Units	Seconds	Top Of Cycle Green Point	End	9	0	0	0.0	0
		Big Bang Preempt Recvry	No	10	0	0	0.0	0
		Big Bang Ped Recovery	No	11	0	0	0.0	0
		Min Lagging Left Split	0%	12	0	0	0.0	0
Plan 4	111	Cycle Length	75	Phases	Splits	Alternate Mins	Alternate Passages	Alternate Maxes
	123456789012	Offset 1	5					
Coordinated Phases		Offset 2	0	1	12	0	0.0	10
	2 6	Offset 3	0	2	25	0	0.0	26
Secondary Coordinated Phases		Offset 4	0	3	13	0	0.0	10
		Relative Secondary Offset	0	4	25	0	0.0	25
Extra Time Phases		Permissive Period	Auto	5	12	0	0.0	10
		Max Cycle Addition	25	6	25	0	0.0	26
Additional Max Recalls		Max Cycle Subtraction	0	7	13	0	0.0	10
		Coord Actuated Period	0	8	25	0	0.0	25
Units	Seconds	Top Of Cycle Green Point	End	9	0	0	0.0	0
		Big Bang Preempt Recvry	No	10	0	0	0.0	0
		Big Bang Ped Recovery	No	11	0	0	0.0	0
		Min Lagging Left Split	0%	12	0	0	0.0	0

APPENDIX F

Signal Warrant Analysis Worksheets

WARRANT 2 - FOUR HOUR VEHICULAR VOLUME

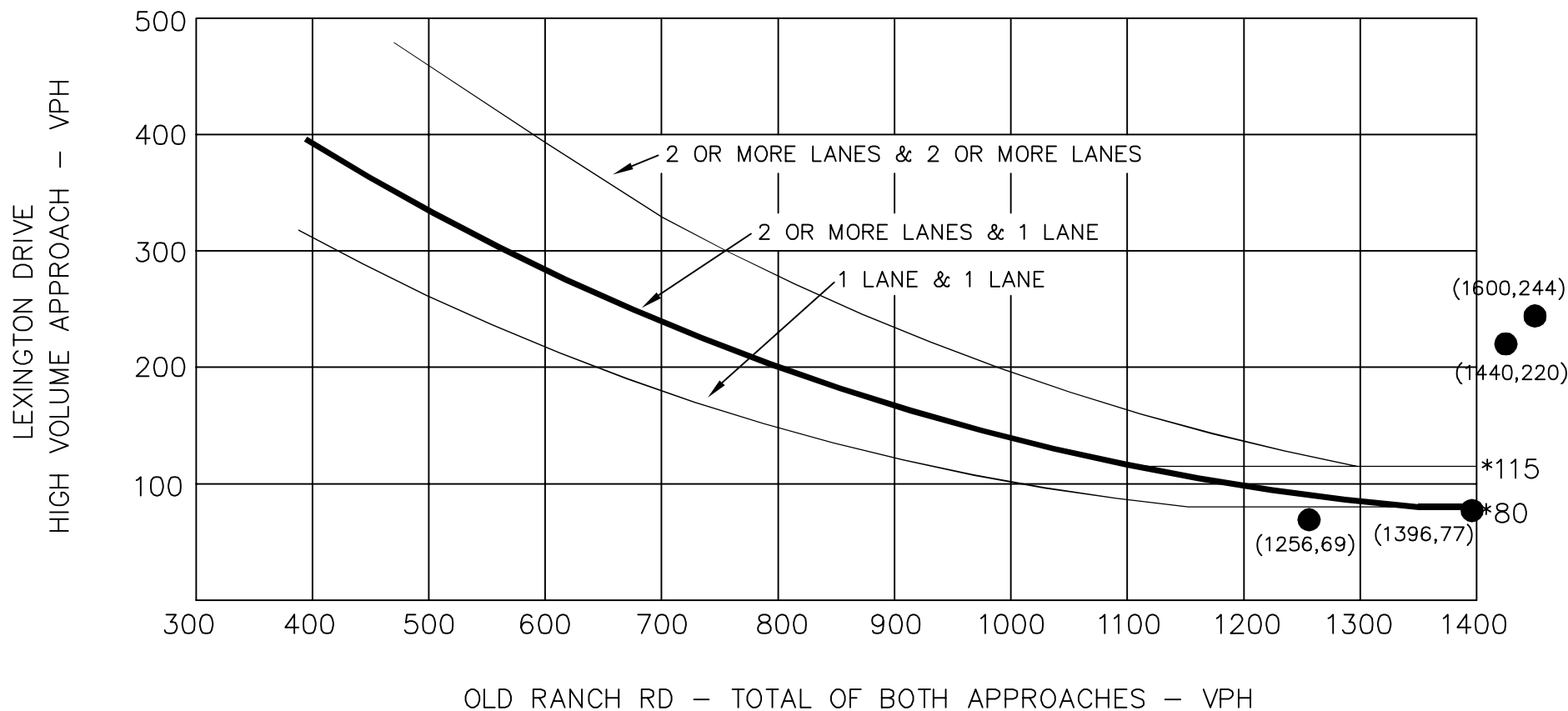

* NOTE: 115 VPH APPLIES AS THE LOWER THRESHOLD VOLUME FOR A MINOR STREET APPROACH WITH TWO OR MORE LANES AND 80 VPH APPLIES AS THE LOWER THRESHOLD VOLUME FOR A MINOR STREET APPROACHING WITH ONE LANE.

OLD RANCH RD & LEXINGTON DR
SIGNAL WARRANT ANALYSIS
FOUR HOUR VOLUME WARRANT

● 2045 TOTAL TRAFFIC DATA POINT

Source: Manual of Uniform Traffic Control Devices 2009



APPENDIX G

Queue Analysis Worksheets

Queues

1: Voyager Pkwy & Old Ranch Rd



Lane Group	EBL	EBT	WBL	WBT	WBR	NBL	NBT	NBR	SBL	SBT
Lane Group Flow (vph)	4	7	378	1	367	1	780	143	212	606
v/c Ratio	0.01	0.01	0.81	0.00	0.48	0.00	0.81	0.27	0.64	0.40
Control Delay	13.3	12.0	35.2	13.0	4.1	11.0	34.2	6.1	22.9	16.3
Queue Delay	0.0	0.0	0.0	0.0	0.0	0.0	0.0	0.0	0.0	0.0
Total Delay	13.3	12.0	35.2	13.0	4.1	11.0	34.2	6.1	22.9	16.3
Queue Length 50th (ft)	1	1	136	0	0	0	173	0	51	88
Queue Length 95th (ft)	6	8	200	3	35	2	#250	33	#107	156
Internal Link Dist (ft)		1391		6569			655			1462
Turn Bay Length (ft)	100		225		225	325		275	300	
Base Capacity (vph)	541	686	538	715	834	449	967	537	335	1534
Starvation Cap Reductn	0	0	0	0	0	0	0	0	0	0
Spillback Cap Reductn	0	0	0	0	0	0	0	0	0	0
Storage Cap Reductn	0	0	0	0	0	0	0	0	0	0
Reduced v/c Ratio	0.01	0.01	0.70	0.00	0.44	0.00	0.81	0.27	0.63	0.40

Intersection Summary

95th percentile volume exceeds capacity, queue may be longer.
 Queue shown is maximum after two cycles.

Queues

2025 Total PM

1: Voyager Pkwy & Old Ranch Rd

09/06/2023



Lane Group	EBL	EBT	WBL	WBT	WBR	NBL	NBT	NBR	SBL	SBT	SBR
Lane Group Flow (vph)	2	2	171	1	141	6	646	340	369	691	3
v/c Ratio	0.01	0.00	0.63	0.00	0.33	0.01	0.48	0.42	0.68	0.34	0.00
Control Delay	19.5	0.0	35.0	19.0	6.0	6.7	18.5	4.0	16.7	10.2	0.0
Queue Delay	0.0	0.0	0.0	0.0	0.0	0.0	0.0	0.0	0.0	0.0	0.0
Total Delay	19.5	0.0	35.0	19.0	6.0	6.7	18.5	4.0	16.7	10.2	0.0
Queue Length 50th (ft)	1	0	67	0	0	1	114	0	62	67	0
Queue Length 95th (ft)	5	0	114	4	34	5	162	50	#183	165	0
Internal Link Dist (ft)		1391		6569			655			1462	
Turn Bay Length (ft)	100		225		225	325		275	300		175
Base Capacity (vph)	378	666	378	499	534	507	1345	812	542	2021	961
Starvation Cap Reductn	0	0	0	0	0	0	0	0	0	0	0
Spillback Cap Reductn	0	0	0	0	0	0	0	0	0	0	0
Storage Cap Reductn	0	0	0	0	0	0	0	0	0	0	0
Reduced v/c Ratio	0.01	0.00	0.45	0.00	0.26	0.01	0.48	0.42	0.68	0.34	0.00

Intersection Summary

95th percentile volume exceeds capacity, queue may be longer.
 Queue shown is maximum after two cycles.

Queues
1: Voyager Pkwy & Old Ranch Rd

2045 Total AM
09/06/2023



Lane Group	EBL	EBT	WBL	WBT	WBR	NBL	NBT	NBR	SBL	SBT
Lane Group Flow (vph)	5	11	492	1	476	1	1049	187	278	816
v/c Ratio	0.01	0.02	0.89	0.00	0.61	0.00	1.24	0.36	1.01	0.62
Control Delay	12.0	10.2	40.5	12.0	10.8	12.0	144.8	6.1	81.4	22.8
Queue Delay	0.0	0.0	0.0	0.0	0.0	0.0	0.0	0.0	0.0	0.0
Total Delay	12.0	10.2	40.5	12.0	10.8	12.0	144.8	6.1	81.4	22.8
Queue Length 50th (ft)	1	2	182	0	62	0	-297	0	-92	141
Queue Length 95th (ft)	7	9	#306	3	121	3	#364	36	#215	#254
Internal Link Dist (ft)		1391		6569			655			1462
Turn Bay Length (ft)	100		225		225	325		275	300	
Base Capacity (vph)	582	729	577	769	803	286	846	520	275	1321
Starvation Cap Reductn	0	0	0	0	0	0	0	0	0	0
Spillback Cap Reductn	0	0	0	0	0	0	0	0	0	0
Storage Cap Reductn	0	0	0	0	0	0	0	0	0	0
Reduced v/c Ratio	0.01	0.02	0.85	0.00	0.59	0.00	1.24	0.36	1.01	0.62

Intersection Summary

- ~ Volume exceeds capacity, queue is theoretically infinite.
Queue shown is maximum after two cycles.
- # 95th percentile volume exceeds capacity, queue may be longer.
Queue shown is maximum after two cycles.

Queues
1: Voyager Pkwy & Old Ranch Rd

2045 Total PM
09/06/2023



Lane Group	EBL	EBT	WBL	WBT	WBR	NBL	NBT	NBR	SBL	SBT	SBR
Lane Group Flow (vph)	3	3	218	1	178	9	870	438	476	931	4
v/c Ratio	0.01	0.01	0.72	0.00	0.34	0.03	0.88	0.58	0.90	0.48	0.00
Control Delay	19.3	0.0	38.7	19.0	3.4	8.9	40.7	6.4	37.3	11.9	0.0
Queue Delay	0.0	0.0	0.0	0.0	0.0	0.0	0.0	0.0	0.0	0.0	0.0
Total Delay	19.3	0.0	38.7	19.0	3.4	8.9	40.7	6.4	37.3	11.9	0.0
Queue Length 50th (ft)	1	0	85	0	0	1	-220	0	133	110	0
Queue Length 95th (ft)	7	0	148	4	24	7	#351	71	#303	228	0
Internal Link Dist (ft)		1391		6569			655			1462	
Turn Bay Length (ft)	100		225		225	325		275	300		175
Base Capacity (vph)	367	588	367	486	582	317	989	757	573	1958	935
Starvation Cap Reductn	0	0	0	0	0	0	0	0	0	0	0
Spillback Cap Reductn	0	0	0	0	0	0	0	0	0	0	0
Storage Cap Reductn	0	0	0	0	0	0	0	0	0	0	0
Reduced v/c Ratio	0.01	0.01	0.59	0.00	0.31	0.03	0.88	0.58	0.83	0.48	0.00

Intersection Summary

- ~ Volume exceeds capacity, queue is theoretically infinite.
Queue shown is maximum after two cycles.
- # 95th percentile volume exceeds capacity, queue may be longer.
Queue shown is maximum after two cycles.

Queues
3: Chapel Ridge Dr & Old Ranch Rd

2025 Total AM
09/06/2023



Lane Group	EBL	EBT	EBR	WBL	WBT	WBR	NBL	NBT	NBR	SBL	SBT	SBR
Lane Group Flow (vph)	71	496	68	141	859	46	85	13	200	148	24	211
v/c Ratio	0.23	0.32	0.09	0.30	0.52	0.06	0.22	0.02	0.44	0.36	0.03	0.42
Control Delay	13.6	21.5	0.2	24.9	37.3	2.0	28.9	38.7	9.0	31.3	38.5	8.2
Queue Delay	0.0	0.0	0.0	0.0	0.0	0.0	0.0	0.0	0.0	0.0	0.0	0.0
Total Delay	13.6	21.5	0.2	24.9	37.3	2.0	28.9	38.7	9.0	31.3	38.5	8.2
Queue Length 50th (ft)	23	122	0	65	287	0	44	4	0	79	7	0
Queue Length 95th (ft)	39	141	0	107	315	7	72	12	41	115	17	41
Internal Link Dist (ft)		990			1540			479			1275	
Turn Bay Length (ft)	325		175	300			200		150	150		125
Base Capacity (vph)	319	1558	782	467	1649	819	417	651	454	413	765	507
Starvation Cap Reductn	0	0	0	0	0	0	0	0	0	0	0	0
Spillback Cap Reductn	0	0	0	0	0	0	0	0	0	0	0	0
Storage Cap Reductn	0	0	0	0	0	0	0	0	0	0	0	0
Reduced v/c Ratio	0.22	0.32	0.09	0.30	0.52	0.06	0.20	0.02	0.44	0.36	0.03	0.42

Intersection Summary

Queues

2025 Total PM

3: Chapel Ridge Dr & Old Ranch Rd

09/06/2023



Lane Group	EBL	EBT	EBR	WBL	WBT	WBR	NBL	NBT	NBR	SBL	SBT	SBR
Lane Group Flow (vph)	187	425	51	83	228	105	38	26	83	75	12	102
v/c Ratio	0.30	0.26	0.06	0.16	0.15	0.13	0.09	0.03	0.18	0.18	0.01	0.20
Control Delay	14.1	19.9	0.1	10.1	17.2	2.1	27.3	38.3	1.0	28.2	36.7	2.9
Queue Delay	0.0	0.0	0.0	0.0	0.0	0.0	0.0	0.0	0.0	0.0	0.0	0.0
Total Delay	14.1	19.9	0.1	10.1	17.2	2.1	27.3	38.3	1.0	28.2	36.7	2.9
Queue Length 50th (ft)	64	102	0	18	53	6	19	8	0	38	3	0
Queue Length 95th (ft)	103	139	0	37	84	19	44	21	1	74	12	17
Internal Link Dist (ft)		990			1540			479			1275	
Turn Bay Length (ft)	325		175	300			200		150	150		125
Base Capacity (vph)	617	1645	817	523	1552	780	441	773	461	433	892	510
Starvation Cap Reductn	0	0	0	0	0	0	0	0	0	0	0	0
Spillback Cap Reductn	0	0	0	0	0	0	0	0	0	0	0	0
Storage Cap Reductn	0	0	0	0	0	0	0	0	0	0	0	0
Reduced v/c Ratio	0.30	0.26	0.06	0.16	0.15	0.13	0.09	0.03	0.18	0.17	0.01	0.20

Intersection Summary

Queues
3: Chapel Ridge Dr & Old Ranch Rd

2045 Total AM
09/06/2023



Lane Group	EBL	EBT	EBR	WBL	WBT	WBR	NBL	NBT	NBR	SBL	SBT	SBR
Lane Group Flow (vph)	71	668	90	191	1158	46	115	13	269	148	24	211
v/c Ratio	0.33	0.43	0.12	0.50	0.70	0.06	0.29	0.02	0.53	0.36	0.04	0.45
Control Delay	15.9	23.2	0.5	28.7	39.2	1.0	29.9	38.7	9.0	31.3	38.8	8.9
Queue Delay	0.0	0.0	0.0	0.0	0.0	0.0	0.0	0.0	0.0	0.0	0.0	0.0
Total Delay	15.9	23.2	0.5	28.7	39.2	1.0	29.9	38.7	9.0	31.3	38.8	8.9
Queue Length 50th (ft)	23	174	0	99	348	0	60	4	0	79	7	0
Queue Length 95th (ft)	39	193	0	135	376	5	93	12	43	115	17	41
Internal Link Dist (ft)		990			1540			479			1275	
Turn Bay Length (ft)	325		175	300			200		150	150		125
Base Capacity (vph)	228	1552	780	385	1649	819	417	651	510	420	665	468
Starvation Cap Reductn	0	0	0	0	0	0	0	0	0	0	0	0
Spillback Cap Reductn	0	0	0	0	0	0	0	0	0	0	0	0
Storage Cap Reductn	0	0	0	0	0	0	0	0	0	0	0	0
Reduced v/c Ratio	0.31	0.43	0.12	0.50	0.70	0.06	0.28	0.02	0.53	0.35	0.04	0.45

Intersection Summary

Queues

2045 Total PM

3: Chapel Ridge Dr & Old Ranch Rd

09/06/2023

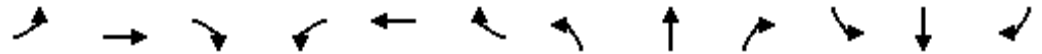

Lane Group	EBL	EBT	EBR	WBL	WBT	WBR	NBL	NBT	NBR	SBL	SBT	SBR
Lane Group Flow (vph)	187	574	69	112	307	105	52	26	112	75	12	102
v/c Ratio	0.32	0.37	0.09	0.26	0.20	0.13	0.13	0.03	0.24	0.18	0.02	0.22
Control Delay	14.3	22.1	0.2	15.6	20.3	3.3	27.7	38.3	4.1	28.3	37.7	3.1
Queue Delay	0.0	0.0	0.0	0.0	0.0	0.0	0.0	0.0	0.0	0.0	0.0	0.0
Total Delay	14.3	22.1	0.2	15.6	20.3	3.3	27.7	38.3	4.1	28.3	37.7	3.1
Queue Length 50th (ft)	64	145	0	28	75	6	26	8	0	38	3	0
Queue Length 95th (ft)	103	190	0	73	119	21	56	21	26	74	12	17
Internal Link Dist (ft)		990			1540			479			1275	
Turn Bay Length (ft)	325		175	300			200		150	150		125
Base Capacity (vph)	581	1562	784	430	1552	780	441	773	461	439	794	470
Starvation Cap Reductn	0	0	0	0	0	0	0	0	0	0	0	0
Spillback Cap Reductn	0	0	0	0	0	0	0	0	0	0	0	0
Storage Cap Reductn	0	0	0	0	0	0	0	0	0	0	0	0
Reduced v/c Ratio	0.32	0.37	0.09	0.26	0.20	0.13	0.12	0.03	0.24	0.17	0.02	0.22

Intersection Summary

4: Powers Blvd SB Ramp & Old Ranch Rd

09/06/2023

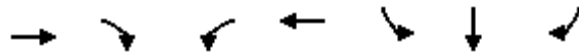

Lane Group	EBT	EBR	WBL	WBT	SBL	SBT	SBR
Lane Group Flow (vph)	525	378	419	1014	78	77	64
v/c Ratio	0.26	0.24	0.69	0.41	0.25	0.21	0.04
Control Delay	10.5	0.4	17.1	11.0	41.8	8.4	0.1
Queue Delay	0.0	0.0	0.0	0.0	0.0	0.0	0.0
Total Delay	10.5	0.4	17.1	11.0	41.8	8.4	0.1
Queue Length 50th (ft)	62	1	160	213	51	0	0
Queue Length 95th (ft)	78	0	m168	m198	84	24	0
Internal Link Dist (ft)	1540			634		759	
Turn Bay Length (ft)		275	200		725		725
Base Capacity (vph)	1986	1583	610	2483	317	371	1504
Starvation Cap Reductn	0	0	0	0	0	0	0
Spillback Cap Reductn	0	0	0	0	0	0	0
Storage Cap Reductn	0	0	0	0	0	0	0
Reduced v/c Ratio	0.26	0.24	0.69	0.41	0.25	0.21	0.04

Intersection Summary

m Volume for 95th percentile queue is metered by upstream signal.

4: Powers Blvd SB Ramp & Old Ranch Rd

09/06/2023

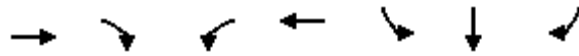

Lane Group	EBT	EBR	WBL	WBT	SBL	SBT	SBR
Lane Group Flow (vph)	336	260	224	383	53	54	49
v/c Ratio	0.17	0.16	0.31	0.15	0.17	0.18	0.03
Control Delay	6.8	0.3	9.4	8.1	40.5	37.6	0.0
Queue Delay	0.0	0.0	0.0	0.0	0.0	0.0	0.0
Total Delay	6.8	0.3	9.4	8.1	40.5	37.6	0.0
Queue Length 50th (ft)	26	0	66	58	34	32	0
Queue Length 95th (ft)	36	5	m97	78	72	74	0
Internal Link Dist (ft)	1540			634		759	
Turn Bay Length (ft)		275	200		725		725
Base Capacity (vph)	2004	1583	730	2483	317	305	1504
Starvation Cap Reductn	0	0	0	0	0	0	0
Spillback Cap Reductn	0	0	0	0	0	0	0
Storage Cap Reductn	0	0	0	0	0	0	0
Reduced v/c Ratio	0.17	0.16	0.31	0.15	0.17	0.18	0.03

Intersection Summary

m Volume for 95th percentile queue is metered by upstream signal.

Queues

2045 Total AM

4: Powers Blvd SB Ramp & Old Ranch Rd

09/06/2023

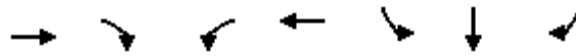

Lane Group	EBT	EBR	WBL	WBT	SBL	SBT	SBR
Lane Group Flow (vph)	695	490	566	1358	106	104	85
v/c Ratio	0.35	0.31	0.93	0.51	0.46	0.36	0.06
Control Delay	6.1	0.6	26.8	8.4	52.8	16.9	0.1
Queue Delay	0.0	0.0	0.0	0.6	0.0	0.0	0.0
Total Delay	6.1	0.6	26.8	9.0	52.8	16.9	0.1
Queue Length 50th (ft)	48	3	210	283	76	13	0
Queue Length 95th (ft)	64	0	m163	m208	115	48	0
Internal Link Dist (ft)	1540			634		759	
Turn Bay Length (ft)		275	200		725		725
Base Capacity (vph)	1986	1583	610	2669	228	291	1504
Starvation Cap Reductn	0	0	0	826	0	0	0
Spillback Cap Reductn	0	0	0	0	0	0	0
Storage Cap Reductn	0	0	0	0	0	0	0
Reduced v/c Ratio	0.35	0.31	0.93	0.74	0.46	0.36	0.06

Intersection Summary

m Volume for 95th percentile queue is metered by upstream signal.

Queues

2045 Total PM

4: Powers Blvd SB Ramp & Old Ranch Rd

09/06/2023

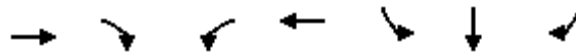

Lane Group	EBT	EBR	WBL	WBT	SBL	SBT	SBR
Lane Group Flow (vph)	447	341	302	494	72	71	60
v/c Ratio	0.22	0.22	0.46	0.20	0.23	0.23	0.04
Control Delay	4.0	0.5	11.1	8.3	41.5	39.4	0.1
Queue Delay	0.0	0.0	0.0	0.0	0.0	0.0	0.0
Total Delay	4.0	0.5	11.1	8.3	41.5	39.4	0.1
Queue Length 50th (ft)	17	1	94	78	47	46	0
Queue Length 95th (ft)	23	9	m126	m97	92	93	0
Internal Link Dist (ft)	1540			634		759	
Turn Bay Length (ft)		275	200		725		725
Base Capacity (vph)	1991	1583	659	2483	317	305	1504
Starvation Cap Reductn	0	0	0	0	0	0	0
Spillback Cap Reductn	0	0	0	0	0	0	0
Storage Cap Reductn	0	0	0	0	0	0	0
Reduced v/c Ratio	0.22	0.22	0.46	0.20	0.23	0.23	0.04

Intersection Summary

m Volume for 95th percentile queue is metered by upstream signal.

5: Powers Blvd NB Ramp & Old Ranch Rd

09/06/2023



Lane Group	EBL	EBT	WBT	WBR	NBL	NBT	NBR
Lane Group Flow (vph)	71	610	1040	179	266	253	246
v/c Ratio	0.18	0.22	0.43	0.11	1.34	1.00	0.16
Control Delay	10.1	12.3	9.3	0.1	221.0	89.5	0.2
Queue Delay	0.0	0.0	0.0	0.0	0.0	0.0	0.0
Total Delay	10.1	12.3	9.3	0.1	221.0	89.5	0.2
Queue Length 50th (ft)	29	158	175	0	-267	140	0
Queue Length 95th (ft)	45	170	178	0	#356	#239	0
Internal Link Dist (ft)		634	1062			612	
Turn Bay Length (ft)	200			625			525
Base Capacity (vph)	460	2731	2415	1583	199	254	1504
Starvation Cap Reductn	0	0	0	0	0	0	0
Spillback Cap Reductn	0	0	0	0	0	0	0
Storage Cap Reductn	0	0	0	0	0	0	0
Reduced v/c Ratio	0.15	0.22	0.43	0.11	1.34	1.00	0.16

Intersection Summary

- ~ Volume exceeds capacity, queue is theoretically infinite.
Queue shown is maximum after two cycles.
- # 95th percentile volume exceeds capacity, queue may be longer.
Queue shown is maximum after two cycles.

Queues

2025 Total PM

5: Powers Blvd NB Ramp & Old Ranch Rd

09/06/2023



Lane Group	EBL	EBT	WBT	WBR	NBL	NBT	NBR
Lane Group Flow (vph)	45	408	360	110	149	142	136
v/c Ratio	0.06	0.15	0.15	0.07	0.75	0.61	0.09
Control Delay	7.1	8.8	6.9	0.1	72.0	39.0	0.1
Queue Delay	0.0	0.0	0.0	0.0	0.0	0.0	0.0
Total Delay	7.1	8.8	6.9	0.1	72.0	39.0	0.1
Queue Length 50th (ft)	0	92	46	0	112	60	0
Queue Length 95th (ft)	0	124	67	0	#220	136	0
Internal Link Dist (ft)		634	1062			612	
Turn Bay Length (ft)	200			625			525
Base Capacity (vph)	804	2731	2426	1583	199	233	1504
Starvation Cap Reductn	0	0	0	0	0	0	0
Spillback Cap Reductn	0	0	0	0	0	0	0
Storage Cap Reductn	0	0	0	0	0	0	0
Reduced v/c Ratio	0.06	0.15	0.15	0.07	0.75	0.61	0.09

Intersection Summary

95th percentile volume exceeds capacity, queue may be longer.
 Queue shown is maximum after two cycles.

Queues

2045 Total AM

5: Powers Blvd NB Ramp & Old Ranch Rd

09/06/2023



Lane Group	EBL	EBT	WBT	WBR	NBL	NBT	NBR
Lane Group Flow (vph)	88	817	1400	242	357	340	326
v/c Ratio	0.55	0.39	0.79	0.15	0.70	0.66	0.22
Control Delay	25.1	17.7	28.0	0.2	43.9	31.9	0.3
Queue Delay	0.0	0.0	0.0	0.0	0.0	0.0	0.0
Total Delay	25.1	17.7	28.0	0.2	43.9	31.9	0.3
Queue Length 50th (ft)	42	237	448	0	243	175	0
Queue Length 95th (ft)	56	238	420	0	291	224	0
Internal Link Dist (ft)		634	1062			612	
Turn Bay Length (ft)	200			625			525
Base Capacity (vph)	161	2079	1781	1583	508	517	1504
Starvation Cap Reductn	0	0	0	0	0	0	0
Spillback Cap Reductn	0	0	0	0	0	0	0
Storage Cap Reductn	0	0	0	0	0	0	0
Reduced v/c Ratio	0.55	0.39	0.79	0.15	0.70	0.66	0.22

Intersection Summary

Queues

2045 Total PM

5: Powers Blvd NB Ramp & Old Ranch Rd

09/06/2023



Lane Group	EBL	EBT	WBT	WBR	NBL	NBT	NBR
Lane Group Flow (vph)	56	547	482	149	192	186	179
v/c Ratio	0.08	0.20	0.20	0.09	0.96	0.77	0.12
Control Delay	11.5	14.0	7.3	0.1	106.1	50.8	0.2
Queue Delay	0.0	0.0	0.0	0.0	0.0	0.0	0.0
Total Delay	11.5	14.0	7.3	0.1	106.1	50.8	0.2
Queue Length 50th (ft)	0	136	65	0	149	89	0
Queue Length 95th (ft)	0	177	90	0	#303	#214	0
Internal Link Dist (ft)		634	1062			612	
Turn Bay Length (ft)	200			625			525
Base Capacity (vph)	734	2731	2420	1583	199	242	1504
Starvation Cap Reductn	0	0	0	0	0	0	0
Spillback Cap Reductn	0	0	0	0	0	0	0
Storage Cap Reductn	0	0	0	0	0	0	0
Reduced v/c Ratio	0.08	0.20	0.20	0.09	0.96	0.77	0.12

Intersection Summary

95th percentile volume exceeds capacity, queue may be longer.
Queue shown is maximum after two cycles.