

South Nevada Urban Renewal Area Streetscape Standards

City Council Adoption
Ryan Tefertiller
Jariah Walker

October 10, 2017



District formed in November 2015



Streetscape Design Standards



- Developer initiated
 - Significant feedback and support from City Staff
 - Significant coordination among developer groups
- Adopted by URA Board in April 2017

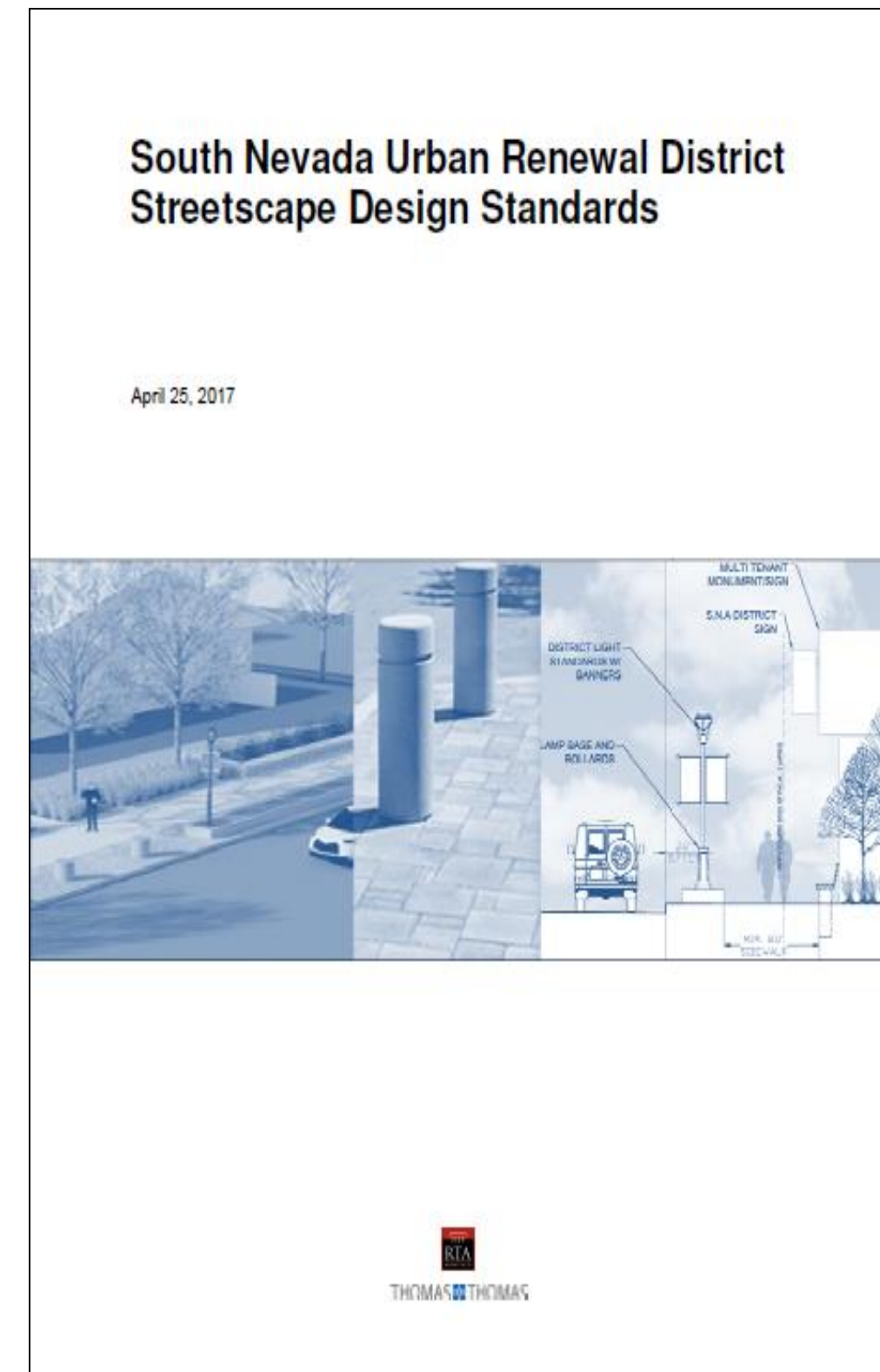

South Nevada Avenue URA Redevelopment Area

LEGEND

-  Overall Project Boundary (Proposed) 151.88 Acre
-  Property to be acquired for re-development by The Equity Group LLC (Proposed) 25.22 Acres
-  Property to be acquired for re-development by On The Ivy (Proposed) 12.07 Acres
-  Property to be acquired for re-development by Harder-Diesslin (Proposed) 4.05 Acres
-  Existing Property to Remain or Developed by Others 54.10 Acres
-  Existing Property to be Adjusted 0.52 Acres
-  Existing Right-of-Way to be Vacated 2.67 Acres
-  Existing Right-of-Way to Remain 53.04 Acres
-  Existing Traffic Light/ Proposed Traffic Light

STREETSCAPE ZONES

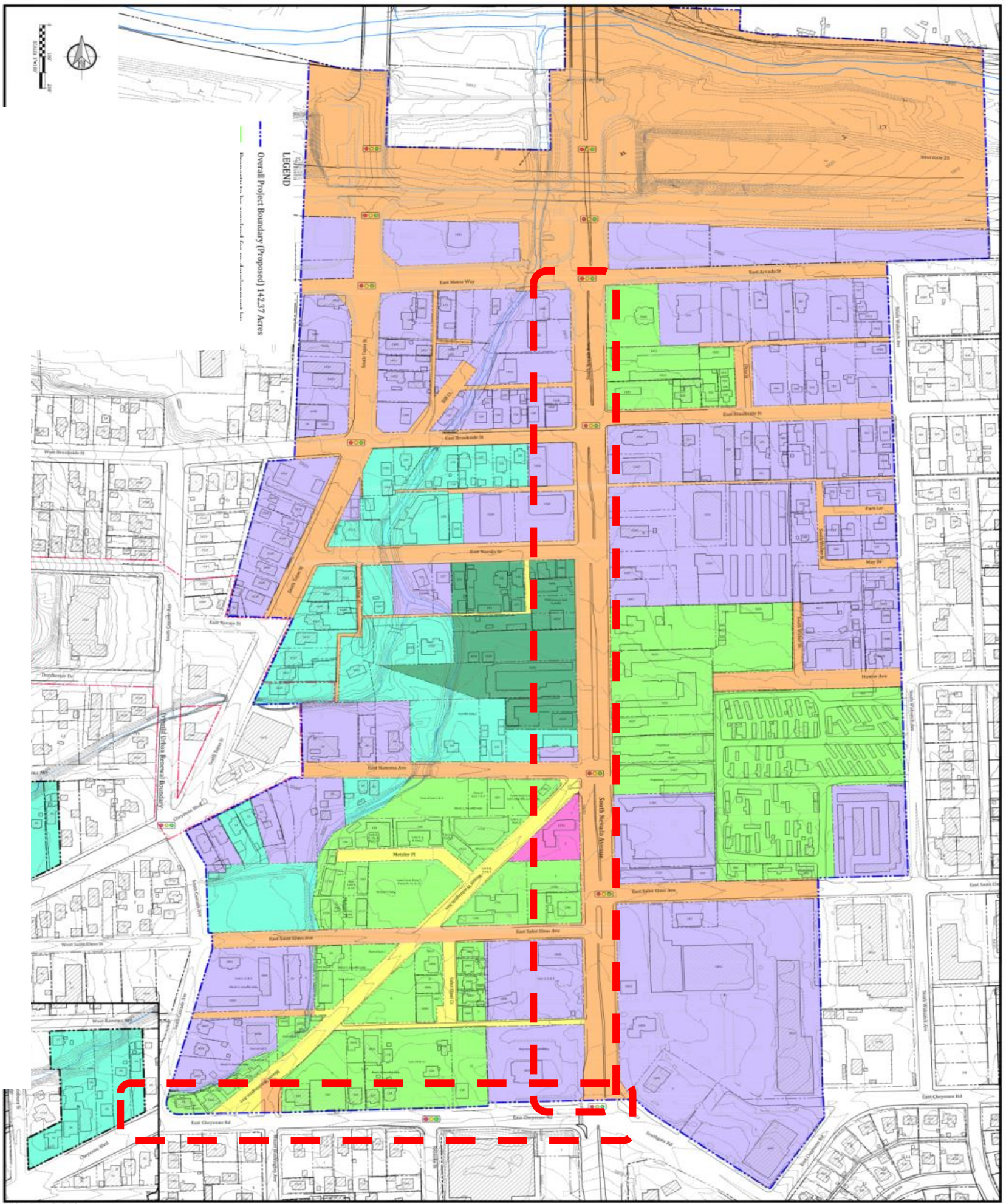

South Nevada Streetscape Design

Objectives:

- Provide a strong urban corridor with architectural rhythm and patterns
- Bring the Architecture up to the street to change the long-term character the street corridor
- Provide a safe and well defined pedestrian pathway
- Define a consistent palette of materials, colors and textures that hold the corridor together
- Respond to the needs of private investment within the corridor
- Finding balance for marketability, constructability and maintenance
- Provide a predictable and sustainable environment



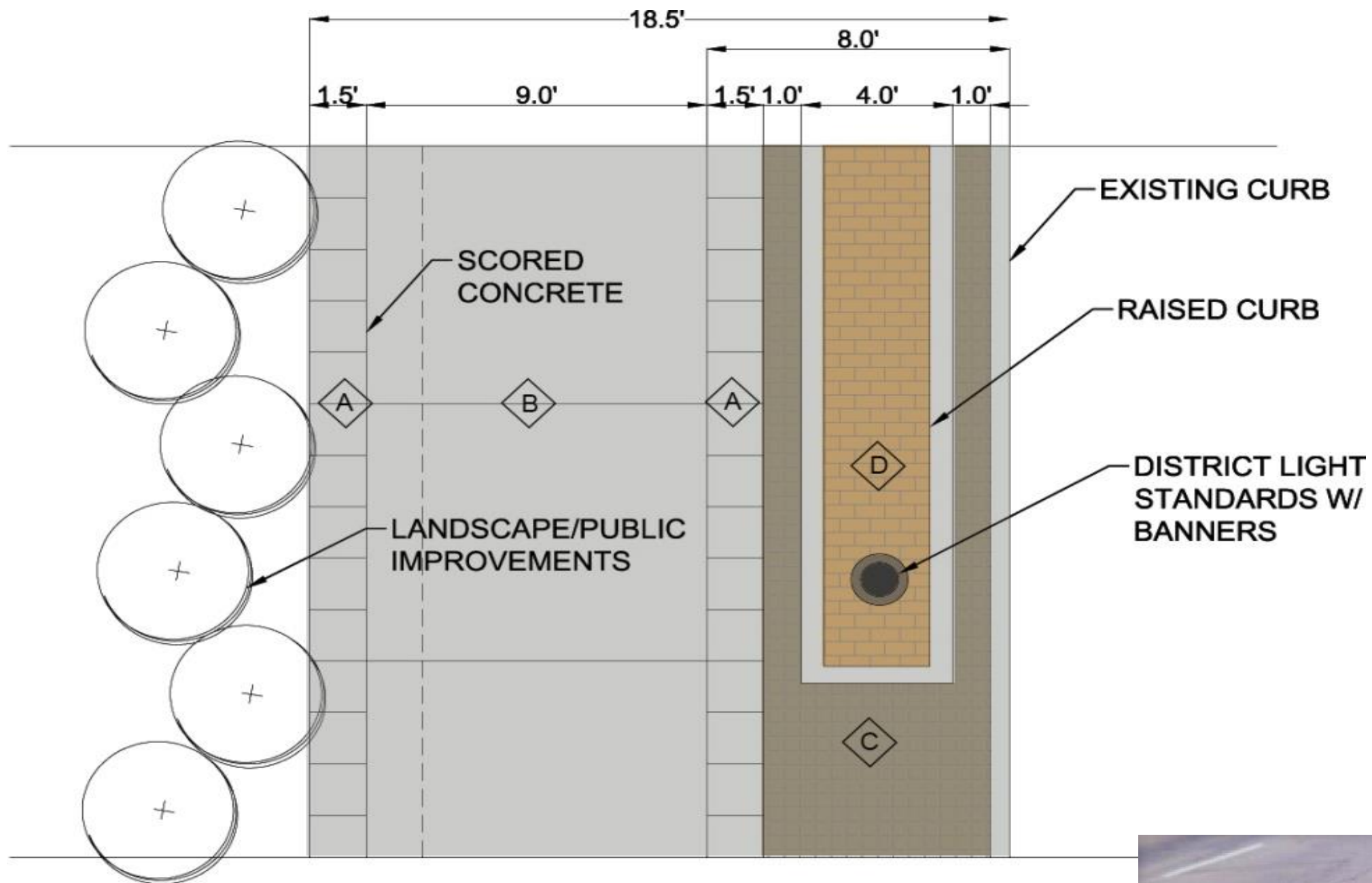

A. CAST-IN-PLACE CONCRETE, 50% GREY, SCORED 18" O.C

C. STAMPED COBBLE STONE CONCRETE, SUPPLIER: PAVESTONE MODEL NO: 401 OR EQUAL COLOR: DARK GREY

B. COLOR STANDARD GRAY-SCORED 10' O.C, CAST-IN-PLACE

D. STAMPED COBBLE STONE CONCRETE SUPPLIER: PAVESTONE



STAMP COBBLE (C & D Pavers)

MATERIALS



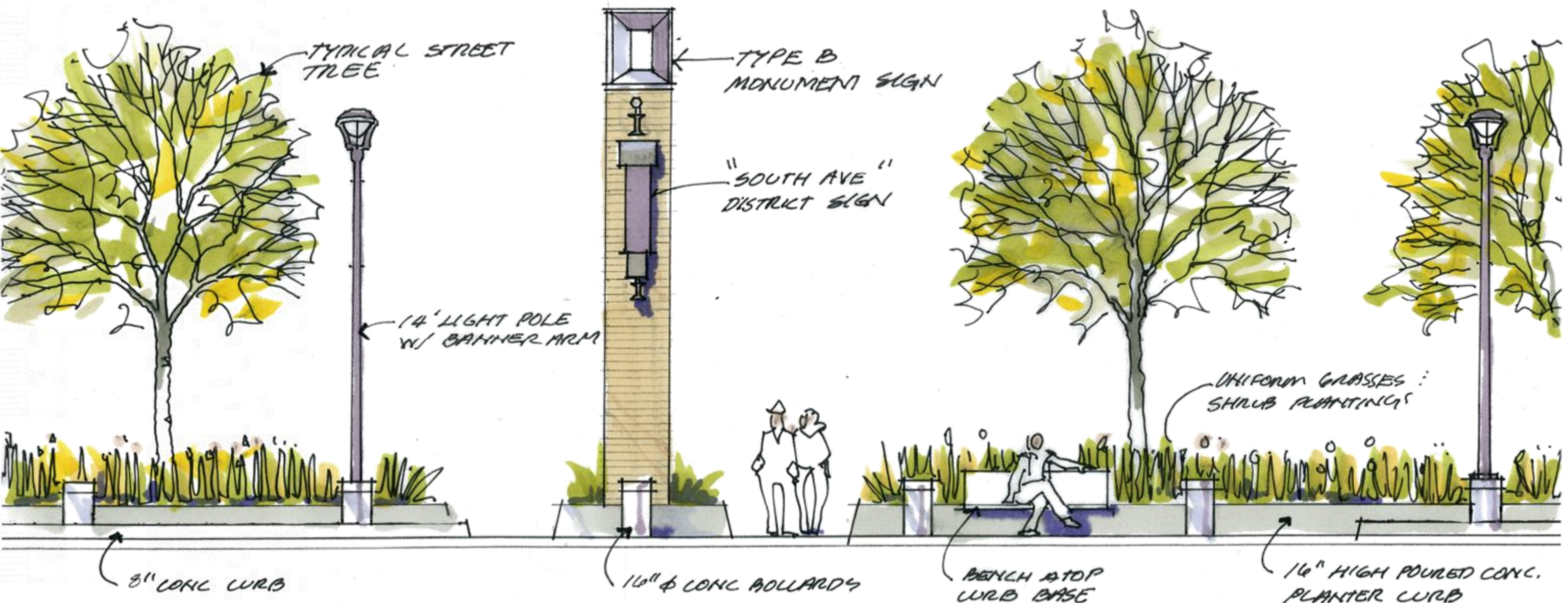

MATERIALS

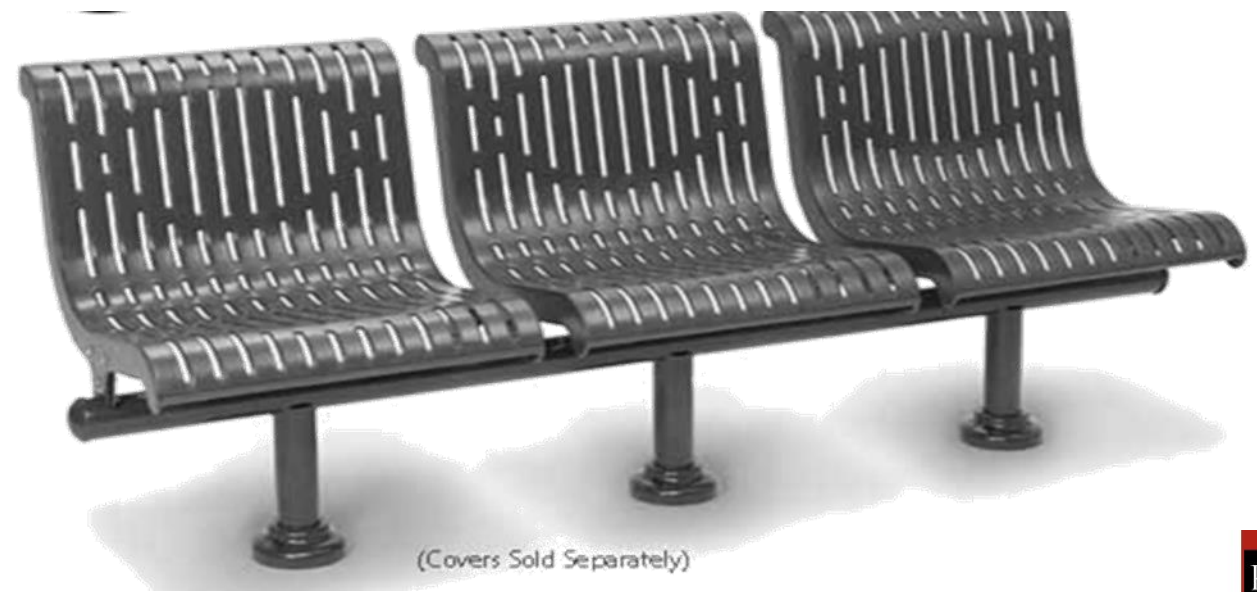
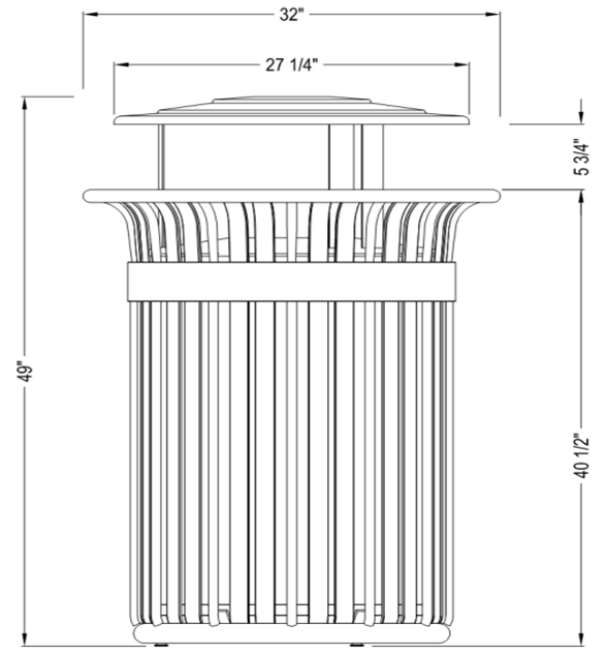

THOMAS THOMAS



PROPOSED STREETScape



THOMAS THOMAS

Equity Group LLC



PROPOSED STREETScape



THOMAS THOMAS

Equity Group LLC



PROPOSED STREETScape



THOMAS THOMAS

Equity Group LLC

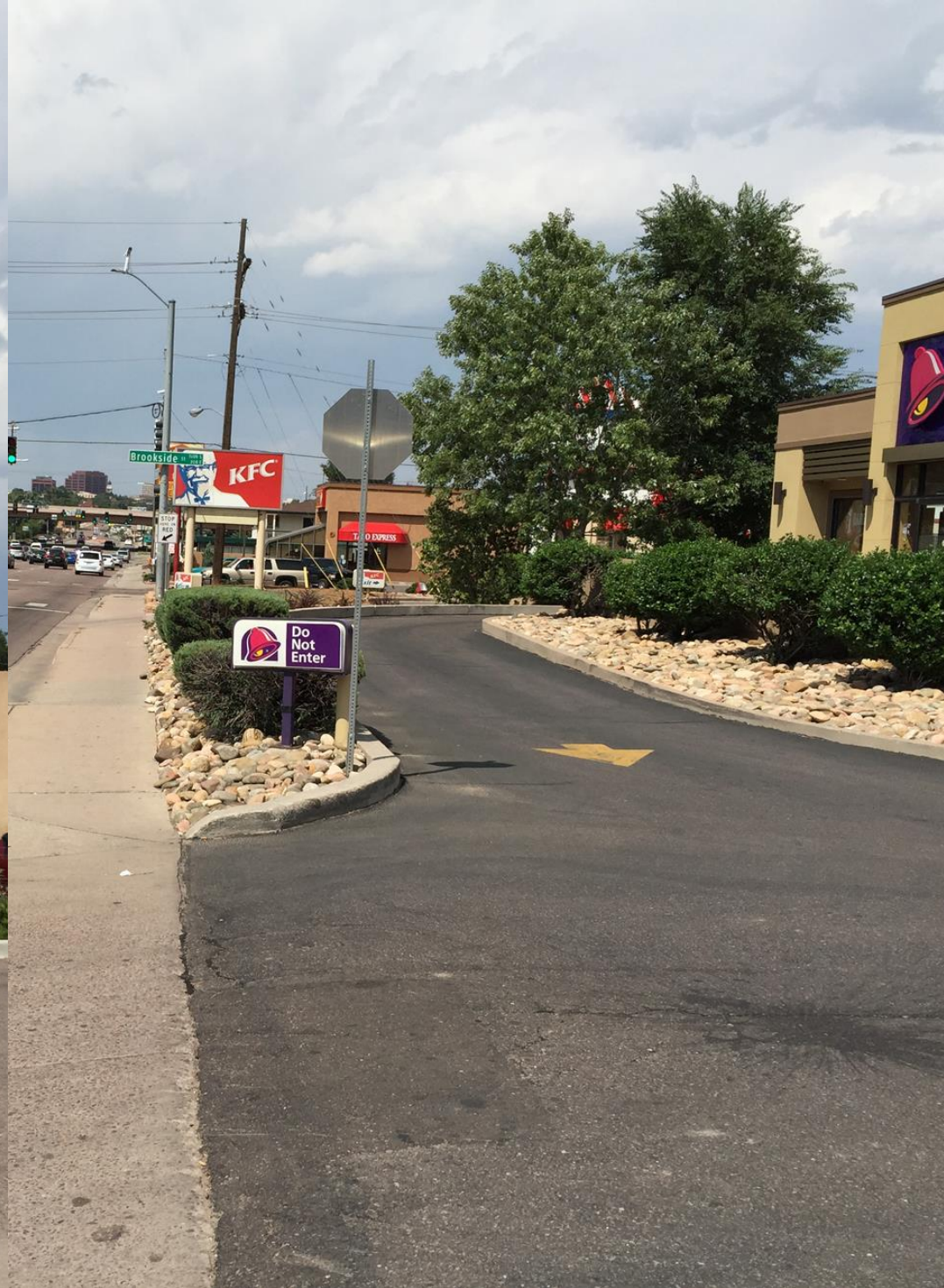

EXISTING STREETScape



THOMAS THOMAS

Equity Group LLC

South Nevada Traffic Plan



 = Existing Light

 = New Light

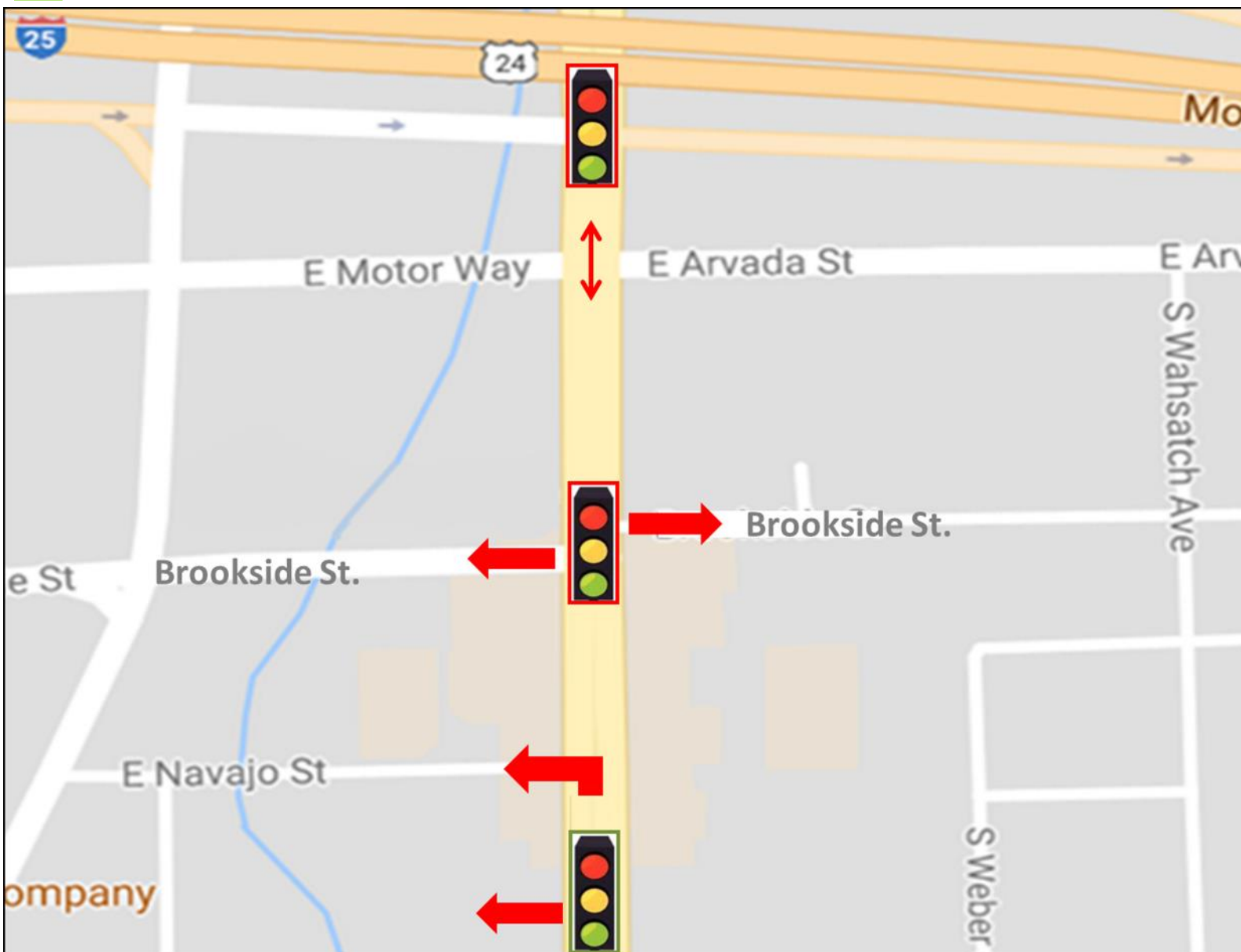

Traffic Signal Changes

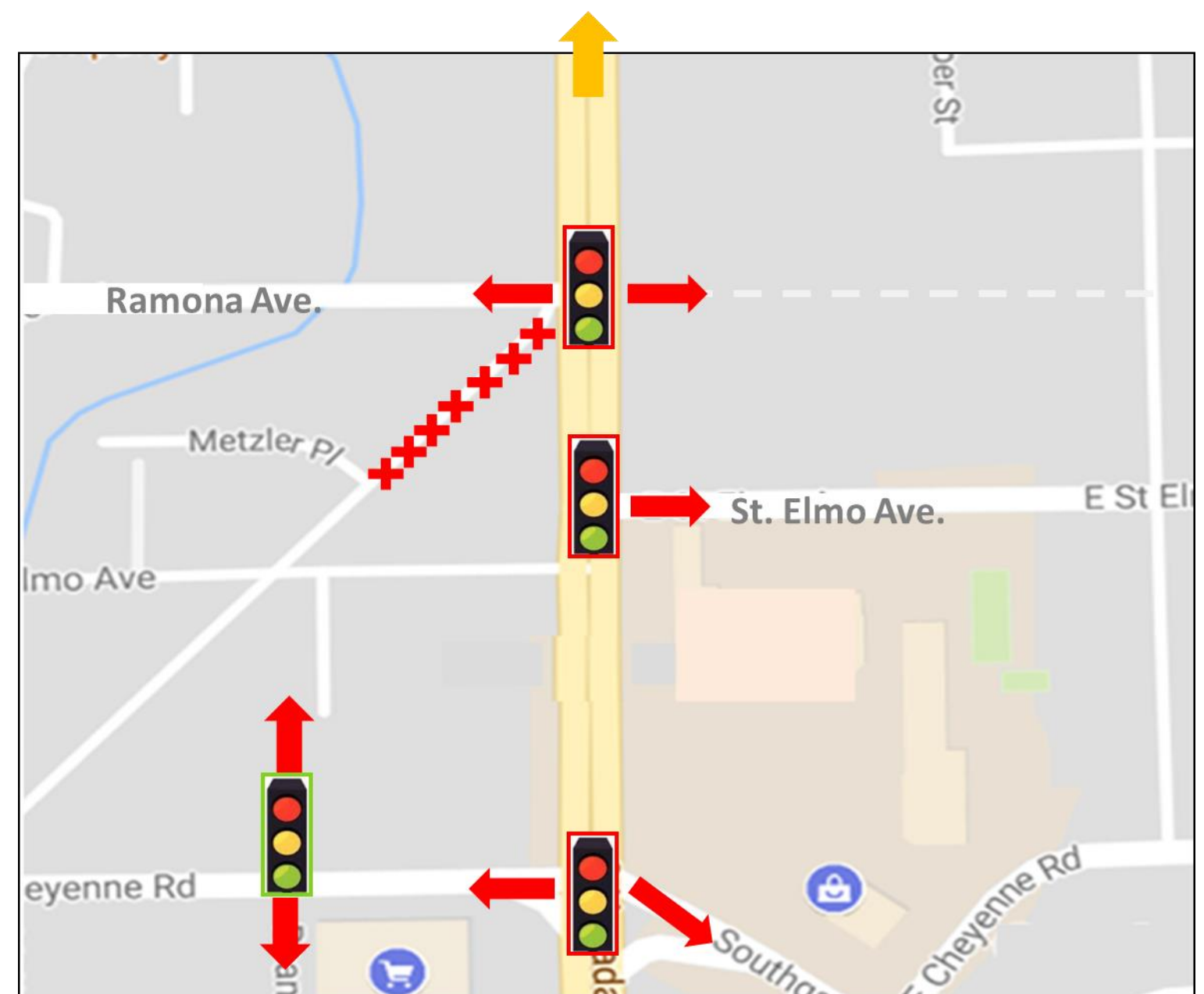

Trail Connections



- City Parks coordinating with developers to create creek trail connecting to Legacy Loop
- Creek as an amenity
- Mobility improvements throughout corridor

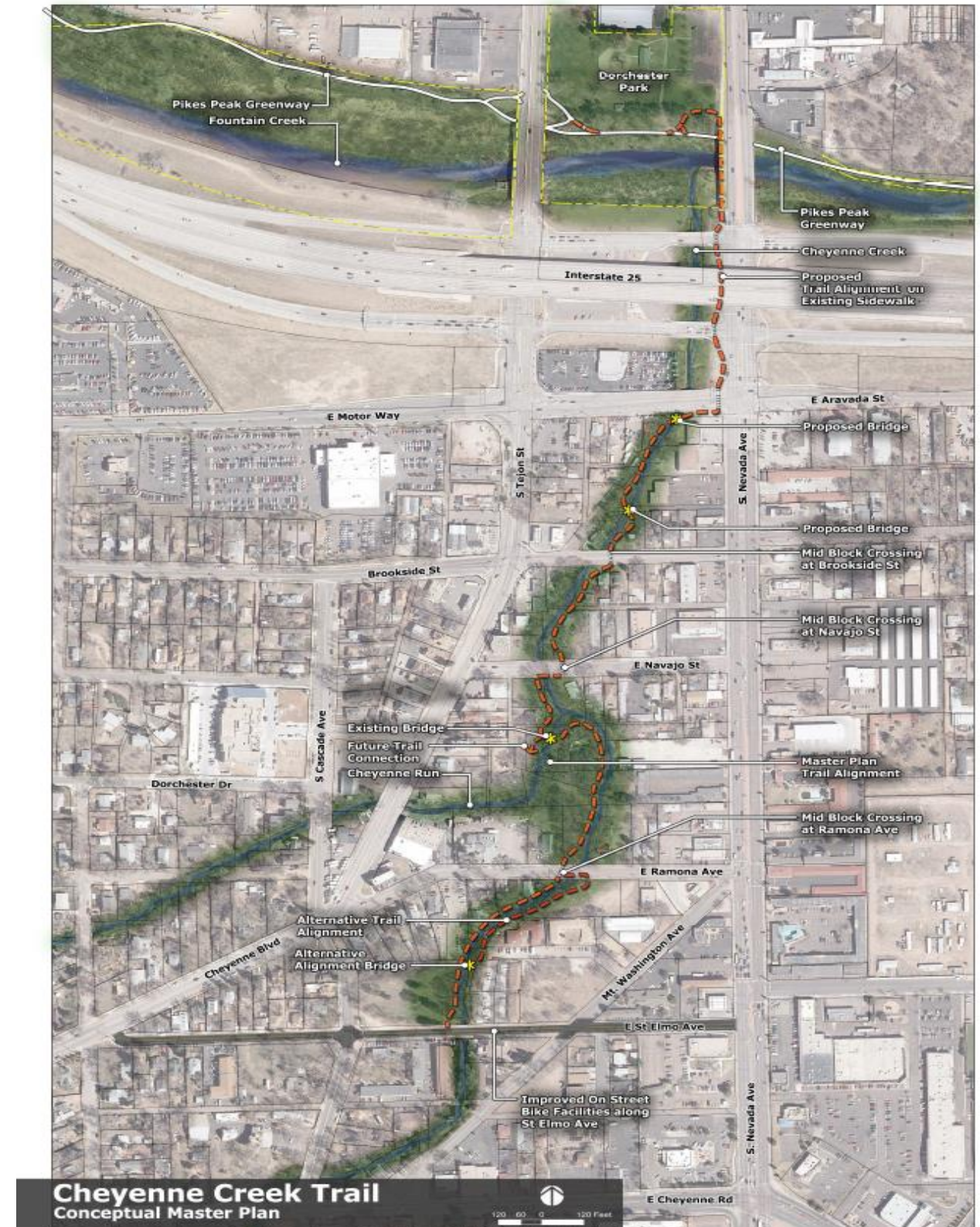

Implementation



- Streetscape design is evaluated at property redevelopment
 - Triggers: rezone, plat, DP/CP
- No obligation to upgrade streetscape under status quo
- Standards used to guide designers and reviewers for consistent level of improvement

Evaluation



- URA and Economic Development Staff support
- Ivywild Master Plan considerations
- Comprehensive Plan Objectives, Policies, and Strategies
 - Infill Chapter: Efforts on S. Nevada are closely aligned with City’s infill priorities
 - Infill Chapter: “enhance the viability of multimodal transportation options including transit use, cycling and walking”

Next Steps



- URA Streetscape Design Approval (Completed)
- Public Meeting 7/14/17 (Completed)
- Planning Commission Meeting 8/17/17 (Completed)
- City Council Meetings For Final Approval
 - September Work Session
 - October Formal

Recommendation



Approval of the South Nevada Urban Renewal District Streetscape Design Standards with new language added regarding relief per Planning Commission direction



QUESTIONS?